

XTL1014

48.5300 MHz
Crystal Unit

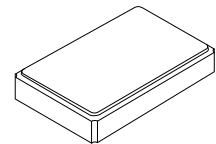

SM2520-4 Case

- **High Reliability Quartz Crystal**
- **Good Frequency Stability over Temperature**
- **Ultra-Miniature 2.5 x 2.0 mm SMD Package**
- **Complies with Directive 2002/95/EC (RoHS)**
- **Moisture Sensitivity Level**

The XTL1014 is a surface mount 2.5 x 2.0 x 0.6 mm crystal unit for use in wireless telecommunications devices, especially where an ultra-miniature package is needed for mobility.

Electrical Characteristics

Characteristic	Sym	Notes	Minimum	Typical	Maximum	Units
Nominal Frequency	f_o			48.5300		MHz
Load Capacitance	C_L			8		pF
Mode of Vibration			Fundamental			
Drive Level				10		uW
Frequency Make Tolerance	f_L		±30 ppm @ 25 °C ±3 °C			ppm
Frequency Stability Over Operating Temperature Range			±30 ppm (referred to the value at 25 °C)			
Resistance	ESR				50	Ω
Static Shunt Capacitance	C_o				2	pF
Storage Temperature Range			-40		+85	°C
Operating Temperature Range			-40		+85	°C
Aging					±1	ppm/yr
Standard Shipping Quantity on 178 mm (7") Reel				3000		units
Lid Symbolization: Y = Year, W = Week				2F <u>YW</u>		

Crystal Equivalent Circuit

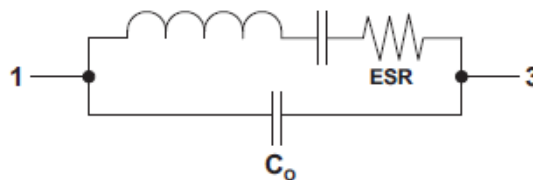

CAUTION: Electrostatic Sensitive Device. Observe precautions for handling.

NOTES:

1. The design, manufacturing process, and specifications of this device are subject to change.
2. US or International patents may apply.
3. RoHS compliant from the first date of manufacture.

SM2520-4 Case

4-Terminal Surface-Mount Case 2.5 x 2.0 mm Nominal Footprint

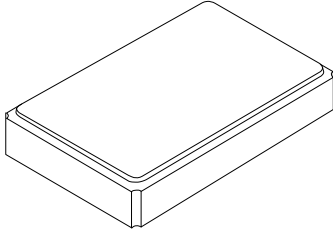

Electrical Connections

Connection	Terminals
Input / Output	1
No Connection	2
Input / Output	3
Metal Cover	4

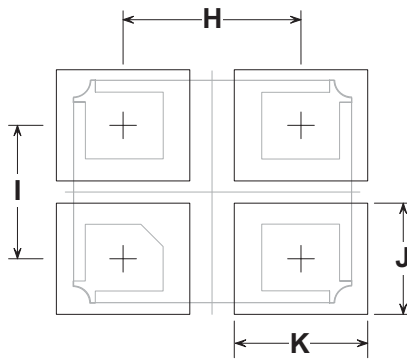

Typical PCB Land Footprint
(Top View)

Case and PCB Land Dimensions

Dimensions	Millimeters			Inches		
	Min	Nom	Max	Min	Nom	Max
A	2.40	2.50	2.60	0.095	0.098	0.102
B	1.90	2.00	2.10	0.075	0.078	0.083
C			0.60			0.024
D		1.60			0.063	
E		1.20			0.047	
F		0.60			0.024	
G		0.70			0.028	
H		1.60			0.063	
I		1.20			0.047	
J		1.00			0.039	
K		1.20			0.047	

Case Outline Drawing

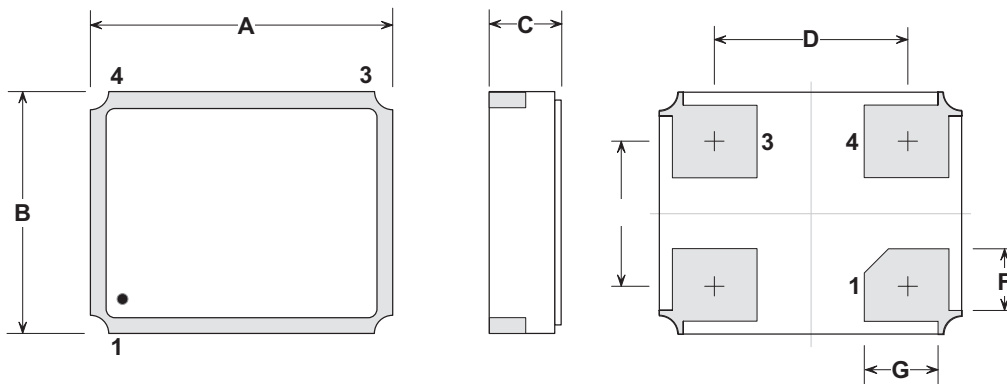

Case Orientation

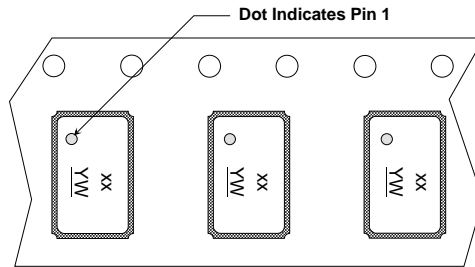

Reel Dimensions

Tape and Reel Standard per ANSI/EIA-481

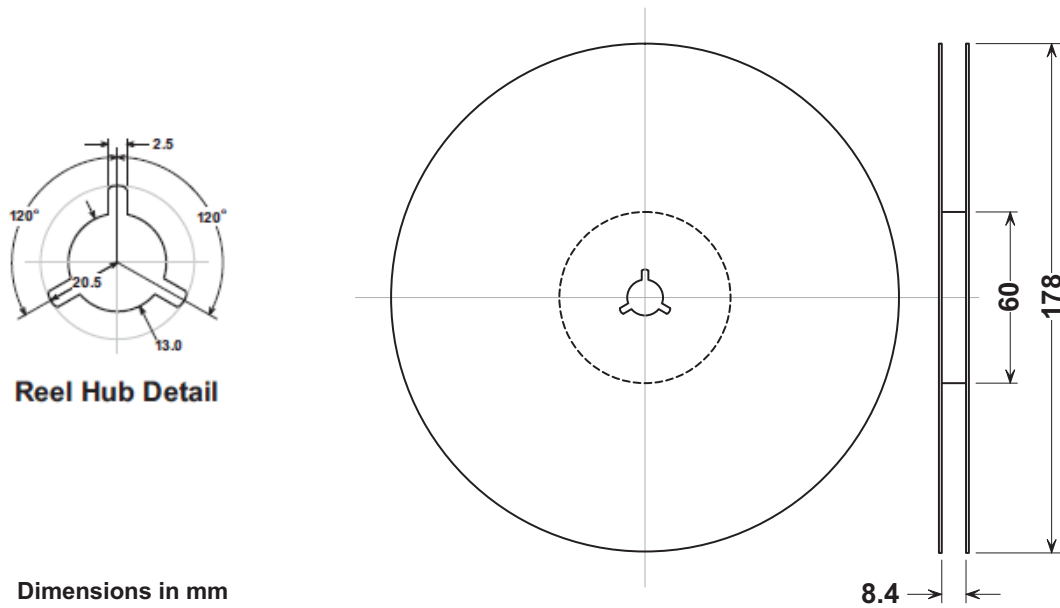

Tape Dimensions

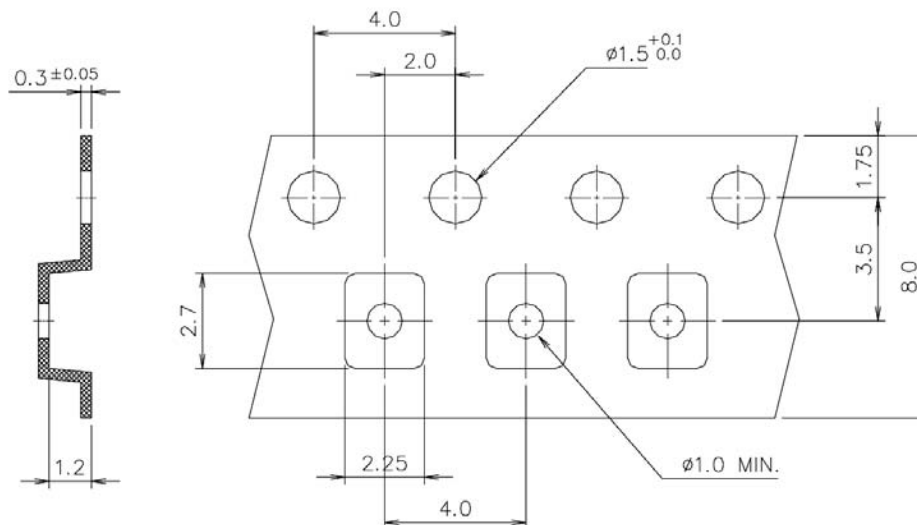

Recommended Reflow Profile

1. Preheating shall be fixed at 150~180°C for 60~90 seconds.
2. Ascending time to preheating temperature 150°C shall be 30 seconds min.
3. Heating shall be fixed at 220°C for 50~80 seconds and at 260°C +0/-5°C peak (10 seconds).
4. Time: 5 times maximum.

