



RFM Integrated Device, Inc.

PRODUCT SPECIFICATION

Part Number:

SF2604NA

Filter, Duplexer, LTE
Band 28B, 733/788MHz,
BW 30.0MHz, IL 3.6dB

SMD 1.8 x 1.4 mm

MAXIMUM RATING:

1. Input power : 29dBm (Ta=+50deg C,50000h,CW)
2. Maximum DC Voltage: +/-5 V
3. Operating temperature range: -40 °C to +85 °C
4. Storage temperature range: -55 °C to +125 °C
5. Moisture Sensitivity Level: Level 1 (MSL 1)
6. ESD 100V(MM) 200V(HBM)
7. AEC-Q200 Qualified

**ELECTRICAL CHARACTERISTICS:**

- Terminating impedance(Tx Port): 50//12nH Ω (Single-ended)
 Terminating impedance(Rx Port): 50 Ω (Single-ended)
 Terminating impedance(Ant Port): 50//8.2nH Ω (Single-ended)

Tx to ANT($f_{T0}=733$ MHz)

Parameters		Description	Unit	Minimum	Typical	Maximum	Note
Insertion Loss		718 ~ 748 MHz	dB(*1)	-	1.8	3.6	
		718.25 ~ 747.75 MHz			1.7	3.2	
Ripple		718 ~ 748 MHz	dB	-	1.1	2.9	
VSWR	Tx	718 ~ 748 MHz	-	-	1.9	2.3	
	ANT		-	-	1.8	2.2	
Attenuation:							
10 ~ 698 MHz			dB	32	36	-	-
698 ~ 710 MHz			dB	15	26	-	-
758 ~ 773 MHz			dB	10	39	-	-
773 ~ 803 MHz			dB	50	55	-	Rx
1436 ~ 1496 MHz			dB	25	29	-	2fo
1565 ~ 1606 MHz			dB	22	25		GPS
2154 ~ 2244 MHz			dB	28	32		3fo
2400 ~ 2500 MHz			dB	30	38		ISM

ANT to Rx($f_{T0}=788$ MHz)

Parameters		Description	Unit	Minimum	Typical	Maximum	Note
Insertion Loss	773 ~ 803 MHz		dB(*1)	-	1.9	3.6	
	773.25 ~ 802.75 MHz				1.8	3.2	
Ripple		773 ~ 803 MHz	dB	-	0.8	2.9	
VSWR	ANT	773 ~ 803 MHz	-	-	1.8	2.5	
	Rx		-	-	1.7	2.5	
Attenuation:							
718 ~ 748 MHz			dB	50	63	-	Tx-
2400 ~ 2500 MHz			dB	30	73	-	ISM

Tx to Rx

Isolation	718 ~ 748 MHz		dB	57	63	-	Tx
	773 ~ 803 MHz		dB	53	60	-	Rx

(*1) De-embedded test fixture.

Frequency Characteristics:

Tx to Ant

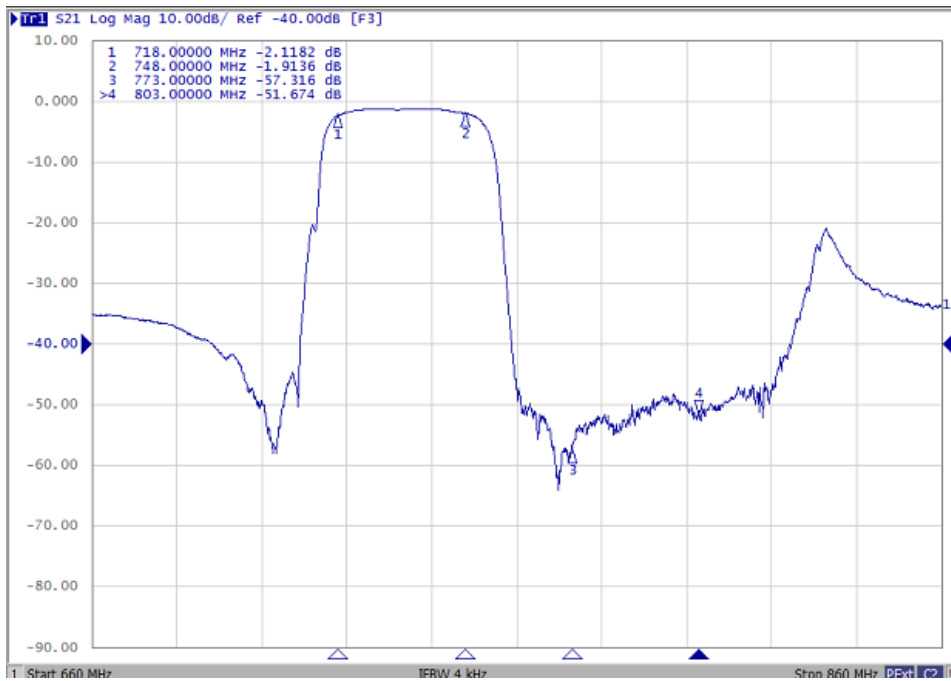

Ant to Rx

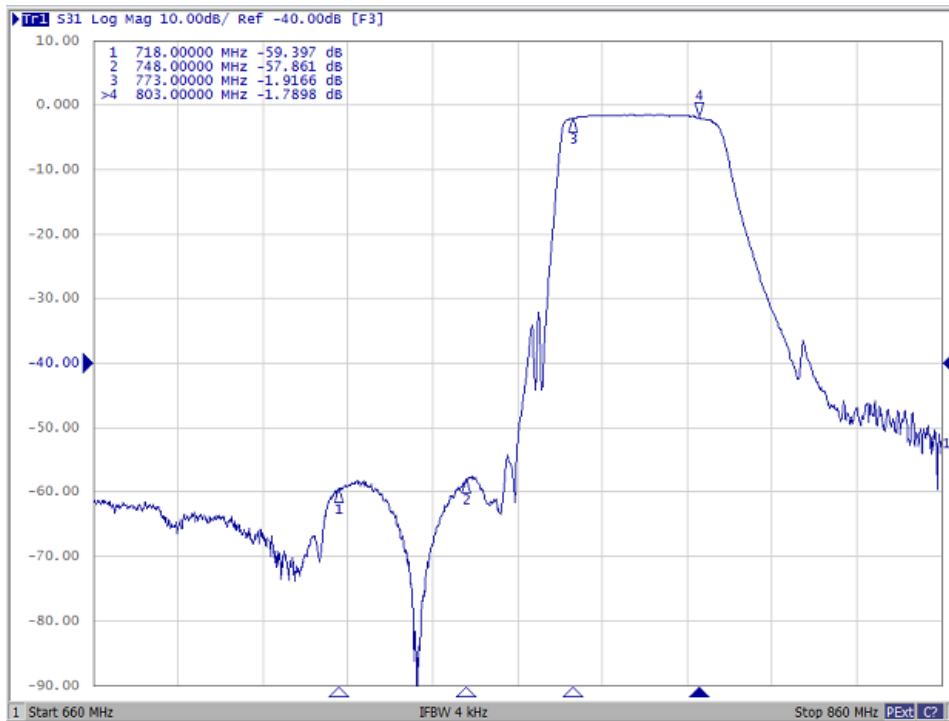

Ripple Deviation

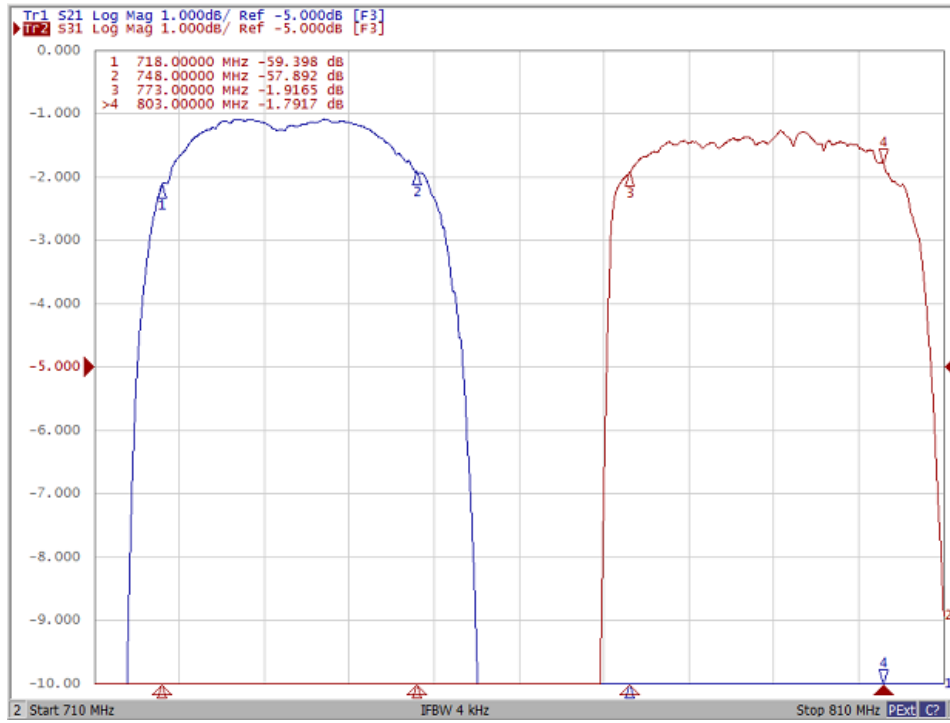

Isolation

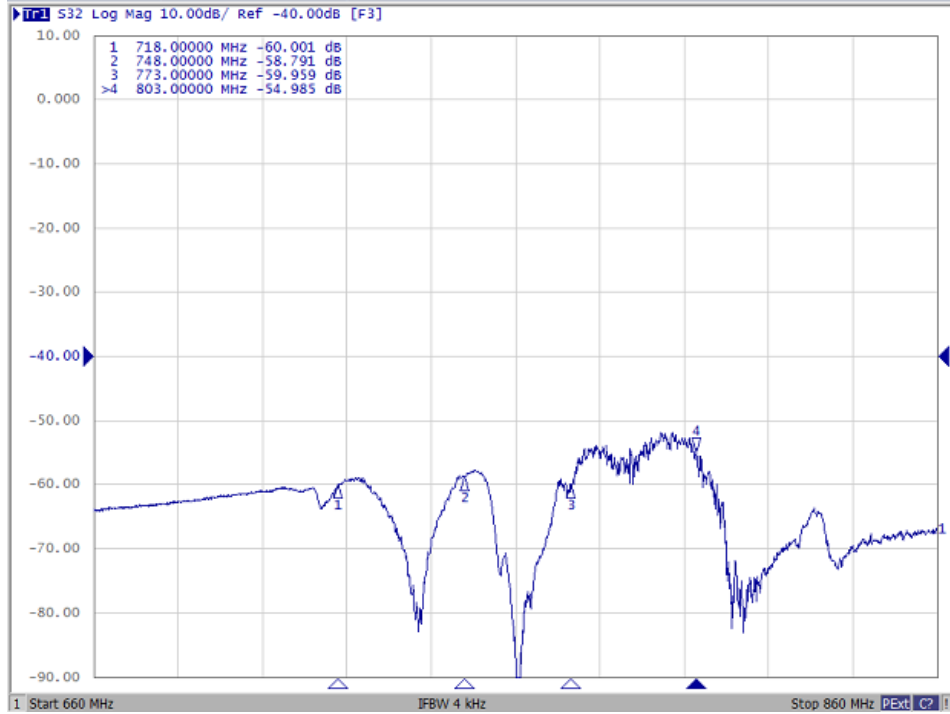

VSWR (Tx Port)

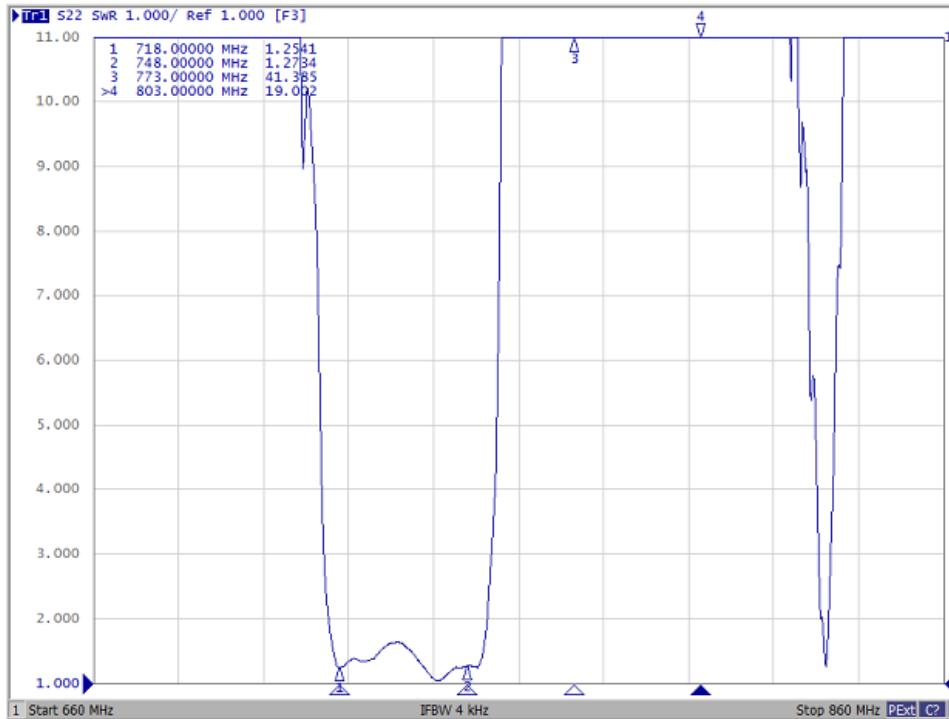

Smith Chart (Tx Port)

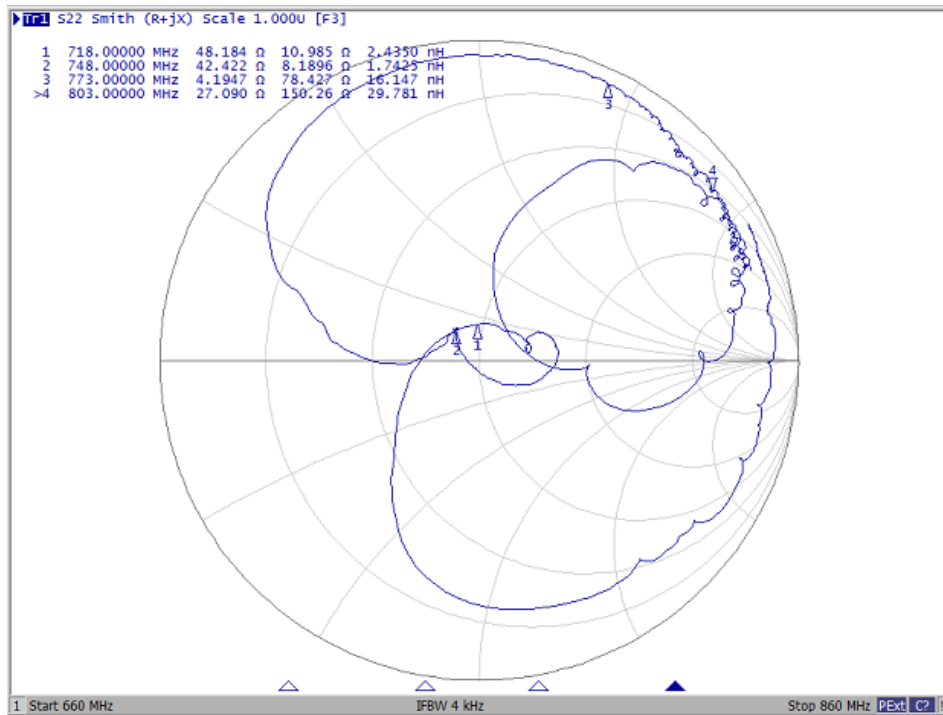

VSWR (Rx Port)

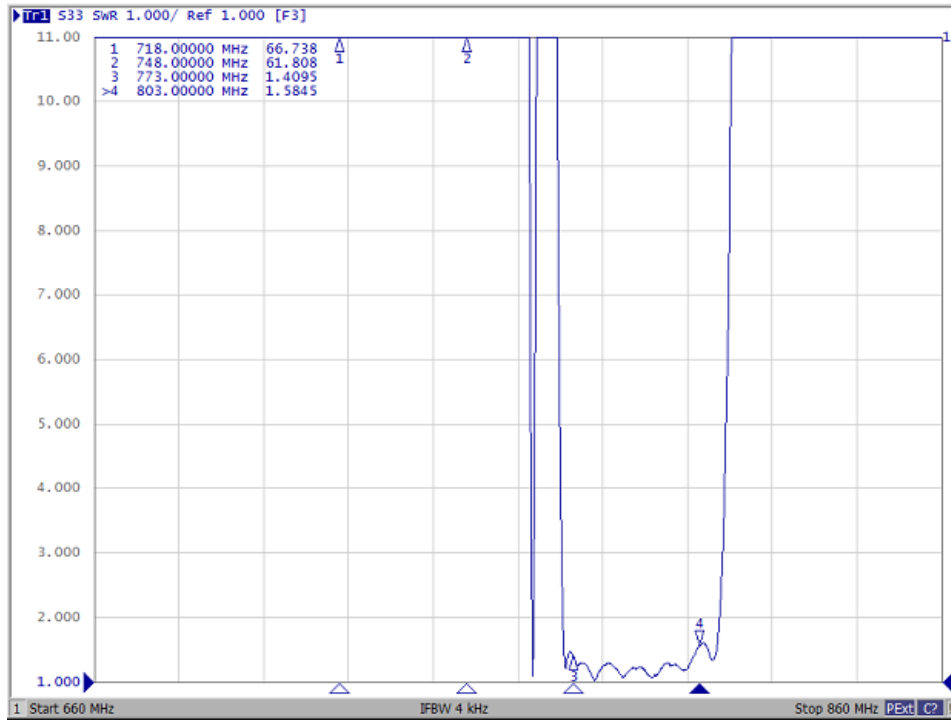

Smith Chart (Rx Port)

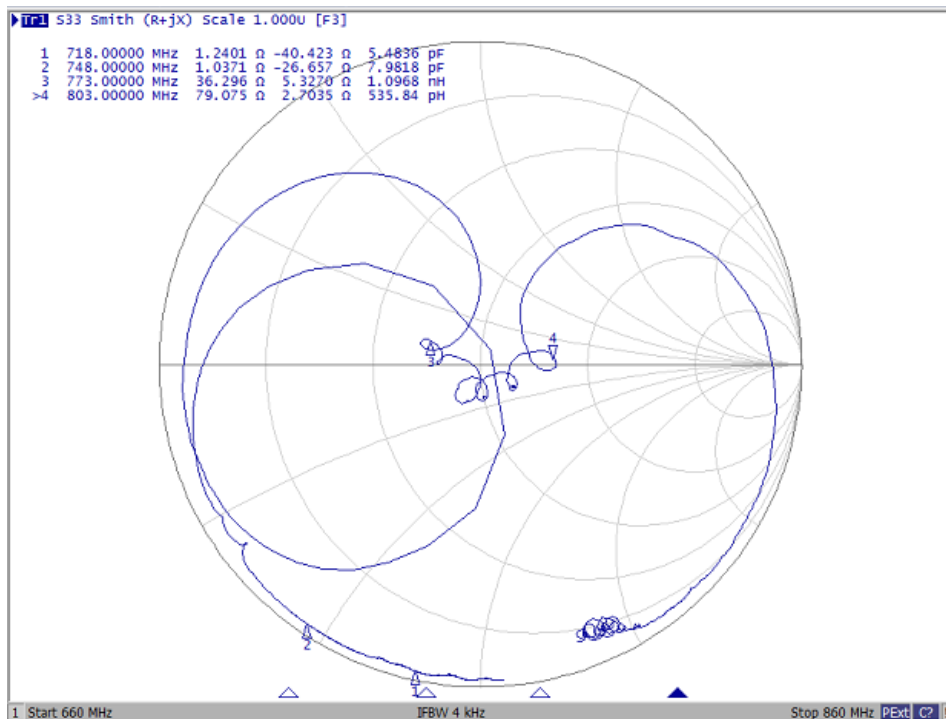

VSWR (ANT Port)

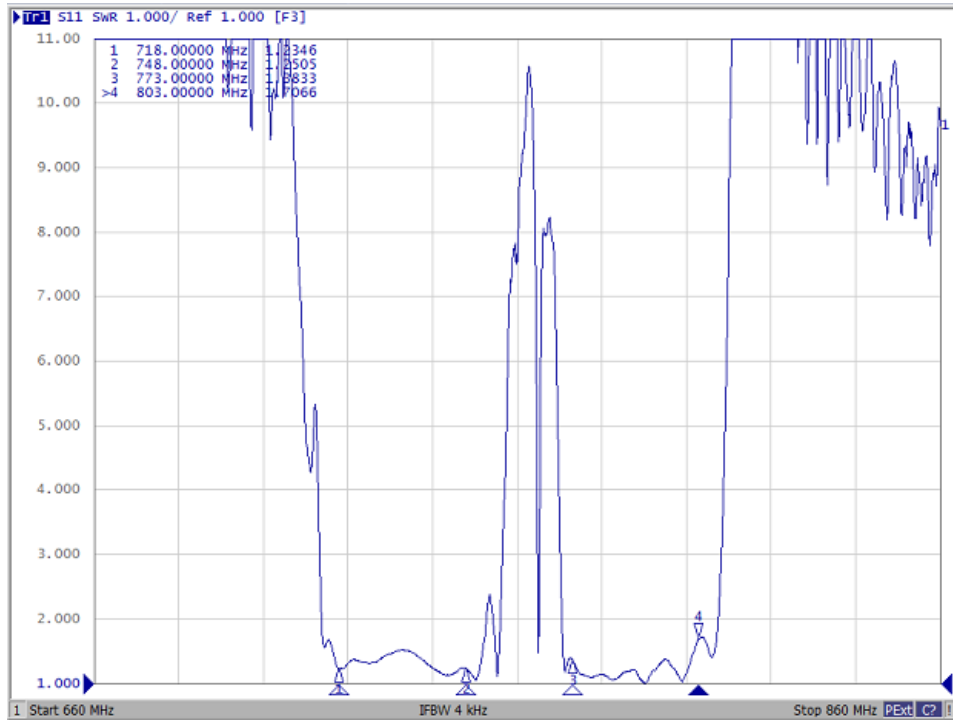

Smith Chart (ANT Port)

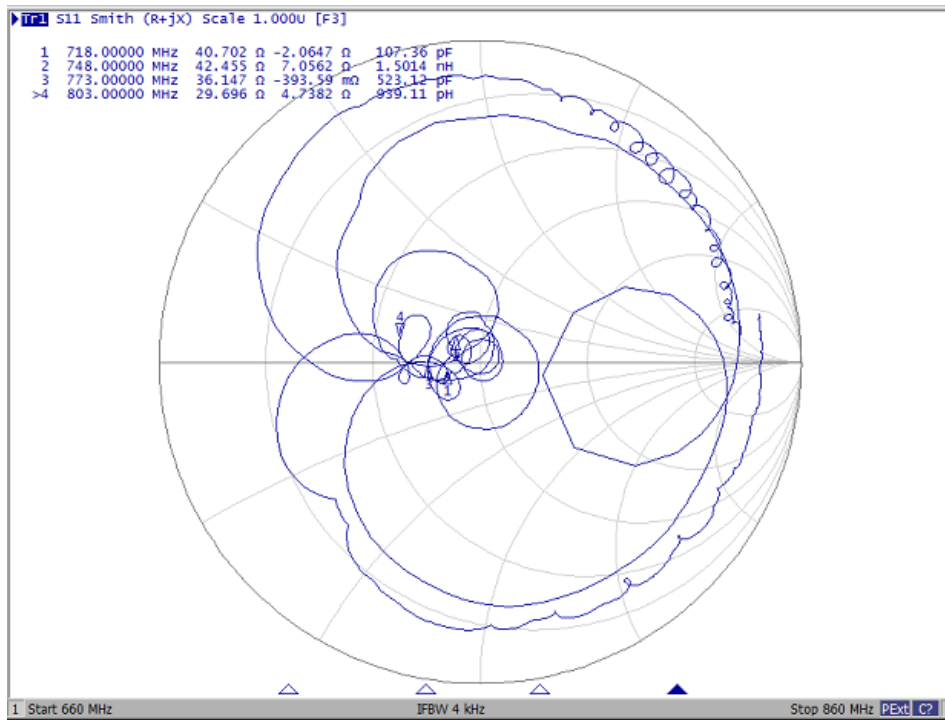

Tx to Ant (Wide Span)

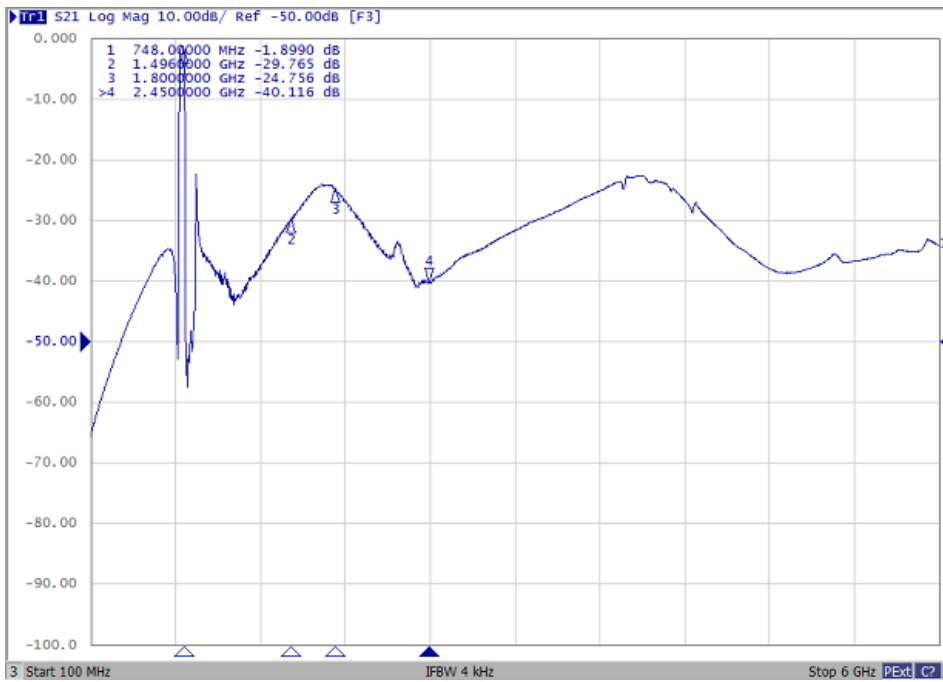

Ant to Rx (Wide Span)

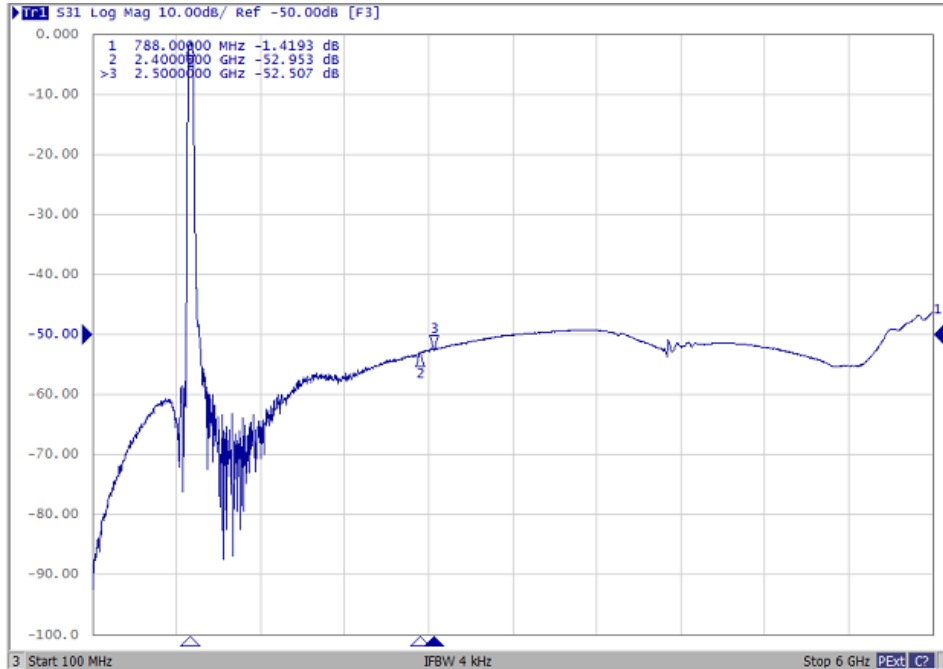

Evaluation Circuit

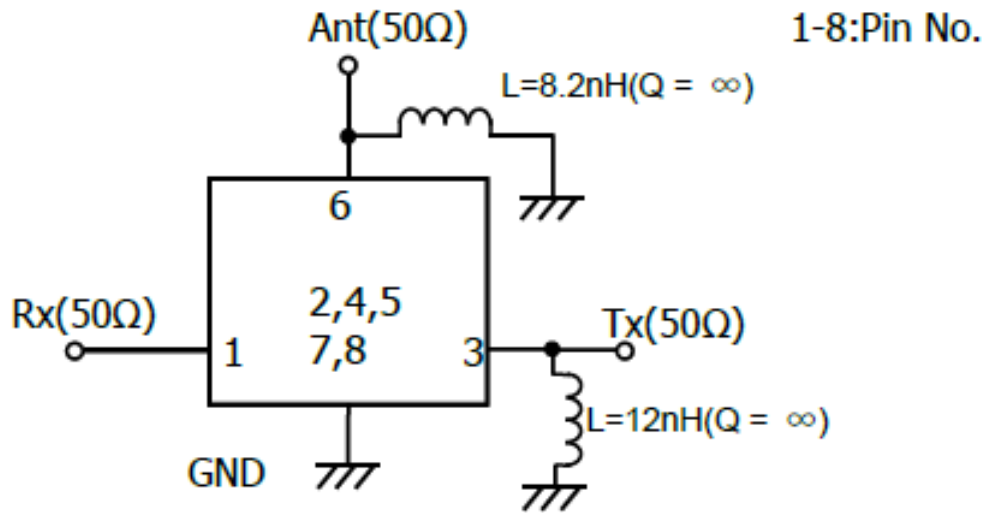

FOOTPRINT:

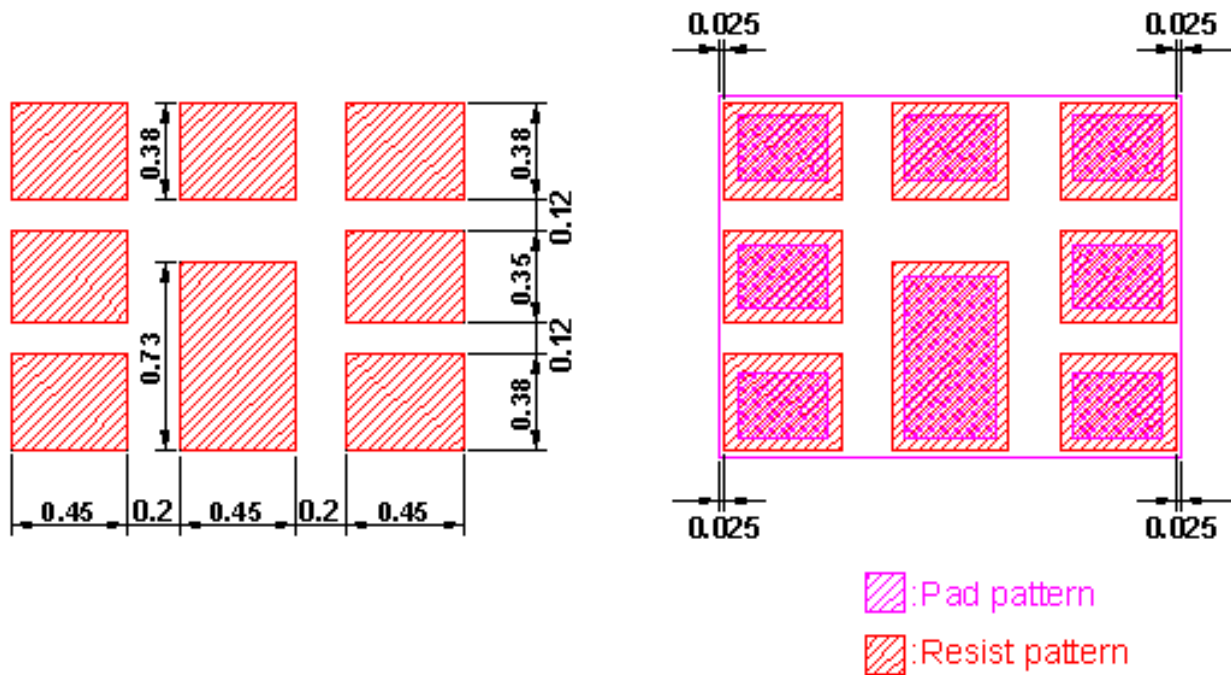

OUTLINE DRAWING:

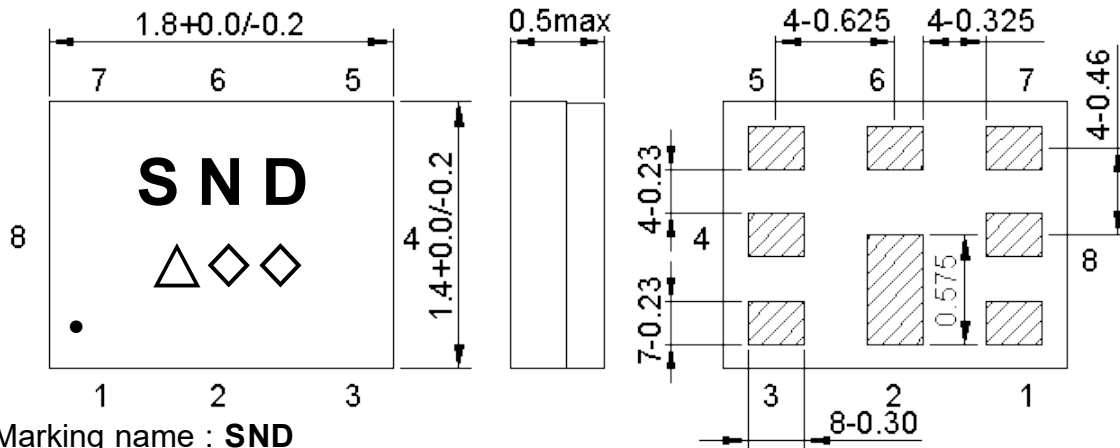

Marking name : **SND**

△: Date code(2016 May → s ,....., 2019 Dec→m.)

◇◇: Lot Code.

Date Code: Follow below table. (4-year cycle)

Year	Jan	Feb	Mar	Apr	May	Jun	Jul	Aug	Sep	Oct	Nov	Dec
2019 / 2023	a	b	c	d	e	f	g	h	j	k	l	m
2020 / 2024	n	p	q	r	s	t	u	v	w	x	y	z
2021 / 2025	A	B	C	D	E	F	G	H	J	K	L	M
2022 / 2026	N	P	Q	R	S	T	U	V	W	X	Y	Z

Pin assignment

Pin No.	Pin name	Description
1	Rx	Receiver
2	GND	Ground
3	Tx	Transmitter
4	GND	Ground
5	GND	Ground
6	Ant	Antenna
7	GND	Ground
8	GND	Ground

Figure 1. Dimensions and Pin assignment

**PACKING:
REEL DIMENSION**

Reel Count:
7" = 3000
13" = 10,000

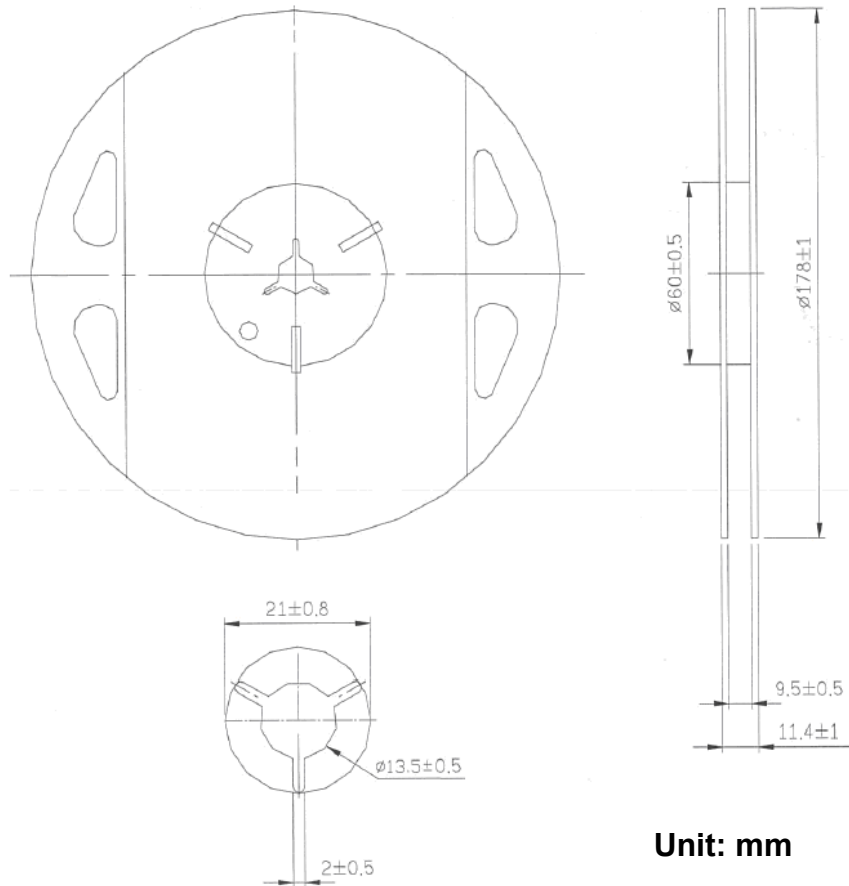

Unit: mm

TAPE DIMENSION

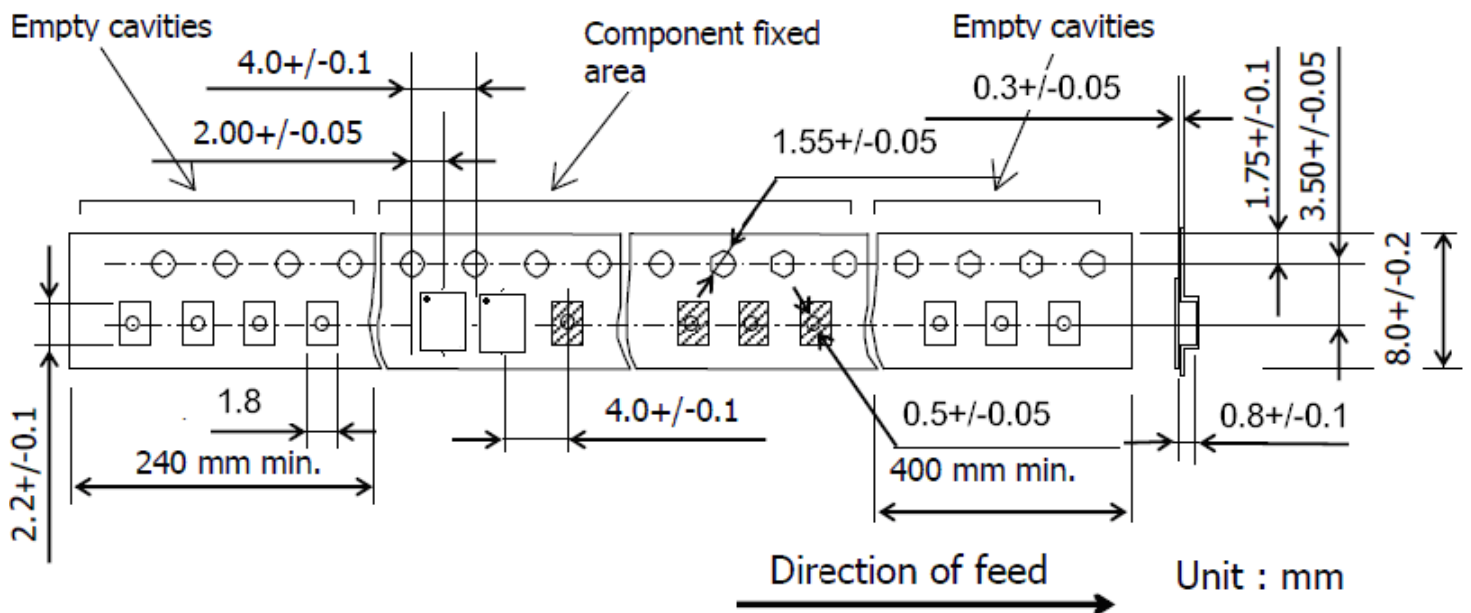

Unit : mm

RECOMMENDED REFLOW PROFILE:

1. Preheating shall be fixed at 150~180°C for 60~90 seconds.
2. Ascending time to preheating temperature 150°C shall be 30 seconds min.
3. Heating shall be fixed at 220°C for 50~80 seconds and at 245~260°C peak (min. 10sec).
4. Time : 2 times.

