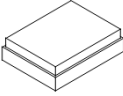

- **Complies with Directive per ANSI/EIA-481**
 - **AEC-Q200 Qualified**
 - **Use for LTE Band 8**
- Maximum Rating**

1. Operating temperature range: -40 °C to +85 °C
2. Storage temperature range: -40 °C to +85 °C
3. Input power : 29dBm (Ta=+50°C,10000h,WCDMA modulation)
4. Maximum DC Voltage: +/-3 V
5. Moisture Sensitivity Level: 1
6. ESD 50V(MM) 100V(HBM)

SF2538NA
897.5/942.5 MHz SAW Duplexer
 SM1814-8

Electrical Characteristics

Terminating impedance (Tx Port): 50//33nH Ω (Single-ended) Terminating impedance (Rx Port): 50 Ω (Single-ended) Terminating impedance (Ant Port): 50//8.2nH Ω (Single-ended)

Tx to ANT (f_{T0}=897.5 MHz)

Parameters Description		Unit	Min	Typ	Max	Remarks
Insertion Loss	882.4~912.6MHz	dB(*1)	-	1.7	2.7(*2)	
	880.24~914.76MHz	dB(*1)		2.1	3.6	
Amplitude ripple	880~915MHz	dB	-	1.3	3.1	
VSWR	ANT		-	-	1.6	2.4
	Tx		-	-	1.5	2.4
Attenuation:						
927.4~957.6 MHz		dB	48(*2)	60	-	
1573.3~1605.9 MHz		dB	40	46	-	
1760~1830 MHz		dB	40	47	-	
2640~2745 MHz		dB	28	35	-	

ANT to Rx (f_{T0}=942.5 MHz)

Parameters Description		Unit	Min	Typ	Max	Remarks
Insertion Loss	927.4~957.6 MHz	dB(*1)	-	1.8	2.7(*2)	
	925~960 MHz	dB(*1)		2.0	3.3	
Amplitude ripple	925~960 MHz	dB	-	0.9	2.5	
VSWR	ANT	-		1.8	2.5	
	Rx	-		1.7	2.4	
Attenuation:						
882.4~912.6 MHz		dB	50(*2)	57	-	
2400~2500 MHz		dB	40	51	-	

Tx to Rx

Isolation	882.4~912.6MHz	dB	55(*2)	58	-	
	927.4~957.6 MHz	dB	55(*2)	59	-	0 to +85 °C
		dB	53(*2)			-10 to 0 °C
		dB	50(*2)			-20 to -10 °C

(*1) Specification of insertion loss excludes loss that comes from the test board.

(*2) Integrated over +/-1.92MHz around the WCDMA channel center frequency

Frequency Characteristics

Tx to Ant

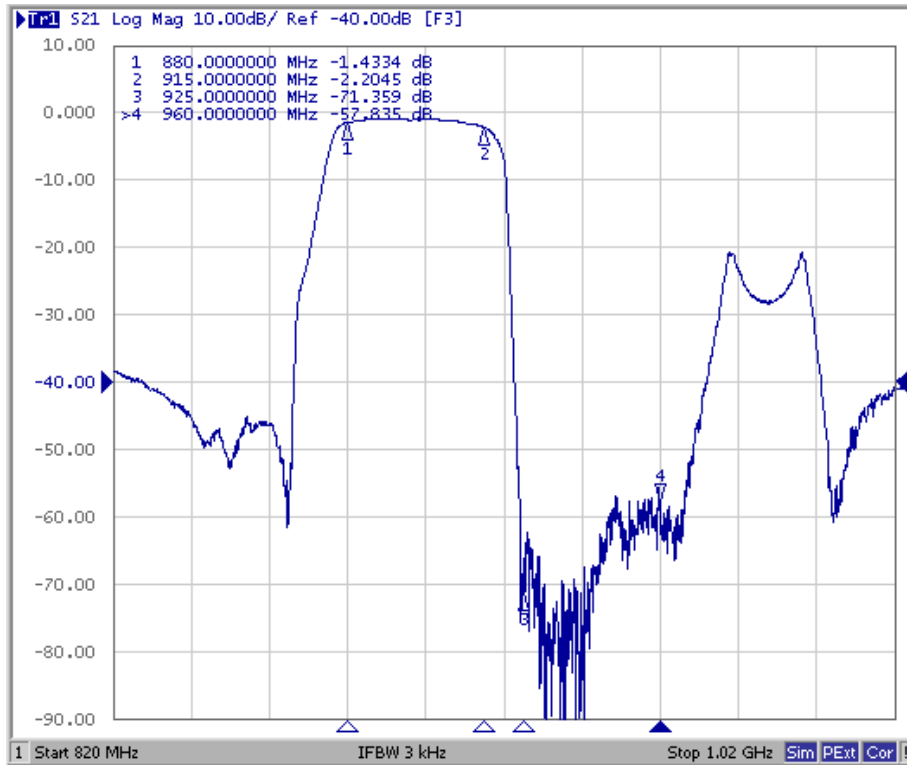

Ant to Rx

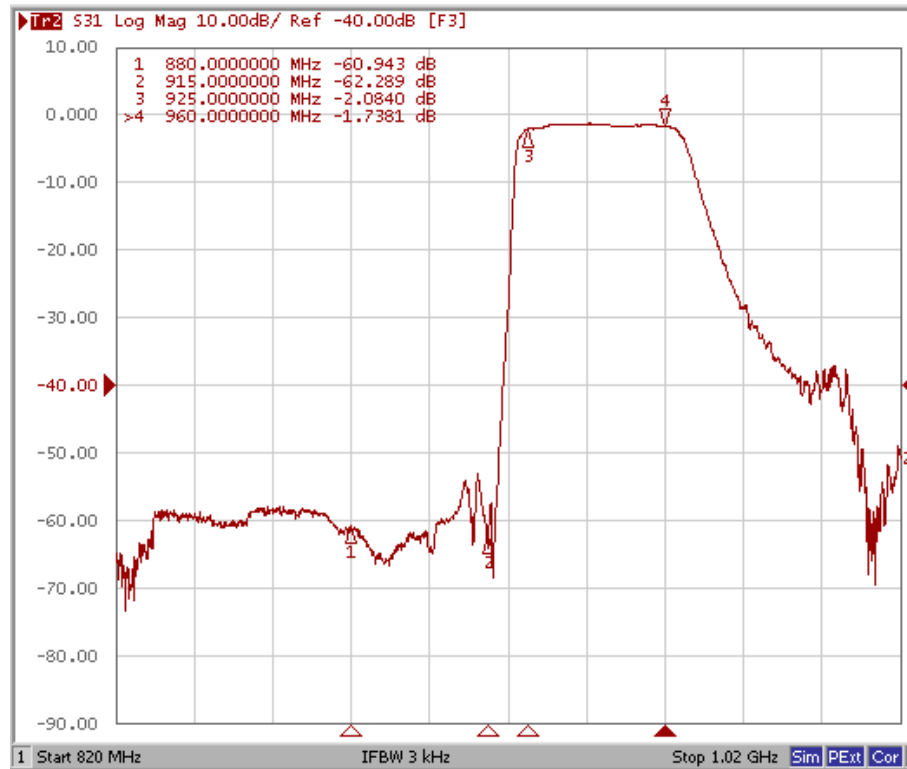

These data **exclude** loss that comes from the test board.

Tx to Ant ,Ant to Rx

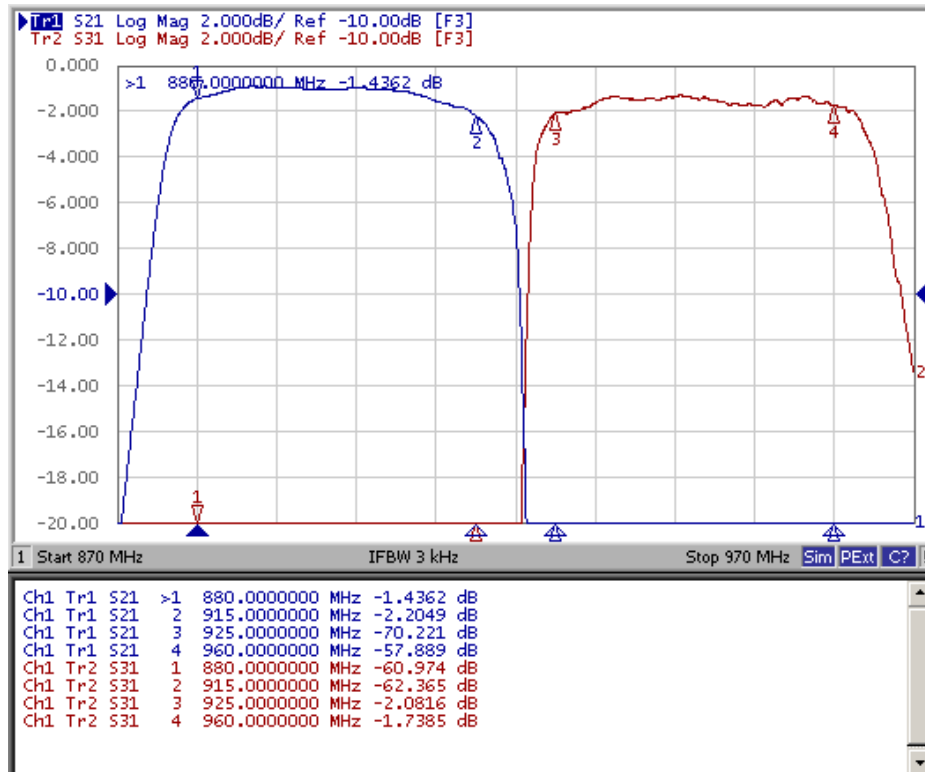

Tx to Rx Isolation

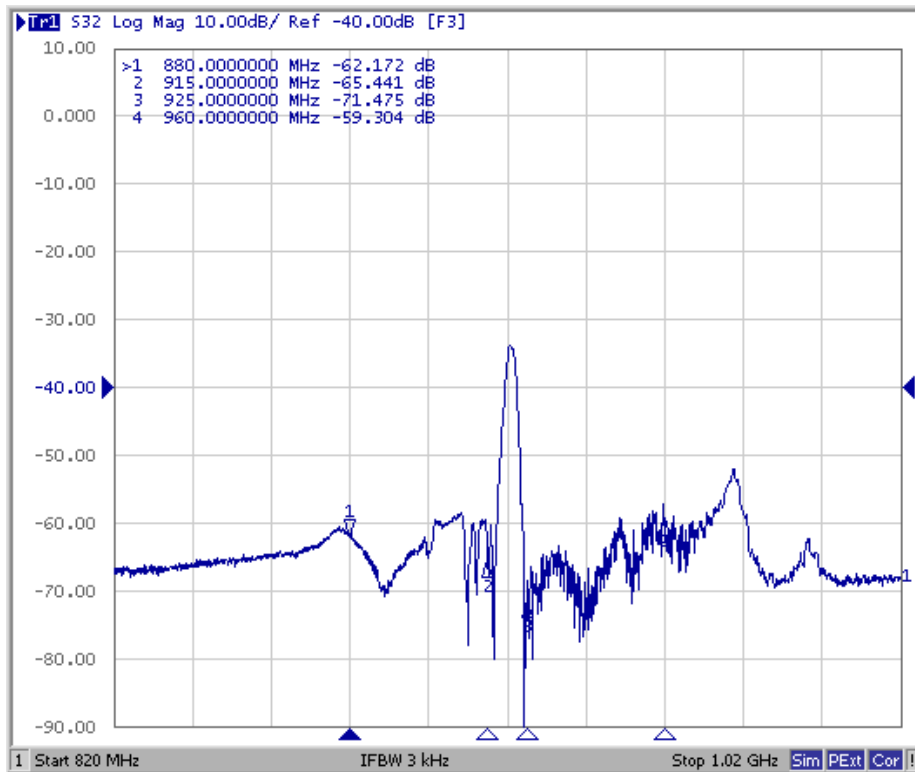

These data **exclude** loss that comes from the test board

Tx Port

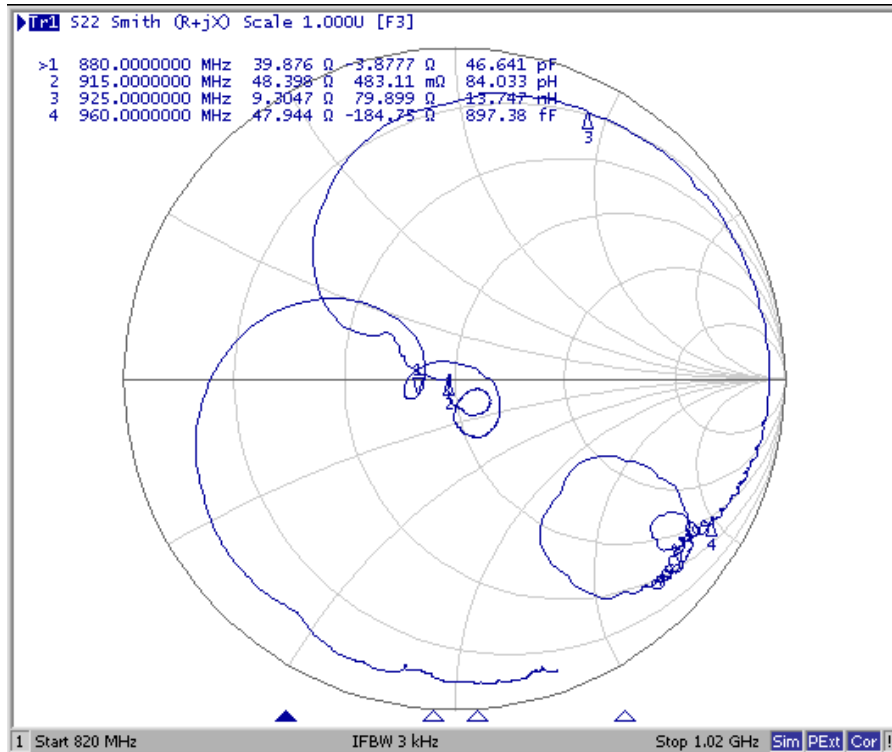
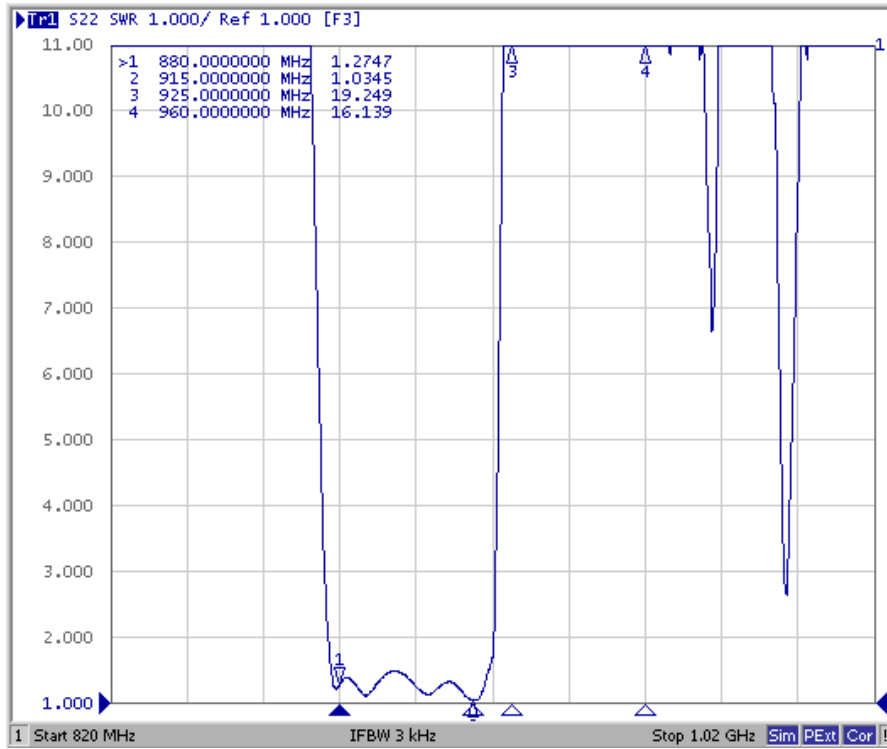

Rx Port

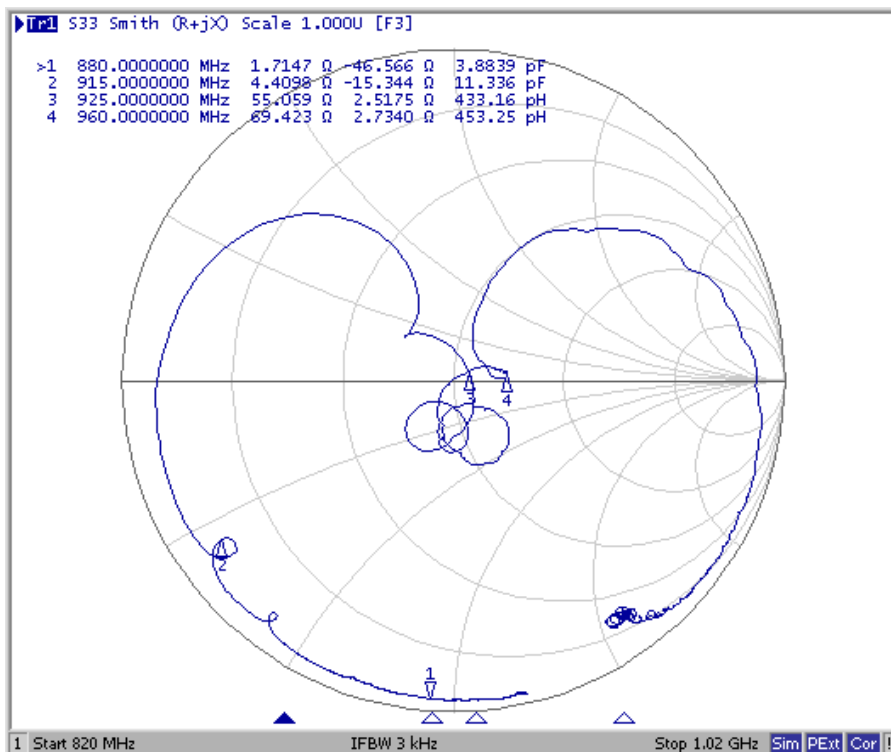
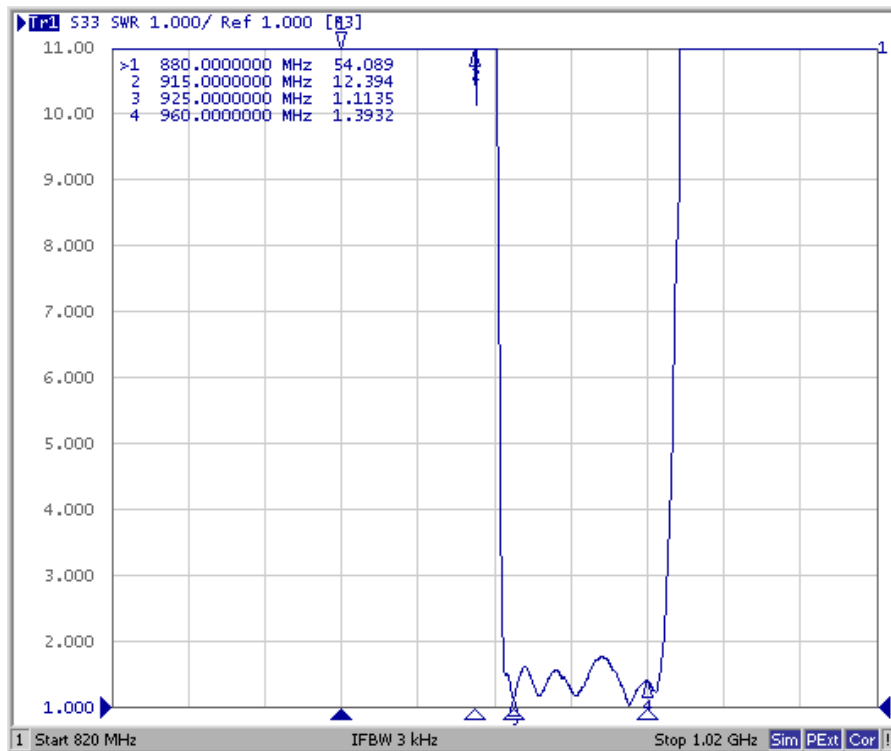

Ant Port

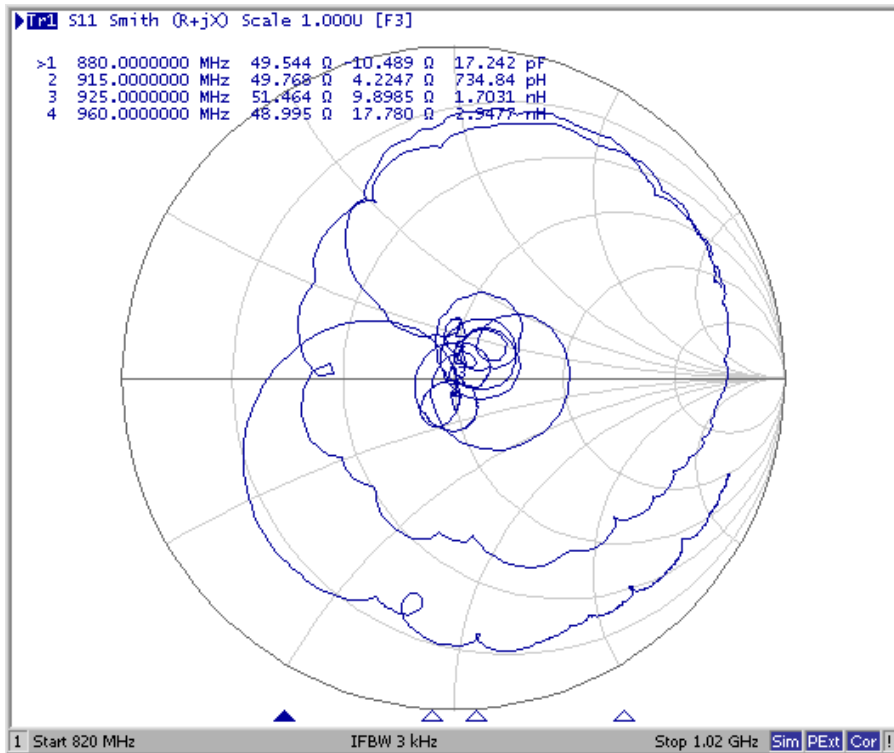
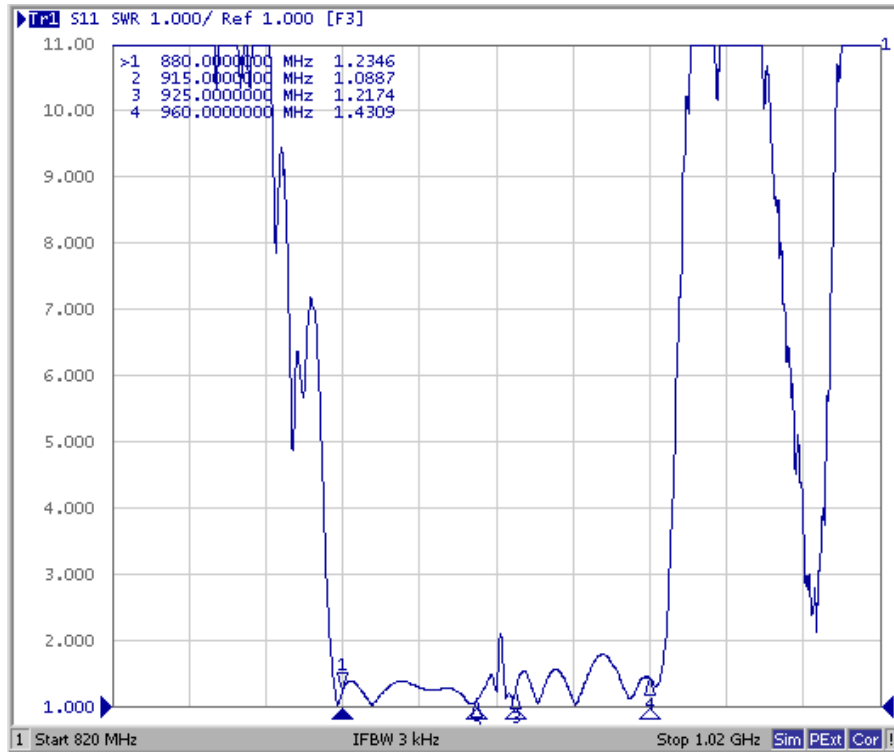

Tx to Ant (Wide span)

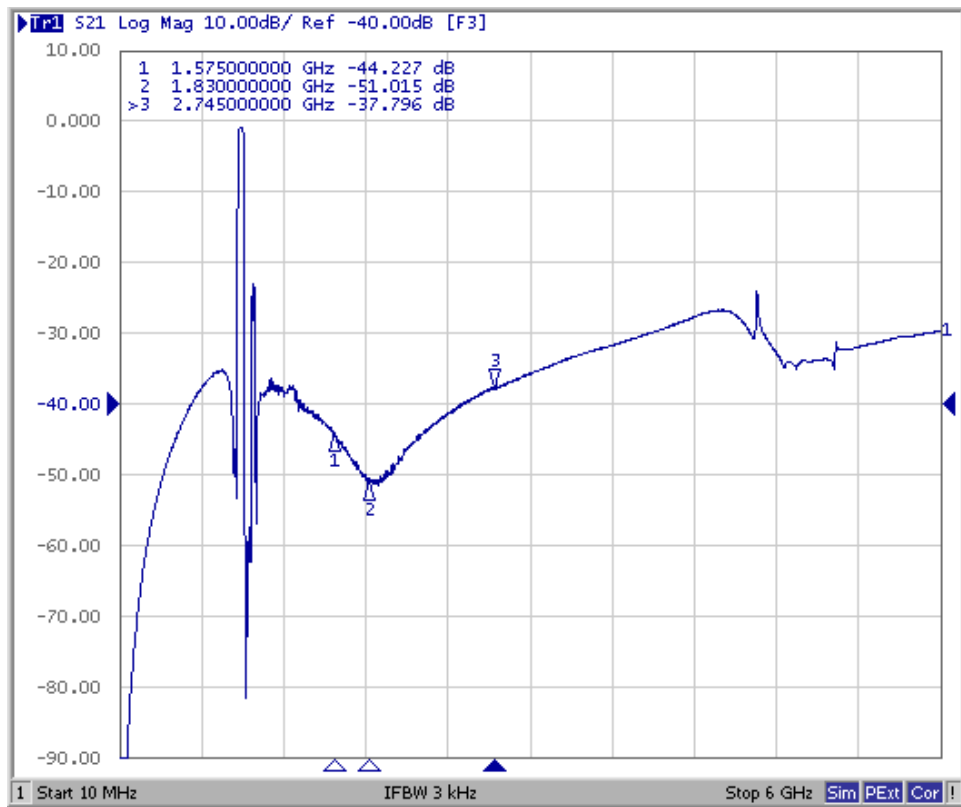

Ant to Rx (Wide span)

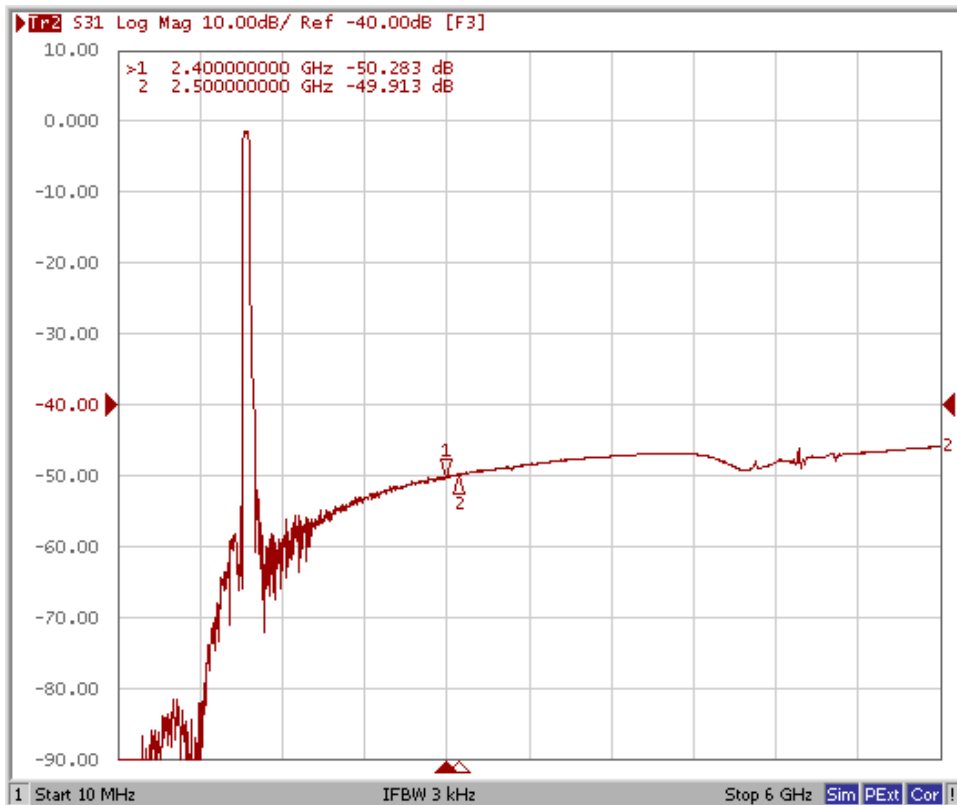

Outline Drawing

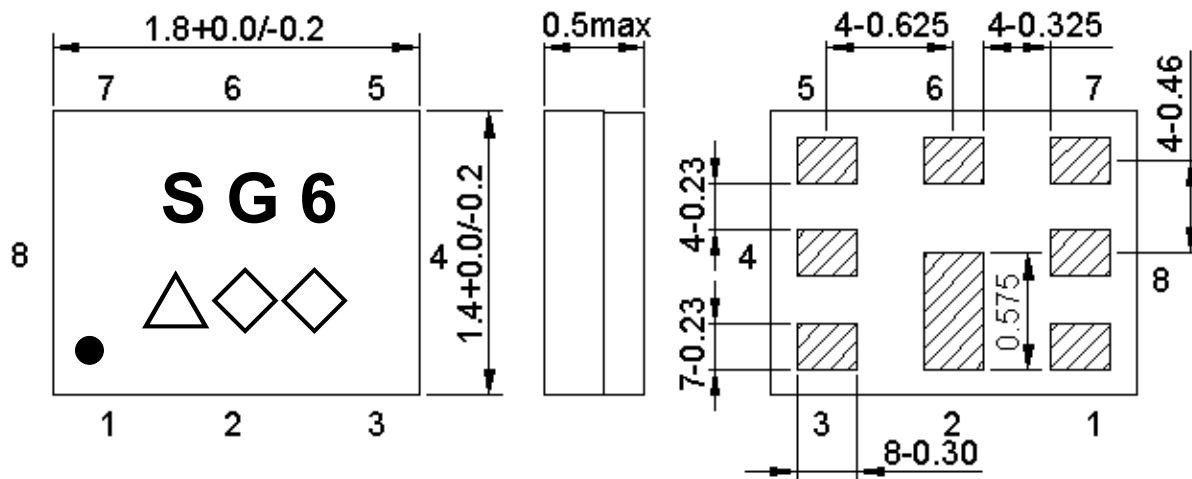

Marking name : **SG6**

△: Date code(2020 May → s ,....., 2023 Dec→ m.)

◇◇: Lot Code.

Product Date Code. Follow below table.

Year	Jan	Feb	Mar	Apr	May	Jun	Jul	Aug	Sep	Oct	Nov	Dec
2020	n	p	q	r	s	t	u	v	w	x	y	z
2021	A	B	C	D	E	F	G	H	J	K	L	M
2022	N	P	Q	R	S	T	U	V	W	X	Y	Z
2023	a	b	c	d	e	f	g	h	j	k	l	m

Pin Configuration

Pin No.	Pin name	Description
1	Rx	Receiver Pin
2	GND	Ground Pin
3	Tx	Transmitter Pin
4	GND	Ground Pin
5	GND	Ground Pin
6	ANT	Antenna Pin
7	GND	Ground Pin
8	GND	Ground Pin

Figure 1. Dimensions and Pin assignment

Evaluation Circuit

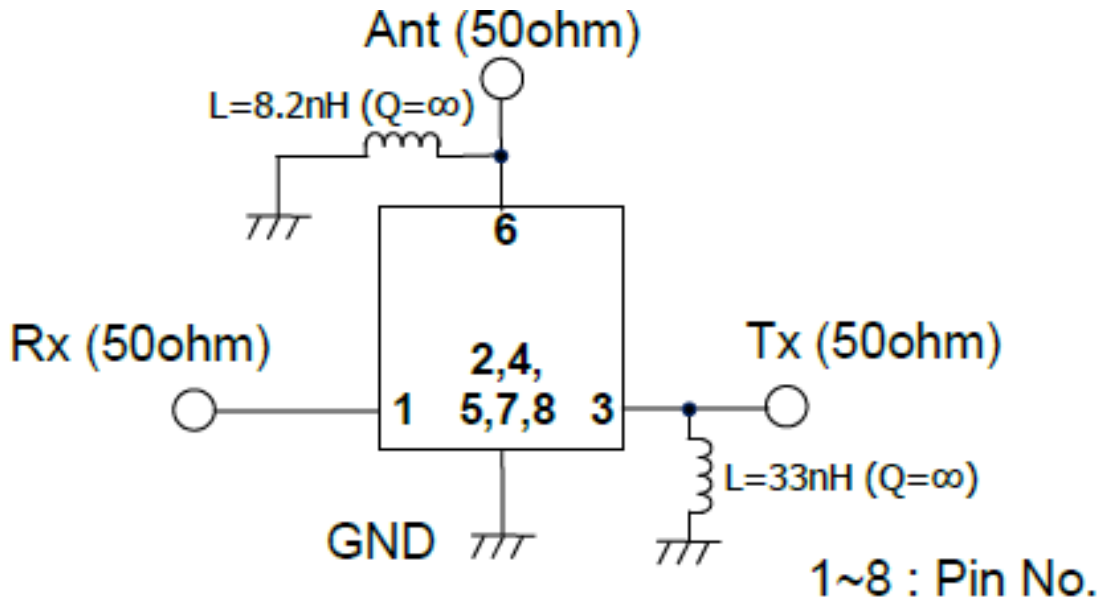
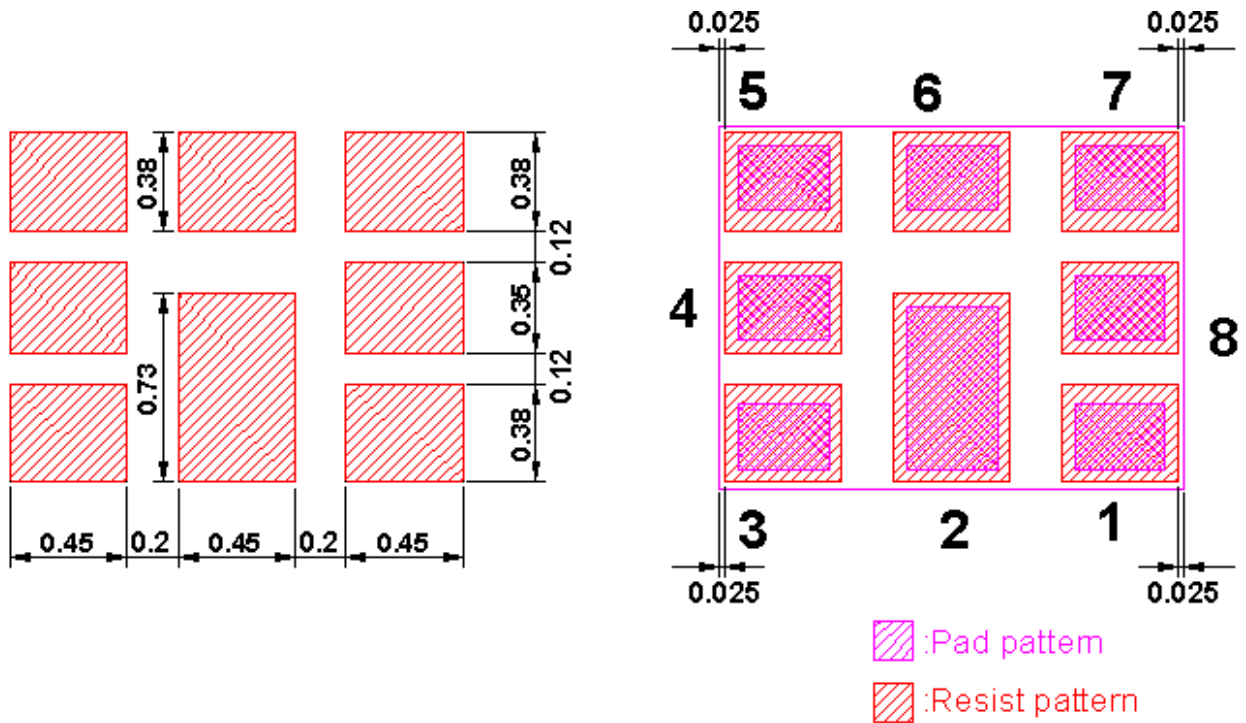

Figure 2. Evaluation Circuit

Footprint



Packing

Reel Dimension

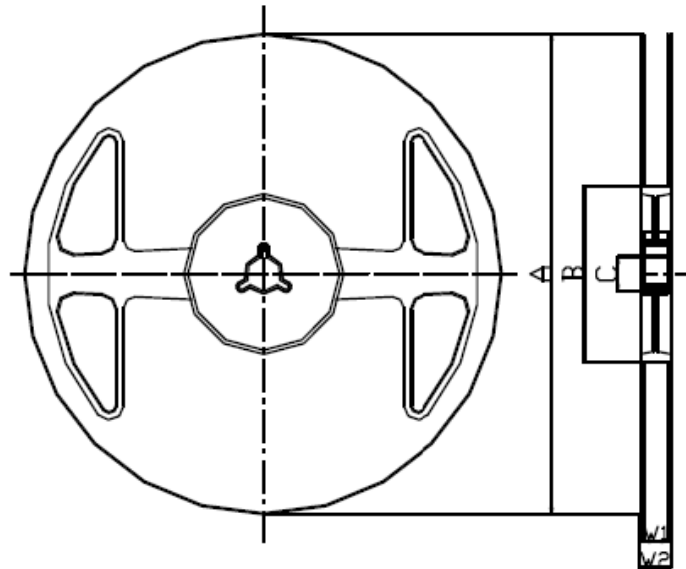

Materials of Reel

Material : Polystyrene + Carbon

Characteristics : Conforms to EIAJ-ET-7200A

Color : Black

Surface resistance (reference value) : $10^9 \Omega/\text{sq}$ Max.

Unit : mm

Code	Quantity	A	B	C	W1	W2
Z	3,000 pcs	$\phi 180.0 +0.0/-1.5$	$\phi 66.0 +/-0.5$	$\phi 13.0 +/-0.2$	$9.0 +1.0/-0.0$	$11.4 +/-1.0$

Recommended Reflow Profile

1. Preheating shall be fixed at 150~180°C for 60~90 seconds.
2. Ascending time to preheating temperature 150°C shall be 30 seconds min.
3. Heating shall be fixed at 220°C for 50~80 seconds and at 245~260°C peak (min. 10sec).
4. Time : 3 times.

