



RFM Integrated Device, Inc.

Part Number: SARCC314M37BXL1R05

PRODUCT SPECIFICATION

Description:
SAW RES, 314.370 MHz, +/-50
kHz, IL 2.2 dB

Date	June 4, 2014			AEC-Q200 Qualified
------	--------------	--	--	--------------------

1. Scope

This delivery specification specifies the 300MHz band surface acoustic wave resonator SARCC314M37BXL1R05 used for the oscillator. Please contact us in advance if you intend to use the product for other purposes.

Country of origin : TAIWAN (TAI-SAW TECHNOLOGY Co., Ltd.)

2. Customer Part Number

Customer No.		Customer dwg no.	
--------------	--	------------------	--

3. RFMi Part Number

SARCC314M37BXL1R05	Tape/Package (5000 pcs)
--------------------	-------------------------

4. Dimensions

4. External Dimensions

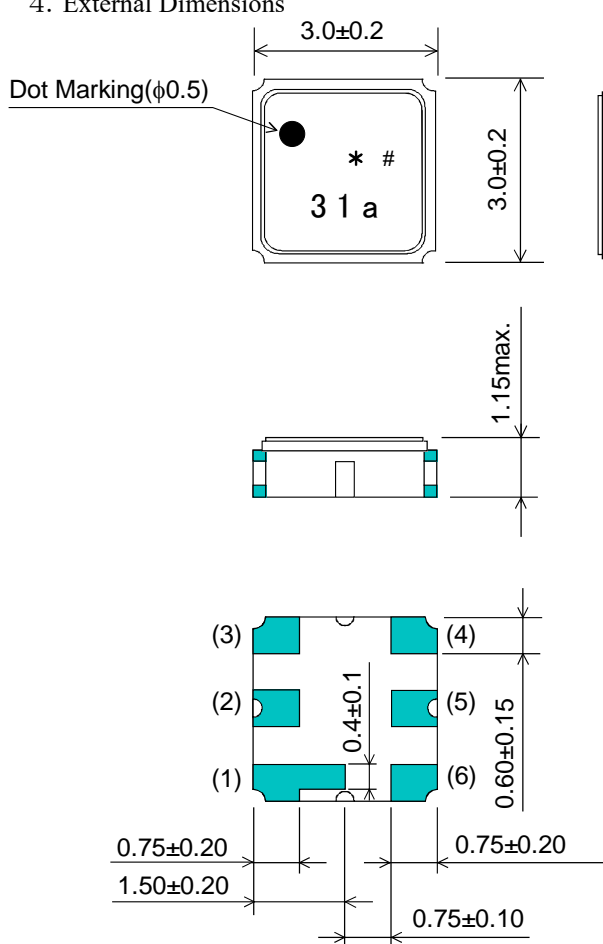

Marking : Laser Printing

* : EIAJ Code

Terminal(Surface) : Au
thickness 0.3...1.0 μ m
(Typ. 0.6 μ m)

Terminal(Base) : Ni
thickness 2.0...8.0 μ m
(Typ. 3.5 μ m)

Terminal Assignments

(2)(5) : Input
Others : Ground

Weight : 32 ± 5 mg

Coplanarity : 0.1mm max.

Unit : mm

4.2 Diagram

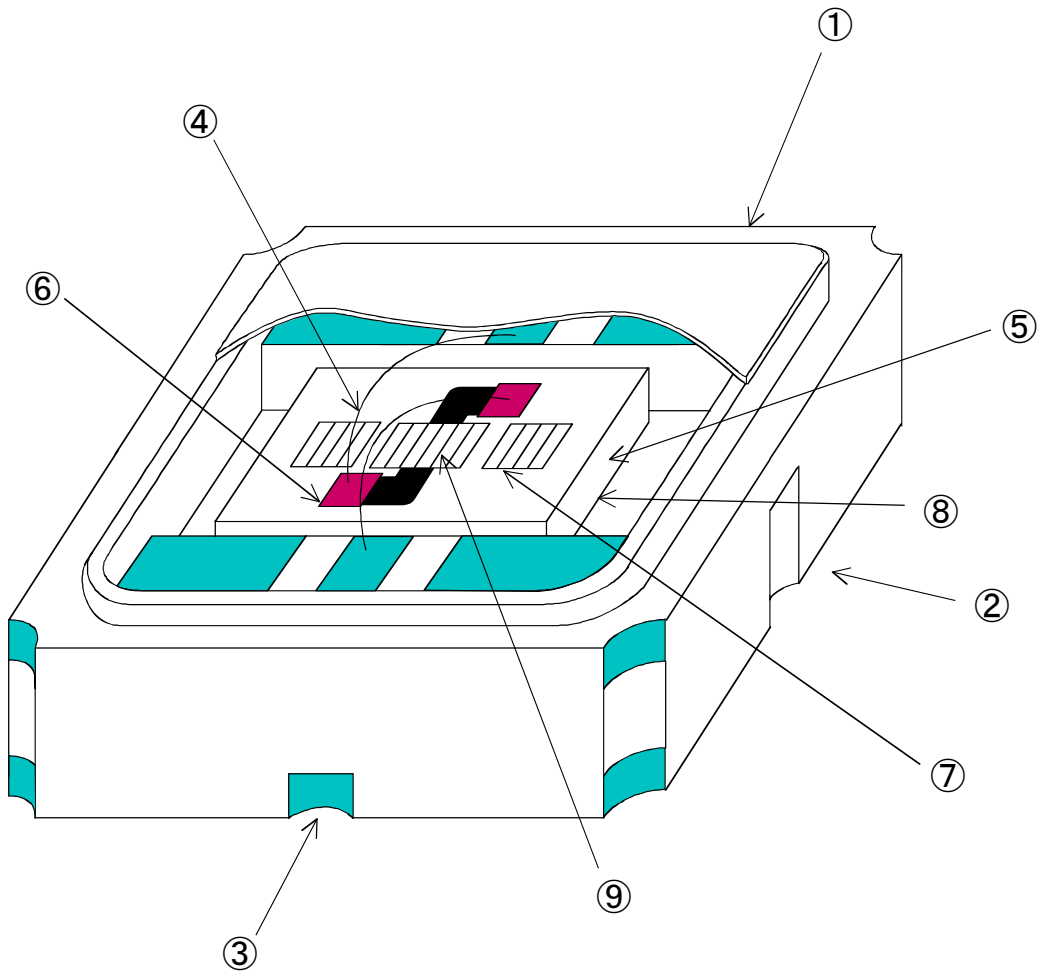

	Product Name	Material
①	Metal lid	Kovar, Ni plating
②	Multilayer ceramic	Alumina
③	Terminal	Au plating
④	Bonding wire	Al
⑤	Piezoelectric substrate	LiTaO3
⑥	Wire bonding pad	Al/Cu
⑦	I D T (Interdigital transducer)	Al/Cu
⑧	Protective film	SiO2

5. Maximum Rating

5.1	Withstanding Voltage for short term between the terminals	Maximum allowable capacity 10V (absolute resistance 100MΩ or more, 25 ± 2 °C)
5.2	D. C. Voltage between the terminals	Maximum allowable capacity 5V (25 ± 2 °C)
5.3	Allowable input level	10Vp-p However, commercial frequency
5.4	Operating Temperature	2mW
5.5	Storage Temperature	-40~+85°C
5.6	Input/output matching impedance (nominal value)	-40~+85°C

Applied voltage is 10V when measuring insulation resistance

6. Electrical Performance

(Within 25 ± 2 °C)

	Item	Specifications
6.1	Resonance frequency (center of 0.5 dB bandwidth)	Within 314.370 MHz ± 0.050 MHz
6.2	Resonance loss (at peak point)	2.2 dB or less
6.3	Parallel capacity However, the frequency shall be 1MHz. In addition, one terminal and the ground are parallel.	2.4 ± 0.5 pF
6.4	Ripple (within 0.5 dB band)	0.2 dB or less
6.5	This made more than 20 dB	20 dB or more

Standard test condition is standard temperature 25 ± 2 ° C, relative humidity 65 ± 5%. If there is no doubt about the judgment, test at temperature 5 ~ 35 ° C, relative humidity 45 ~ 85%. I will.

Item	Specifications	Conditions
Resonance frequency shift characteristic	Initial value within ± 60ppm	(Temperature of 25 ± 10 °C, Humidity of 65 ± 5%, 50000 hours)
Resonance frequency and temperature characteristics	Initial value + 10ppm ~ -100ppm	(+ 25 °C standard, -20 ~ + 60 °C)

Test Circuit

(a) Measurement Circuit

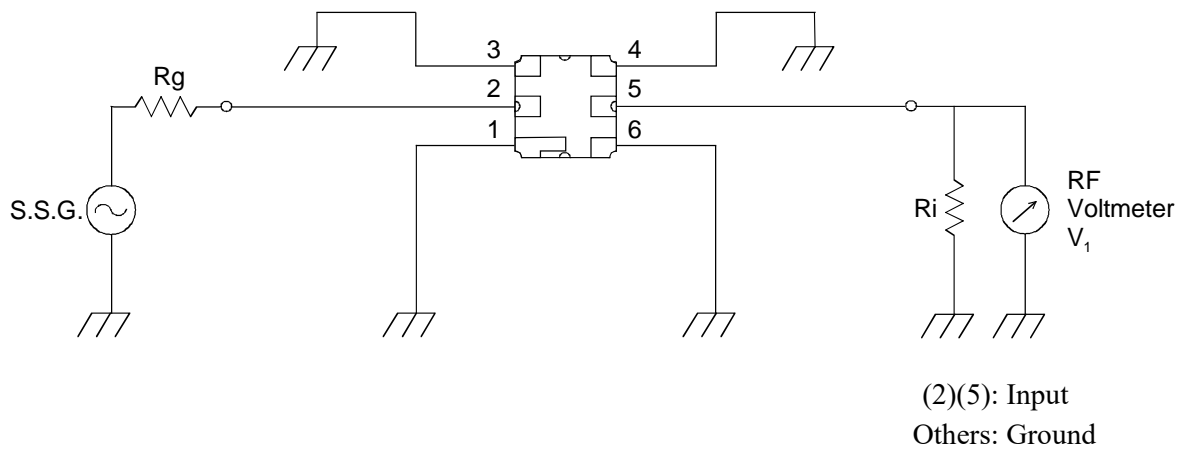

(b) 0dB level



R_g : 50Ω (Internal resistance of S.S.G.)

R_i : 50Ω (Input impedance of network analyzer or spectrum analyzer)

Resonant Loss or Insertion Loss = $20 \log (V_2 / V_1)$ [dB]

V_1 : Output Voltage of Test Circuit (a)

V_2 : Output Voltage of Test Circuit (b)

7. PHYSICAL AND ENVIRONMENTAL CHARACTERISTICS

	Test Item	Test Condition	Criteria
7.1	PCB Bend Strength	<p>This component is soldered onto the center of 0.8mm thickness PCB which is laid on the two small supporters spaced 90mm as shown in below figure. PCB is deflected to 2mm below from horizontal level by the pressing stick. The force is supplied for 1 second, 5 times repeatedly.</p> <p>Pressing Stick Unit:mm R10 φ5 Supporter Part ±1 off-set 45 45 2</p>	Satisfies Table 1 and does not cause any abnormality in the terminals and body.
7.2	Deflection strength 2	Solder on a board with a plate thickness of 1.6 mm, hold it in the same way as in 7.1, then press the center of the board 5 times at a rate of 1 second once for 1 second to bend the board 3 mm. return.	No abnormalities will occur in the terminals and body.
7.3	Vibration	<p>A sine vibration with a frequency of 10 to 500 Hz is applied in the X.Y.Z direction for 2 hours each as a cycle of 15 minutes.</p> <p>Amplitude condition 10 ~ 55Hz: amplitude 0.75mm 55 ~ 500Hz: acceleration amplitude 98m / s²</p>	Satisfies Table 1.
7.4	Shock resistance	Apply a load of 100g from a height of 150cm and drop it on a hard floor 5 times for 6 sides.	
7.5	Solderability	The terminals were immersed in a rosin ethanol solution (rosin ratio 20-25%) for about 5 seconds, and then H63A, H60A, or Sn-3.0Ag-0.5Cu of JIS-Z-3282 was melted at 230 ± 5 ° C. Immerse in solder bath for 5 ± 0.5 seconds.	90% minimum of the immersed surface should be covered with solder.
7.6	Resistance to solder heat	After preheating at 170 ± 10 ° C for 90 seconds or more, immerse in solder at 255 ± 5 ° C for 3 ± 1 seconds so that all electrodes are completely hidden. Remove from the bath to room temperature and measure 2 hours later.	Satisfies table 2
7.7	Temperature Characteristics	Measure in the range of -40 to + 85 ° C.	Satisfies table 3
		Measure in the range of -20 to + 60 ° C.	Satisfied table 4
7.8	Humidity	Hold in a constant temperature and humidity chamber at a temperature of 60 ° C and relative humidity of 90 to 95% for 750 hours, take out to room temperature and measure 2 hours later.	Satisfies table 2
7.9	Life Test High Temperature	Hold in a constant temperature bath at a temperature of 85 ° C for 750 hours, take out to room temperature and measure 2 hours later.	
7.10	Life Test Low Temperature	Keep in a constant temperature bath of -40 ° C for 500 hours, take out to room temperature and measure 2 hours later.	
7.11	Thermal Shock	-40 ° C for 30 minutes and + 85 ° C for 30 minutes are set as 1 cycle, and after 500 cycles of this, remove to room temperature. Measure 2 hours later.	
7.12	Resistance Reflow Soldering	The electrical performance is measured after being soldered by reflow 2 times with the following reflow profile A or B (see page 8) and then being placed in standard atmospheric conditions for 24 hours.	

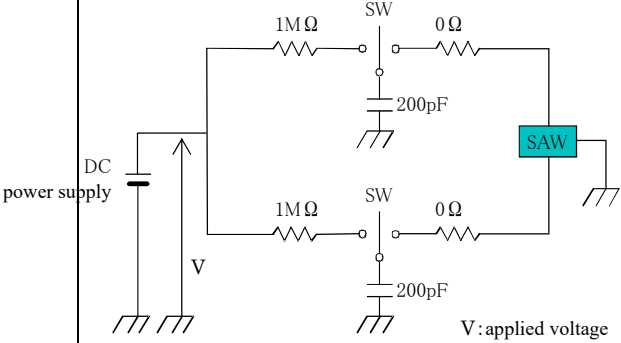
	Test Item	Test Condition	Criteria
7.12	Surge resistance	<p>Investigate and measure the voltage at the cumulative failure probability $F(t) = 10\%$ point on the Weibull probability paper with surge withstand voltage. (Measuring method)</p> <p>In the circuit diagram below, step up the DC voltage from 39V at intervals of the E12 series, and measure the voltage that causes the product to fail.</p> <p>No. of samples: 30 pcs or more</p> <p>Voltage application times: 1 time/step, (C=200pF)</p>  <p>V: applied voltage</p> <p>Based on this result, the relationship between the applied voltage and the cumulative failure probability $F(t)$ is plotted on the Weibull probability paper and the surge voltage life distribution is confirmed.</p> <p>(Fault judgment criteria) When the amount of change (deterioration) in resonance loss (at the peak point) from the initial value is 0.3 dB or more, it is judged as a failure (even within the specifications, it is judged as a failure).</p>	150V 以上を満足します。
7.13	Salt spray resistance	Spray salt water at a temperature of 35 ° C and a concentration of $5 \pm 1\%$ for 48 hours, wash with water and dry, and then measure 2 hours later.	Satisfies table 2

Item	Specifications
Resonance frequency (center of 0.5 dB bandwidth)	Initial value \pm 20 kHz or less
Resonance loss (at peak point)	2.2 dB or less
Parallel Capacitance at 1MHz One terminal is connected to ground.	$2.4 \pm 0.5\text{pF}$
Ripple (within 0.5 dB band)	0.2 dB or less

Table 1

Item	Specifications
Resonance frequency (center of 0.5 dB bandwidth)	Initial value \pm 30 kHz or less
Resonance loss (at peak point)	2.7 dB or less
Parallel capacity However, the frequency shall be 1MHz. In addition, one terminal and the ground are parallel.	$2.4 \pm 0.5\text{pF}$
Ripple (within 0.5 dB band)	0.2 dB or less

Table 2

Item	Specifications
Resonance frequency (center of 0.5 dB bandwidth)	Based on + 25 °C Initial value + 10ppm to -200ppm or less
Resonance loss (at peak point)	2.7 dB or less
Parallel capacity However, the frequency shall be 1MHz. In addition, one terminal and the ground are parallel.	$2.4 \pm 0.5\text{pF}$
Ripple (within 0.5 dB band)	0.2 dB or less

Table 3

Item	Specifications
Resonance frequency (center of 0.5 dB bandwidth)	Based on + 25 °C Initial value + 10ppm \sim -100ppm or less
Resonance loss (at peak point)	2.7 dB less
Parallel capacity However, the frequency shall be 1MHz. In addition, one terminal and the ground are parallel.	$2.4 \pm 0.5\text{pF}$
Ripple (within 0.5 dB band)	0.2 dB less

Table 4

Reflow Profile

- 1) Set the preheat temperature to 170-190 °C for 110 seconds.
- 2) The heating speed to the preheat temperature of 170 °C shall be 40 seconds or more.
- 3) The heating temperature shall be 200 °C for 70 seconds and 220 °C for 50 seconds, and the peak temperature shall be 240 ± 5 °C.

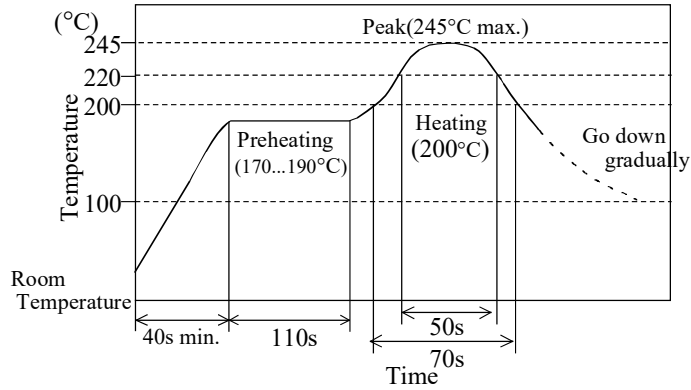

Recommended Land Pattern

- 1) Recommended land pattern is as follows.

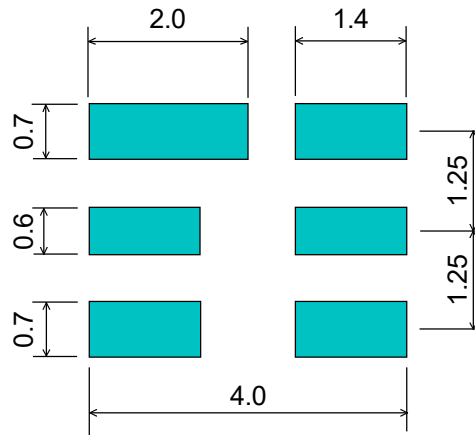

 : Land Pattern
Unit : mm

8. TAPING METHOD OF PLASTIC TAPE PACKAGE

8.1 The components are packed to be prevented from being damaged. Part number, quantity and inspection number are indicated on each minimum packing unit.

8.2 Dimensions of Plastic Tape See Figure. 2.

8.3 Taping Method

- 1) The tape shall be wound clockwise. (The feeding holes shall be to the right side when the tape is pulled toward user.)
- 2) Cover tape shall not cover the feeding holes of cavity tape or overlap the edge of cavity tape.
- 3) Trailer tape shall be 160~190 mm and leader cavity shall be 80~120 mm (refer to Figure. 1.)
- 4) The tip of the cover tape shall be adhered to the side of reel with adhesive tape (50~120 mm: Reference value).
- 5) The cover tape peel strength force shall be 0.2~0.6N (Reference value) which measured at 170 degrees with respect to the carrier tape.
- 6) The orientation is ruled as Figure. 2 shows.
- 7) All the filters shall be packed continuously into the tape without vacant cavities except the leader cavity and trailer tape area.
- 8) A reel shall contain 5000 pcs of filters.
(Please place the order with 5000 pcs times integer number. In case of small quantity shipment, bulk packing may be applied.)
- 9) Cover tape and cavity tape are made of anti-static material.
- 10) Part number, customer part number, quantity and inspection lot number shall be marked on each reel. (The reel side containing the label will visible when the reel is oriented in a direction that dispenses the tape from the top of the reel and in a clockwise direction.)
- 11) The product which has ROHS-Y<*> mark on the packaging label is compliance with RoHS directives. The alphabet in blank <*> will be changed A to B, B to C, and so on with every revision of the RoHS directives. Please refer to the document, "The Marking for the directives on the restriction of the hazardous substances' use," to check the directives corresponding to alphabets in <*>.

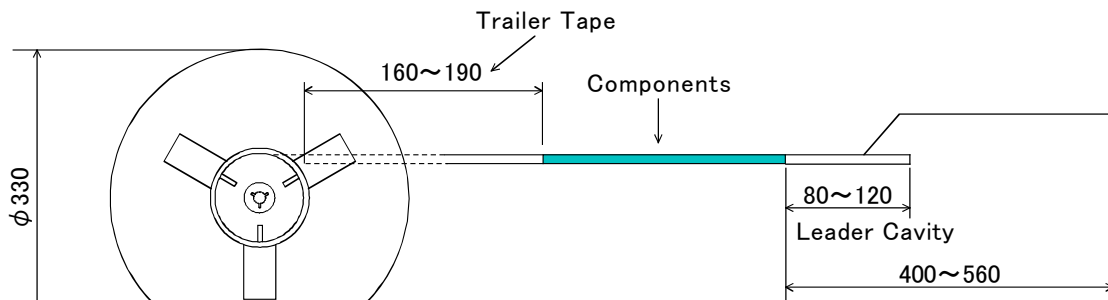
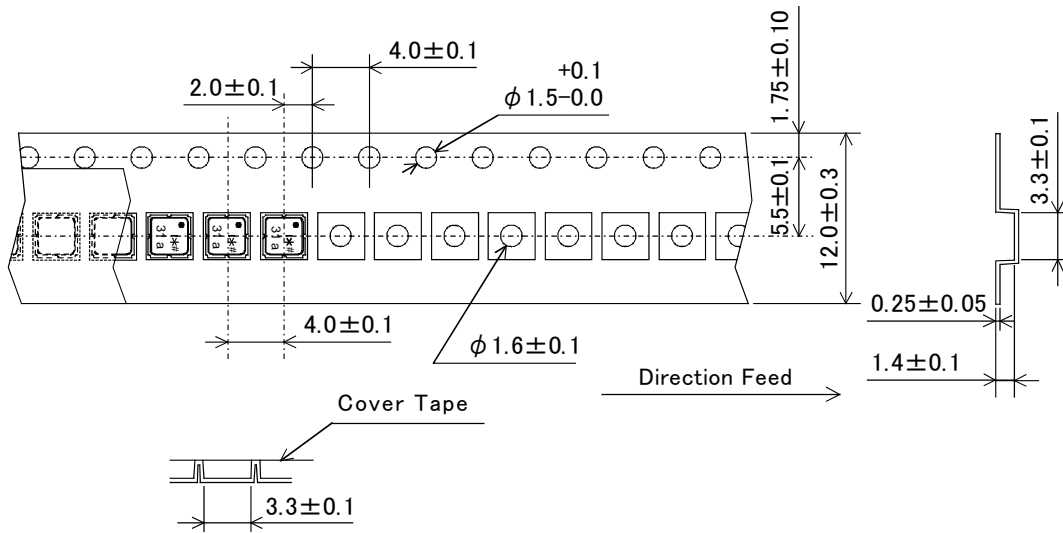
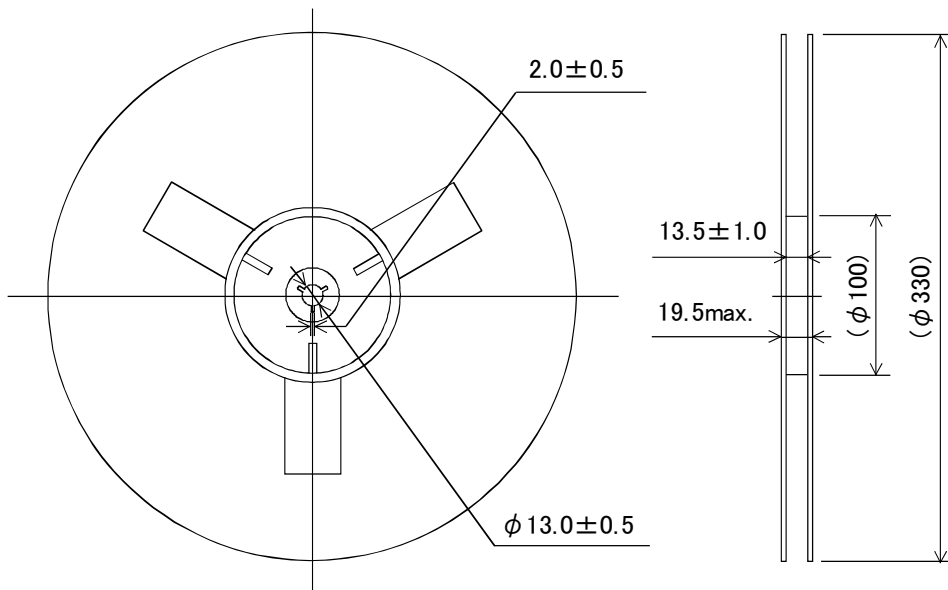

Figure1

Dimensions of Carrier Tape



Dimensions of Reel



Unit : mm

Figure 2

9. NOTICE

9.1 Usage Conditions

- 1) Use this component within operating temperature range. It might not meet the specification of electrical performance out of operating temperature range. Usage on the condition of exceeding operating temperature range might cause degradation or destruction of the component. Even a short time usage on such conditions might cause degradation of reliability.

- 2) This product is designed for use of electrical equipment in the standard environment (temperature, humidity, atmospheric pressure etc.) Do not use in the following environments, since it causes degradation of characteristics and reliability.
 - Ambient air containing corrosive gas (Cl₂, H₂S, NH₃, SO_x, NO_x, etc.)
 - Ambient air containing combustible gas and substance with high volatility
 - In dusty place
 - In the places where the water splashes or precipitates
 - Under direct sunlight
 - In the places under the strong influence of static electricity or electric fieldContact us before using the component in such conditions.

- 3) This component can not be used in liquid (water, oil, chemical solution, organic solvents, etc.)

- 4) Apply electrical power lower than specified in the specification. When the component is used with higher rating power than specified in the specification, it might cause degradation or destruction of the component. Even if a short time, it might cause degradation of reliability under such a condition.

- 5) Do not let the component contact with other components, since its coating is not insulated.

9.2 Storage Conditions

- 1) Keep the component in the package or sealed container on the following conditions.
[Temperature: -10~+40°C, Humidity: 30~85% R.H.]
Examine solderability before using this component, after longer than 6 months storage since it might cause degradation of solderability. Notice that long-term storage might cause discoloration.

- 2) To keep solderability of outer-electrode, do not store in the following environments.
 - Ambient air containing corrosive gas (Cl₂, H₂S, NH₃, SO_x, NO_x, etc.)
 - Ambient air containing combustible gas and substance with high volatility
 - In dusty place
 - In the places where the water splashes or precipitates
 - Under direct sunlight
 - In the places under the strong influence of static electricity or electric fieldContact us before using the component in such conditions.

- 3) Do not open the package until usage.

9.3 Soldering Conditions

1) Solder on the following condition. Contact us before soldering this component on conditions other than following since it might cause destruction.

a. Soldering with soldering iron

- Preheating condition : 150±20°C, 60 seconds min.
- Temperature at the tip of the soldering iron : 260±10°C or 350±5°C
- Duration : 3 seconds max.
- Diameter at the tip of the soldering iron : φ3mm max.
- Power of soldering iron : 30W max.

Avoid the contact with iron other than back or side terminals part.

b. Reflow soldering

- Solder on the reflow soldering condition specified in this specification

2) Use land pattern recommended in this specification, since excess solder might cause destruction of chip by mechanical stress to supply too much solder.

3) Use rosin flux. Do not use strong acid flux [ex. Flux with more than 0.2wt% Halogen compound content (converted to chlorine content.)]

4) Use JIS-Z-3282 H63A, H60A, H50A solder or Lead free solder (Sn-3.0Ag-0.5Cu). Contact us before using other solders than above.

5) Solder with reflow soldering. Soldering with soldering iron shall be soldered on the condition specified in this specification. Since the lack of preheating gives this component rapid temperature change, it might cause degradation and destruction. Contact us before using the component on other conditions than specified in this specification.

6) Notice that the duration of soldering with soldering iron must be considered to be accumulated time, when soldering is repeated.

7) Use this component after examining that the outer electrodes are smoothly covered with solder thicker than 0.1mm.

9.4 Cleaning Conditions

- 1) Isopropyl alcohol and ethyl alcohol can be used for cleaning. Contact us before using other cleaning solvents than above. Do not use flon, trichloroethane etc in the point of view to protect for global environment.
- 2) Clean this component after ensuring that the temperature of the component is room temperature, since rapid temperature change by cleaning after reflow soldering might cause degradation or destruction.
- 3) Do not use ultrasonic cleaning, since ultrasonic vibration might cause degradation or destruction.
- 4) Dry this component immediately after cleaning.
- 5) In the case that cleaning process is included in the manufacturing process, examine the influence to the performance of the component with mounting on PCB before use.

9.5 Handling Conditions

- 1) Notice that it might cause destruction to apply larger shock than specified in the specification while handling.
- 2) Notice that it might cause reliability degradation to apply excessive shock or vibration during transportation.
- 3) Do not apply any shock or pressure to this component during transportation when the component is on PCB.
- 4) Do not apply static electricity or excessive voltage while assembling and measuring, since it might cause degradation or destruction to apply static electricity to this component.
- 5) Do not handle this component with bare hand.

9.6 Mounting Conditions

- 1) Mount this component not to apply a stress caused by warp or bend of PCB.
- 2) Abraded positioning claw, pick-up nozzle, etc of component placement machine might apply excessive shock on the component on PCB and cause destruction. Keep the maintenance which is instructed on each machine regularly to prevent the component from these kinds of troubles.
- 3) Mount all terminals, or terminal strength might be degraded.
- 4) Mount the component on PCB with no space between component and PCB.

9.7 Limitation of Applications

Please contact us before using our products for the applications listed below which require especially for the prevention of defects which might directly cause damage to the third party's life, body or property.

- a. Aircraft equipment
- b. Aerospace equipment
- c. Undersea equipment
- d. Nuclear control equipment
- e. Medical equipment
- f. Transportation equipment (vehicles, trains, ships, etc.)
- g. Traffic signal equipment
- h. Disaster prevention / crime prevention equipment
- i. Data - processing equipment
- j. Application of similar complexity and / or reliability requirements to the applications listed in the above

NOTE

- 1) Please make sure that your product has been evaluated in view of your specifications with our product being mounted to your product.
- 2) You are requested not to use our product deviating from the agreed specifications.
- 3) We consider it not appropriate to include any terms and conditions with regard to the business transaction in the product specifications, drawings or other technical documents. Therefore, if your technical documents as above include such terms and conditions such as warranty clause, product liability clause, or intellectual property infringement liability clause, they will be deemed to be invalid.

Others

This product conforms to the provisions on the control of "Environmental Hazardous Substances" in Alps Electric Co.,Ltd.,Green Procurement Standard.