

ANT1051
Dielectric Chip
Antenna

Frequency Range

2450 MHz

Package
Dimensions
2.05 x 1.23 x 0.45 mm

1.Scope

This specification covers the [dielectric chip antenna](#) for [Bluetooth / WLAN Applications](#).

2.Name of the product

This product is named “[Dielectric Chip Antenna](#)”.

3.Electrical characteristics

3-1 Electrical characteristics of antenna

The antenna has the electrical characteristics given in Table 1 under the standard installation conditions shown in the figure of Evaluation Board.

Table 1

No	Parameter	Specification
1	Central Frequency	2450 MHz
2	Bandwidth	85 MHz (Min.)
3	Return Loss	-6.5 dB(Max)
4	Peak Gain	1.72 dBi
5	Impedance	50 Ohm
6	Operating Temperature	-40°C ~ +110°C
7	Maximum Power	4 W
8	Resistance to Soldering Heats	10 sec. (@ 260°C)
9	Polarization	Linear
10	Azimuth Beam width	Omni-directional
11	Termination	Ni / Au (Leadless)

• Remark: Bandwidth & Peak Gain was measured under evaluation board of next page

4. Antenna & Demo Board Dimension

4-1 Antenna Dimension

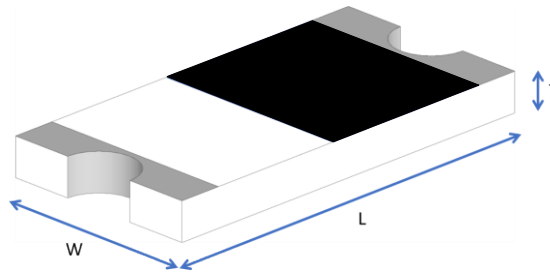

	Dimension (mm)
L	2.05 ± 0.20
W	1.23 ± 0.20
T	0.45 ± 0.20

4-2 Recommended PCB Pattern

Evaluation Board Dimension (board size 80x40mm)

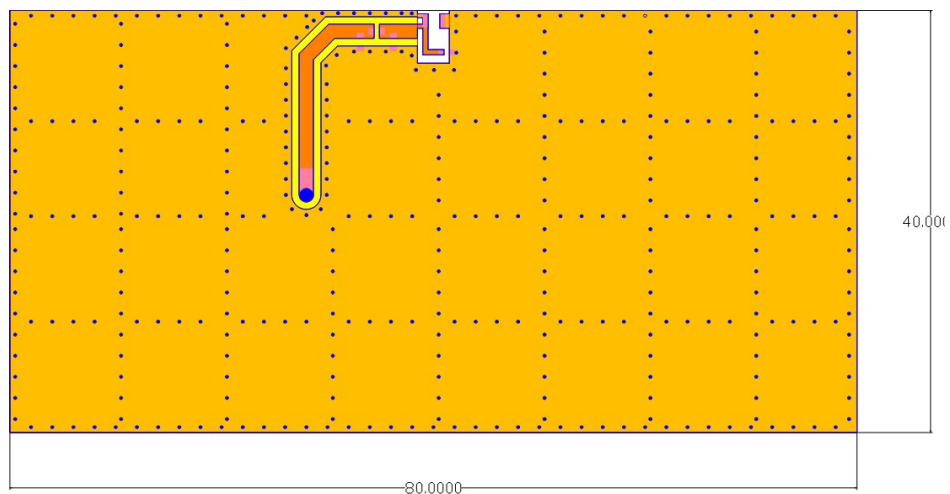

2nd Evaluation Board Dimension
Evaluation Board Dimension (board size 80x40mm)

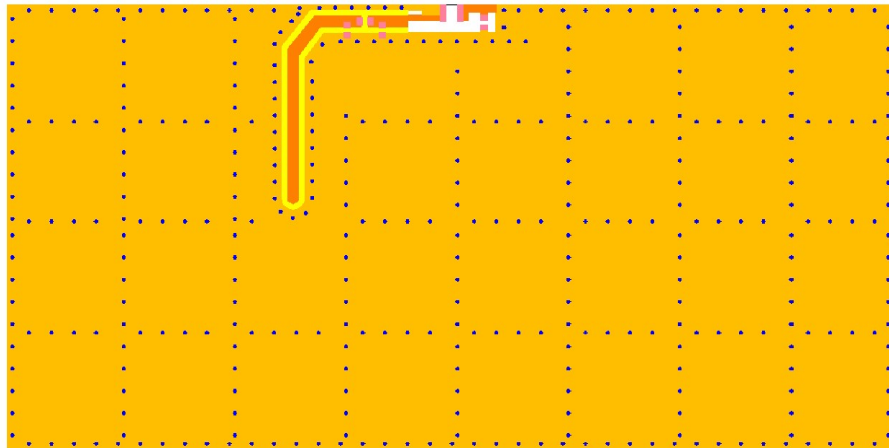

Suggest Matching Circuit

Note:

Suggest using low tolerance component, inductor $\pm 0.1 \sim 0.3 \text{ nH}$, Capacitor $\pm 0.1 \text{ pF}$

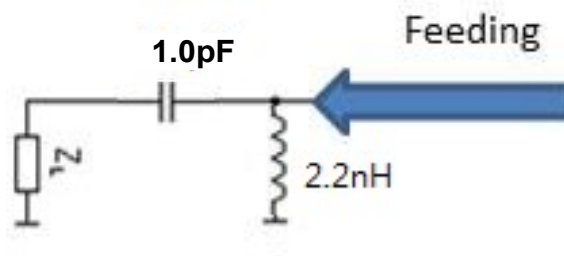

Layout Dimensions in Clearance area (Size=3.0*5.0mm)

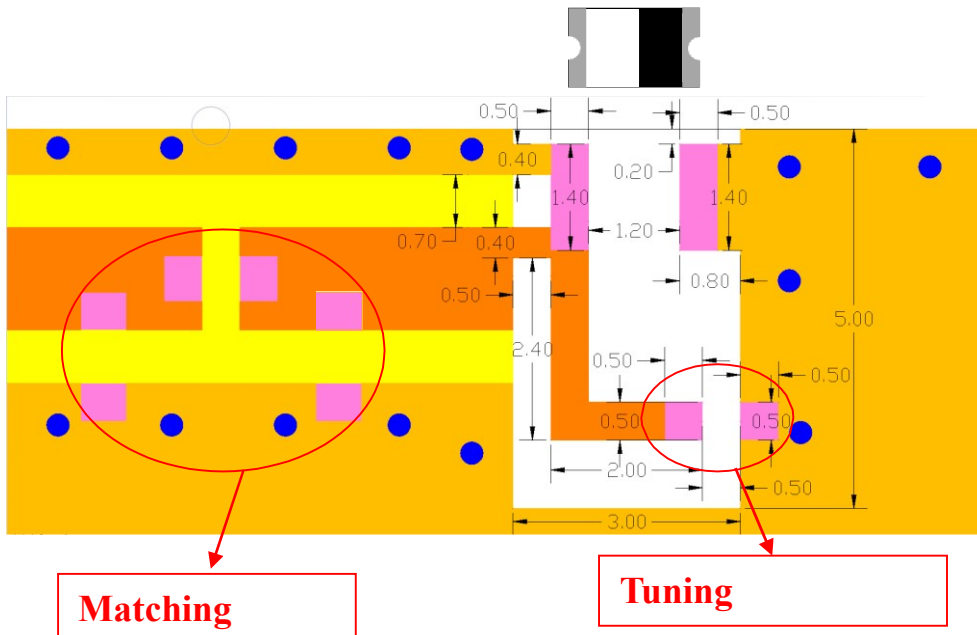

Footprint (Unit: mm)

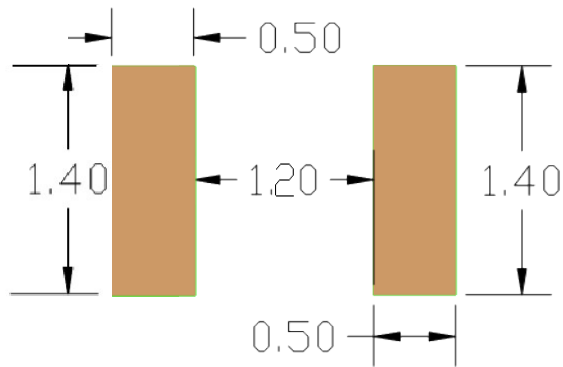

2nd Layout Dimensions in Clearance area (Size=8.0*2.5mm)

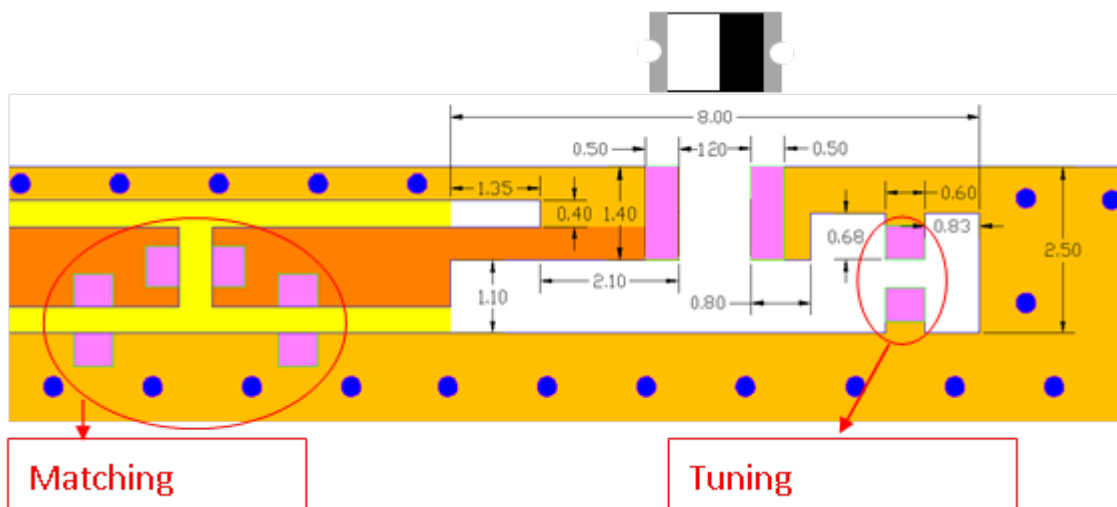

5.Measurement Results

Return Loss

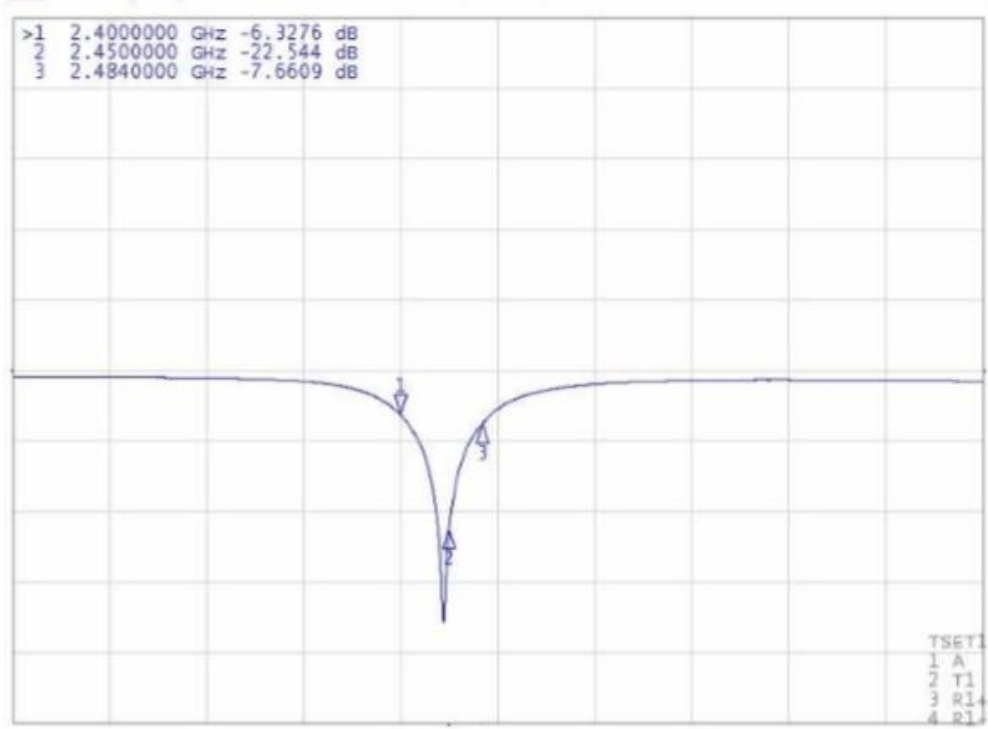

Radiation Pattern

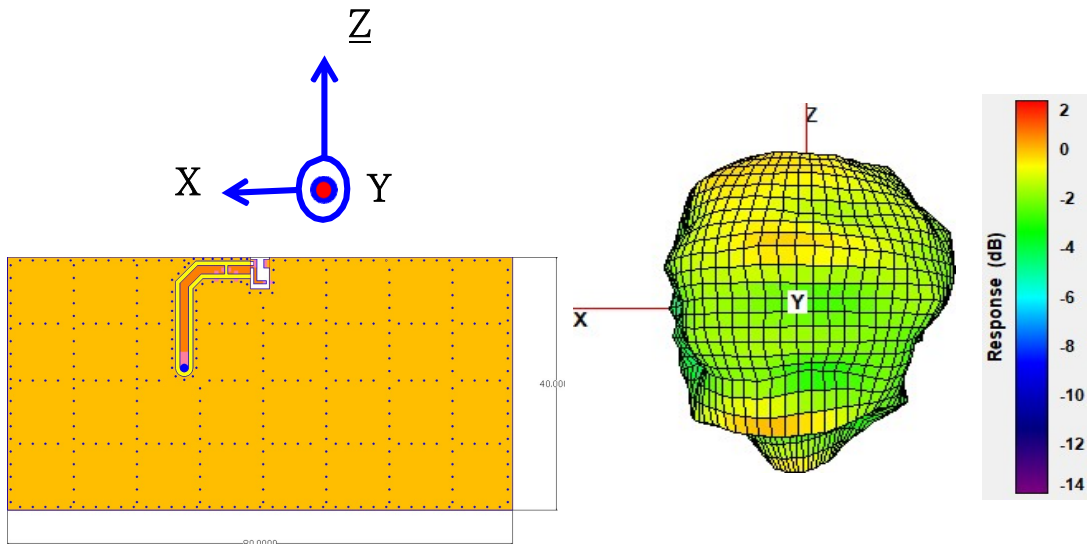

	Efficiency	Peak Gain	Directivity
2400MHz	63.12 %	1.62dBi	3.61dBi
2450MHz	70.56 %	1.72dBi	3.23dBi
2500MHz	65.48 %	1.64dBi	3.47dBi

Chamber Coordinate System

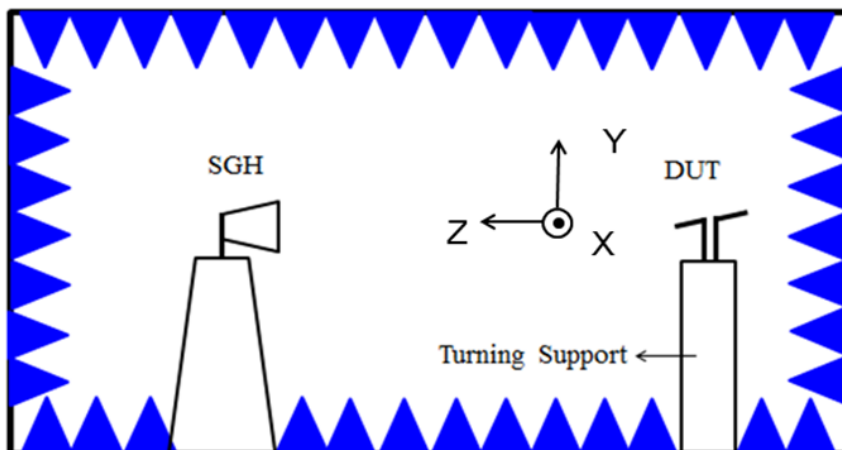

6. Reliability and Test Conductions

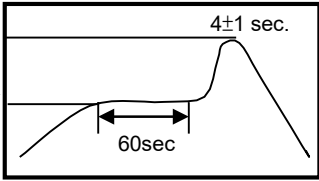
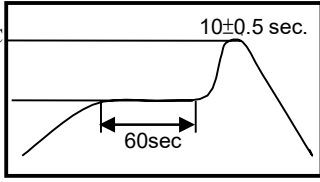
ITEM	REQUIREMENTS	TEST CONDITION															
solder ability	1. Wetting shall exceed 90% coverage 2. No visible mechanical damage. TEMP (°C) 	Pre-heating temperature: 150°C/60sec. Solder temperature: 230±5°C Duration: 4±1sec. Solder:Sn-Ag3.0-Cu0.5 Flux for lead free: rosin															
Solder heat Resistance	1. No visible mechanical damage. 2. Central Freq. change :within ±6% TEMP (°C) 	Pre-heating temperature: 150°C/60sec. Solder temperature: 260±5°C Duration: 10±0.5sec. Solder:Sn-Ag3.0-Cu0.5 Flux for lead free: rosin															
Component Adhesion (Push test)	1. No visible mechanical damage.	The device should be reflow soldered (230±5°C for 10sec.) to a tinned copper substrate A dyno meter force gauge should be applied the side of the component. The device must with-ST-F 0.5 Kg without failure of the Termination attached to component.															
Component Adhesion (Pull test)	1. No visible mechanical damage.	Insert 10cm wire into the remaining open eye bend, the ends of even wire lengths upward and wind together. Terminal shall not be remarkably damaged.															
Thermal shock	1. No visible mechanical damage. 2. Central Freq. change :within ±6% <table border="1" data-bbox="411 1229 836 1476"> <thead> <tr> <th>Phase</th> <th>Temperature(°C)</th> <th>Time(min)</th> </tr> </thead> <tbody> <tr> <td>1</td> <td>+110±5°C</td> <td>30±3</td> </tr> <tr> <td>2</td> <td>Room Temperature</td> <td>Within 3sec</td> </tr> <tr> <td>3</td> <td>-40±2°C</td> <td>30±3</td> </tr> <tr> <td>4</td> <td>Room Temperature</td> <td>Within 3sec</td> </tr> </tbody> </table>	Phase	Temperature(°C)	Time(min)	1	+110±5°C	30±3	2	Room Temperature	Within 3sec	3	-40±2°C	30±3	4	Room Temperature	Within 3sec	+110°C=>30±3min -40°C=>30±3min Test cycle:10 cycles The chip shall be stabilized at normal condition for 2~3 hours before measuring.
Phase	Temperature(°C)	Time(min)															
1	+110±5°C	30±3															
2	Room Temperature	Within 3sec															
3	-40±2°C	30±3															
4	Room Temperature	Within 3sec															
Resistance to High Temperature	1. No visible mechanical damage 2. Central Freq. change :within ±6% 3. No disconnection or short circuit.	Temperature: +110±5°C Duration: 1000±12hrs The chip shall be stabilized at normal condition for 2~3 hours before measuring.															
Resistance to Low Temperature	1. No visible mechanical damage 2. Central Freq. change :within ±6% 3. No disconnection or short circuit.	Temperature:-40±5°C Duration: 1000±12hrs The chip shall be stabilized at normal condition for 2~3 hours before measuring.															
Humidity	1. No visible mechanical damage 2. Central Freq. change :within ±6% 3. No disconnection or short circuit.	Temperature: 40±2°C Humidity: 90% to 95% RH Duration: 1000±12hrs The chip shall be stabilized at normal Condition for 2~3 hours before measuring.															

7. Soldering and Mounting

Mildly activated rosin fluxes are preferred. The minimum amount of solder can lead to damage from the stresses caused by the difference in coefficients of expansion between solder, chip and substrate. The terminations are suitable for all wave and re-flow soldering systems. If hand soldering cannot be avoided, the preferred technique is the utilization of hot air soldering tools.

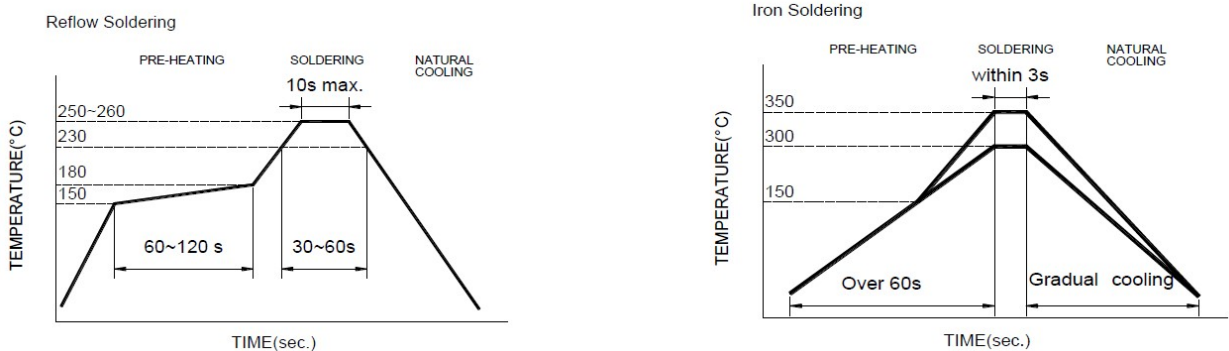

Recommended temperature profiles for re-flow soldering in Figure 1.

Products attachment with a soldering iron is discouraged due to the inherent process control limitations. In the event that a soldering iron must be employed the following precautions are recommended.

- Preheat circuit and products to 150°C
- Never contact the ceramic with the iron tip
- Use a 20 watt soldering iron with tip diameter of 1.0mm
- 280°C tip temperature (max)
- 1.0mm tip diameter (max)
- Limit soldering time to 3 sec.

8. Packaging Information

Tape Specification:

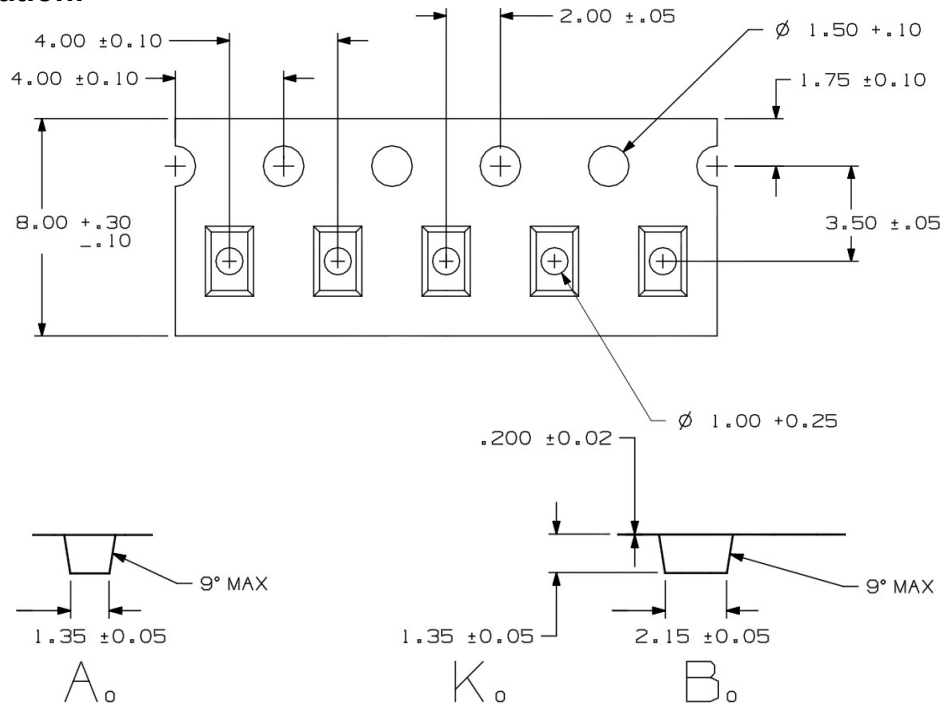

Reel Specification: (7", $\Phi 180$ mm)

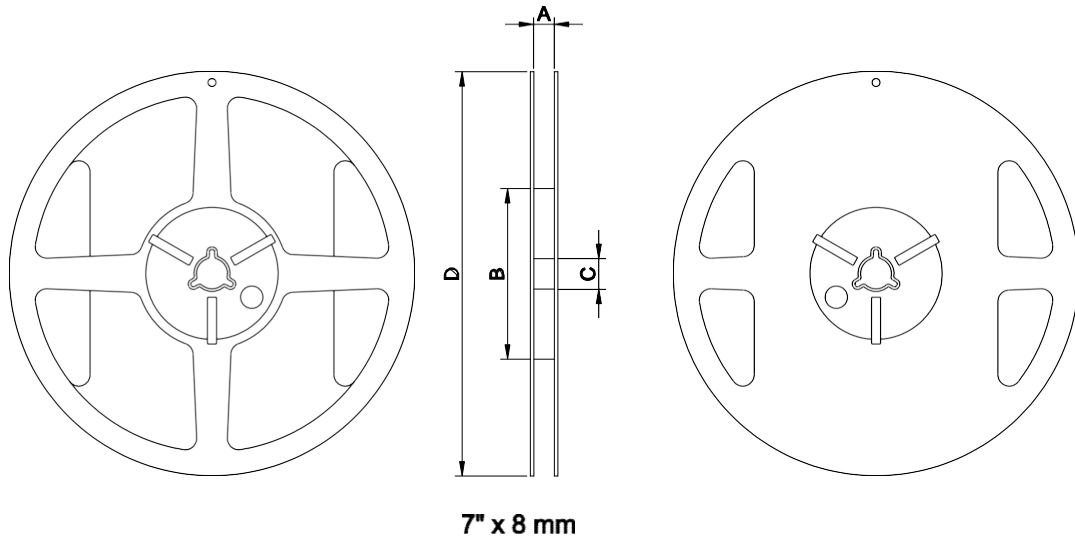

Tape Width(mm)	A(mm)	B(mm)	C(mm)	D(mm)	Chip/Reel(pcs)
8	9.0 ± 0.5	60 ± 2	13.5 ± 0.5	178 ± 2	3000

9. Storage and Transportation Information

Storage Conditions

To maintain the solder ability of terminal electrodes:

1. Temperature and humidity conditions: -10~ 40 °C and 30~70% RH.
2. Recommended products should be used within 6 months from the time of delivery.
3. The packaging material should be kept where no chlorine or sulfur exists in the air.

Transportation Conditions

1. Products should be handled with care to avoid damage or contamination from perspiration and skin oils.
2. The use of tweezers or vacuum pick up is strongly recommended for individual components.
3. Bulk handling should ensure that abrasion and mechanical shock are minimized.