

A. GENERAL DESCRIPTION:

1. The RXM7000 is a front-end module (FEM) designed for GNSS including GPS, GLONASS, BeiDou, and Galileo applications.
2. The RXM7000 offers low noise figure, high linearity, and high out-band rejection characteristics brought by included high performance pre-SAW filter and low noise amplifier (LNA).
3. The RXM7000 only two external components and very small package that is 1.5x1.1mm.

B. RECOMMENDED OPERATING CONDITION: (Ta=25 °C)

PARAMETER	SYMBOL	MIN.	TYP.	MAX.	UNIT
Supply Voltage	V _{DD}	1.5	-	3.3	V

C. ABSOLUTE MAXIMUM RATINGS:

1. Supply voltage: V_{DD}=5 V
2. Control voltage: V_{CTL}=5 V
3. Input power:
 - P_{IN} (inband): +10 dBm(V_{DD}=2.8 V, f=1575, 1597~1606, 1559~1591 MHz)
 - P_{IN} (outband): +25 dBm(V_{DD}=2.8 V, f=50~1460, 1710~4000 MHz)
4. Power dissipation: P_D=560 mW(4-layer FR4 PCB without through-hole(101.5x114.5 mm), T_j=100 °C)
5. Terminating source impedance: Z_s = 50 (Single-ended)
Terminating load impedance: Z_L = 50 (Single-ended)
6. Operating temperature range: -40 °C to +105 °C
7. Storage temperature range: -40 °C to +110 °C

D. FEATURES:

1. Available for GNSS.
2. Low supply voltage: 1.8/ 2.8 V typ.
3. Low current consumption:
 - 3.0/3.7mA typ. (at V_{DD}=1.8/ 2.8 V, V_{CTL}=1.8 V)
 - 0.1µA typ. (at V_{DD}=1.8/ 2.8 V, V_{CTL}=0 V (Stand-by mode))
4. High gain: 15.5/16.0dB typ. (at V_{DD}=1.8/2.8 V, V_{CTL}=1.8 V, f=1575 MHz, 1559~1591 MHz)
5. Low noise figure:
 - 1.55/1.50dB typ. (at V_{DD}=1.8/ 2.8 V, V_{CTL}=1.8 V, f=1575 MHz)

- 1.70/1.65dB typ. (at $V_{DD}=1.8/2.8$ V, $V_{CTL}=1.8$ V, $f=1597\sim 1606$ MHz)
- 1.75/1.70dB typ. (at $V_{DD}=1.8/2.8$ V, $V_{CTL}=1.8$ V, $f=1559\sim 1591$ MHz)

6. High out band rejection.

- 55 dBc typ. (at $f=704\sim 915$ MHz, relative to 1575 MHz)
- 43 dBc typ. (at $f=1710\sim 1980$ MHz, relative to 1575 MHz)
- 51 dBc typ. (at $f=2400\sim 2500$ MHz, relative to 1575 MHz)

7. Small package size: HFFP10-HH: 1.5mmx1.1mm (typ.), $t=0.5$ mm (max.)

8. Moisture Sensitivity Level: Level 1

E. ELECTRICAL CHARACTERISTICS 1 (DC):

(General conditions: $T_a=+25$ °C)

Parameter / Conditions		Symbol	Unit	Min.	Typ.	Max.
Supply Voltage		V_{DD}	V	1.5	-	3.3
Control Voltage (High)		$V_{CTL(H)}$	V	1.5	1.8	3.3
Control Voltage (Low)		$V_{CTL(L)}$	V	0	0	0.3
Supply Current 1	RF OFF, $V_{DD}=2.8$ V, $V_{CTL}=1.8$ V	I_{DD1}	mA	-	3.7	-
Supply Current 2	RF OFF, $V_{DD}=1.8$ V, $V_{CTL}=1.8$ V	I_{DD2}	mA	-	3.0	-
Supply Current 3	RF OFF, $V_{DD}=2.8$ V, $V_{CTL}=0$ V	I_{DD3}	μ A	-	0.1	5.0
Supply Current 4	RF OFF, $V_{DD}=1.8$ V, $V_{CTL}=0$ V	I_{DD4}	μ A	-	0.1	5.0
Control Current	$V_{CTL}=1.8$ V	I_{CTL}	μ A	-	5.0	15.0

F. ELECTRICAL CHARACTERISTICS 2 (RF):

(General conditions: $V_{DD}=2.8$ V, $V_{CTL}=1.8$ V, $f_{RF}=1575$ MHz, 1597~1606, 1559~1591 MHz, $T_a=+25$ °C, $Z_s=Z_l=50$ ohm, with application circuit)

Parameters Description		Symbol	Unit	Min.	Typ.	Max.
Small Signal Gain (GPS)1	$f=1575$ MHz (GPS) Exclude PCB, Connector Losses(0.17 dB)	GainGPS1	dB	-	16.0	-
Small Signal Gain (GLONASS)1	$f=1597\sim 1606$ MHz (GLONASS) Exclude PCB, Connector Losses(0.17 dB)	GainGLN1	dB	-	16.5	-
Small Signal Gain (BeiDou, Galileo)1	$f=1559\sim 1591$ MHz (BeiDou, Galileo) Exclude PCB, Connector Losses (0.17 dB)	GainBG1	dB	-	16.0	-
Noise Figure (GPS)1	$f=1575$ MHz (GPS)Exclude PCB, Connector Losses (0.09 dB)	NFGPS1	dB	-	1.50	-
Noise Figure (GLONASS)1	$f=1597\sim 1606$ MHz (GLONASS) Exclude PCB, Connector Losses (0.09 dB)	NFGLN1	dB	-	1.65	-
Noise Figure (BeiDou, Galileo)1	$f=1559\sim 1591$ MHz (BeiDou, Galileo) Exclude PCB, Connector Losses (0.09 dB)	NFBG1	dB	-	1.70	-
Input Power at 1dB Gain Compression Point 1	$f=1575, 1597$ to 1606, 1559 to 1591 MHz	P-1dB(IN)1	dBm	-	-10.0	-

Input 3rd Order Intercept Point 1	f1=1575, 1597 to 1606, 1559 to 1591 MHz, f2=f1 +/- 1 MHz, Pin=-30 dBm	IIP3_1	dBm	-	-2.0	-
Out of Band Input 2nd Order Intercept Point 1	f1=824.6 MHz at +15 dBm, f2=2400 MHz at +15 dBm, fmeas=1575.4 MHz	IIP2_OB1	dBm	-	+80	-
Out of Band Input 3rd Order Intercept Point 1	f1=1712.7 MHz at +15 dBm, f2=1850 MHz at +15 dBm, fmeas=1575.4 MHz	IIP3_OB1	dBm	-	+55	-
700 MHz Harmonic1	Input jammer tone: 787.76 MHz at +15 dBm Measure the harmonic tone at 1575.52 MHz	2fo1	dBm	-	-37	-
Out-of-Band Input Power 1dB Compression 1	fjam=900 MHz, fmeas=1575 MHz at Pin=-40 dBm	P-1dB(IN) _OB1-1	dBm	-	+24	-
	fjam=1710 MHz, fmeas=1575 MHz at Pin=-40 dBm	P-1dB(IN) _OB1-2	dBm	-	+24	-
Low Band Rejection 1	f=704 to 915 MHz, relative to 1575 MHz	BR_L1	dBc	-	55	-
High Band Rejection 1	f=1710 to 1980 MHz, relative to 1575 MHz	BR_H1	dBc	-	43	-
WLAN Band Rejection 1	f=2400 to 2500 MHz, relative to 1575 MHz	BR_W1	dBc	-	51	-
RF IN Return Loss (GPS)1	f=1575 MHz (GPS)	RLiGPS1	dB	-	10	-
RF IN Return Loss (GLONASS)1	f=1597 to 1606 MHz (GLONASS)	RLiGLN1	dB	-	15	-
RF IN Return Loss (BeiDou, Galileo)1	f=1559 to 1591 MHz (BeiDou, Galileo)	RLiBG1	dB	-	13	-
RF OUT Return Loss(GPS)1	f=1575 MHz (GPS)	RLoGPS1	dB	-	15	-
RF OUT Return Loss(GLONASS)1	f=1597 to 1606 MHz (GLONASS)	RLoGLN1	dB	-	15	-
RF OUT Return Loss(BeiDou, Galileo)1	f=1559 to 1591 MHz (BeiDou, Galileo)	RLoBG1	dB	-	15	-
Group Delay Time Deviation(GLONASS) 1	f=1597 to 1606 MHz (GLONASS)	GDTGLN1	ns	-	3	-
Group Delay Time Deviation(BeiDou)1	f=1559 to 1563.2 MHz (BeiDou)	GDTB1	ns	-	4	-
Group Delay Time Deviation(Galileo)1	f=1559 to 1591 MHz (Galileo)	GDTG1	ns	-	9	-

G. ELECTRICAL CHARACTERISTICS 3 (RF):

(General conditions: V_{DD}=1.8 V, V_{CTL}=1.8 V, f_{RF}=1575 MHz, 1597 to 1606, 1559 to 1591 MHz, T_a=+25 °C, Z_s=Z=50 ohm, with application circuit)

Parameters Description		Symbol	Unit	Min.	Typ.	Max.
Small Signal Gain (GPS)2	f=1575 MHz (GPS) Exclude PCB, Connector Losses (0.17 dB)	GainGPS2	dB	-	15.5	-
Small Signal Gain (GLONASS)2	f=1597 to 1606 MHz (GLONASS) Exclude PCB, Connector Losses (0.17 dB)	GainGLN2	dB	-	16.0	-

Small Signal Gain (BeiDou, Galileo) ²	f=1559 to 1591 MHz (BeiDou, Galileo) Exclude PCB, Connector Losses (0.17 dB)	GainBG2	dB	-	15.5	-
Noise Figure (GPS) ²	f=1575 MHz (GPS) Exclude PCB, Connector Losses (0.09 dB)	NFGPS2	dB	-	1.55	-
Noise Figure (GLONASS) ²	f=1597 to 1606 MHz (GLONASS) Exclude PCB, Connector Losses (0.09 dB)	NFGLN2	dB	-	1.70	-
Noise Figure (BeiDou, Galileo) ²	f=1559 to 1591 MHz (BeiDou, Galileo) Exclude PCB, Connector Losses (0.09 dB)	NFBG2	dB	-	1.75	-
Input Power at 1dB Gain Compression Point 2	f=1575, 1597 to 1606, 1559 to 1591 MHz	P-1dB(IN) ²	dBm	-	-13.0	-
Input 3rd Order Intercept Point 2	f1=1575, 1597 to 1606, 1559 to 1591 MHz, f2=f1 +/-1 MHz, Pin=-30 dBm	IIP3_2	dBm	-	-5.0	-
Out of Band Input 2nd Order Intercept Point 2	f1=824.6 MHz at +15 dBm, f2=2400 MHz at +15 dBm, fmeas=1575.4 MHz	IIP2_OB2	dBm	-	+80	-
Out of Band Input 3rd Order Intercept Point 2	f1=1712.7 MHz at +15 dBm, f2=1850 MHz at +15 dBm, fmeas=1575.4 MHz	IIP3_OB2	dBm	-	+55	-
700MHz Harmonic ²	Input jammer tone: 787.76 MHz at +15 dBm Measure the harmonic tone at 1575.52 MHz	2fo ²	dBm	-	-37	-
Out-of-Band Input Power 1dB Compression 2	fjam=900 MHz, fmeas=1575 MHz at Pin=-40 dBm	P-1dB(IN)_OB2-1	dBm	-	+24	-
	fjam=1710 MHz, fmeas=1575 MHz at Pin=-40 dBm	P-1dB(IN)_OB2-2	dBm	-	+24	-
Low Band Rejection 2	f=704 to 915 MHz, relative to 1575 MHz	BR_L2	dBc	-	55	-
High Band Rejection 2	f=1710 to 1980 MHz, relative to 1575 MHz	BR_H2	dBc	-	43	-
WLAN Band Rejection 2	f=2400 to 2500 MHz, relative to 1575 MHz	BR_W2	dBc	-	51	-
RF IN Return Loss (GPS) ²	f=1575 MHz (GPS)	RLiGPS2	dB	-	10	-
RF IN Return Loss (GLONASS) ²	f=1597 to 1606 MHz (GLONASS)	RLiGLN2	dB	-	15	-
RF IN Return Loss (BeiDou, Galileo) ²	f=1559 to 1591 MHz (BeiDou, Galileo)	RLiBG2	dB	-	13	-
RF OUT Return Loss(GPS) ²	f=1575 MHz (GPS)	RLoGPS2	dB	-	15	-
RF OUT Return Loss(GLONASS) ²	f=1597 to 1606 MHz (GLONASS)	RLoGLN2	dB	-	15	-
RF OUT Return Loss(BeiDou, Galileo) ²	f=1559 to 1591 MHz (BeiDou, Galileo)	RLoBG2	dB	-	15	-
Group Delay Time Deviation(GLONASS) 2	f=1597 to 1606 MHz (GLONASS)	GDTGLN2	ns	-	3	-
Group Delay Time Deviation(BeiDou) ²	f=1559 to 1563.2 MHz (BeiDou)	GDTB2	ns	-	4	-
Group Delay Time Deviation (Galileo) ²	f=1559 to 1591 MHz (Galileo)	GDTG2	ns	-	9	-

H. FREQUENCY CHARACTERISTICS 1:

(Conditions: $V_{DD}=2.8$ V, $V_{CTL}=1.8$ V, $T_a=25$ °C, $Z_s=Z_l=50$ ohm, with application circuit.)

Transfer function:

S21 response (span: 250 MHz)

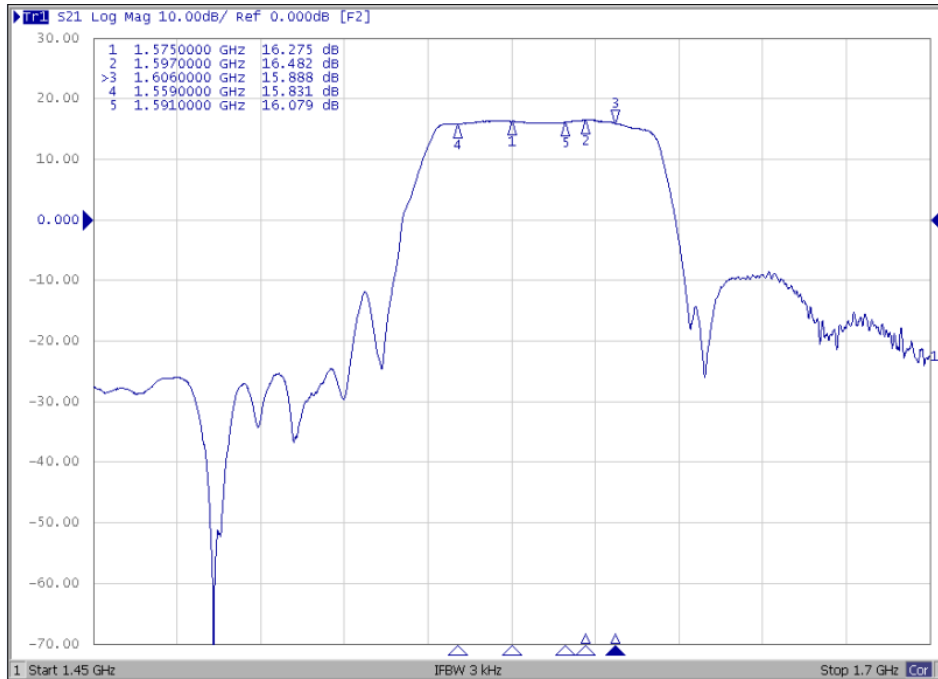

S21 response

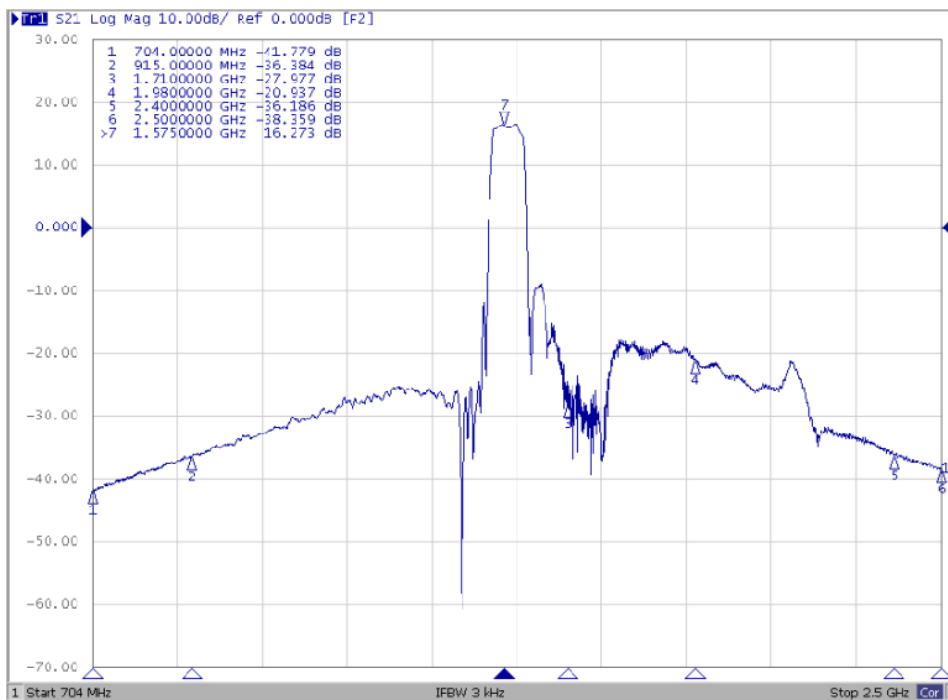

Group Delay

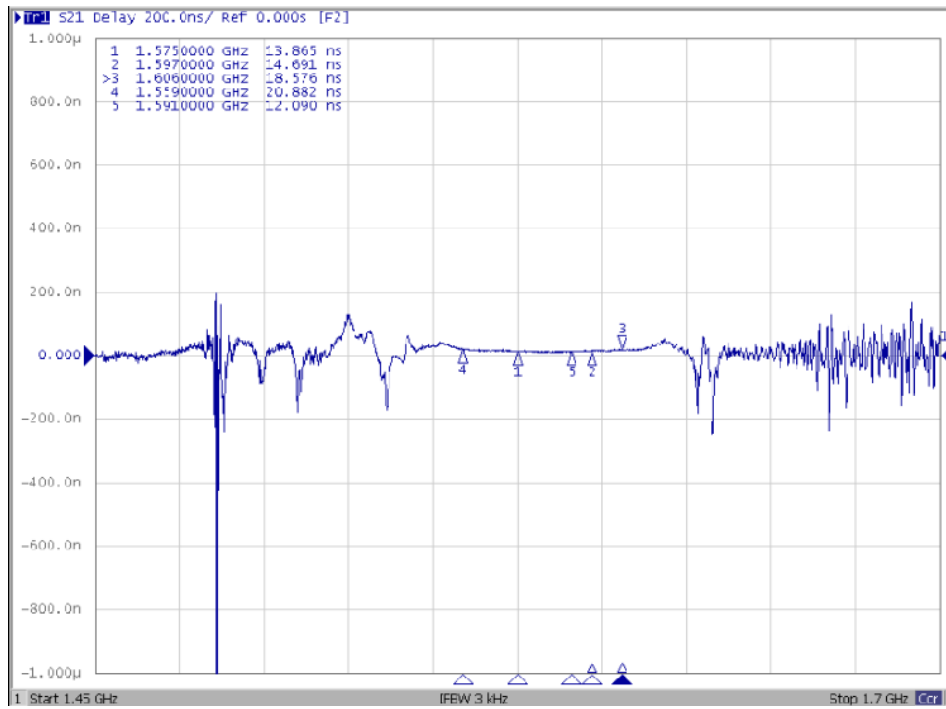

Reflection functions:

S11 VSWR

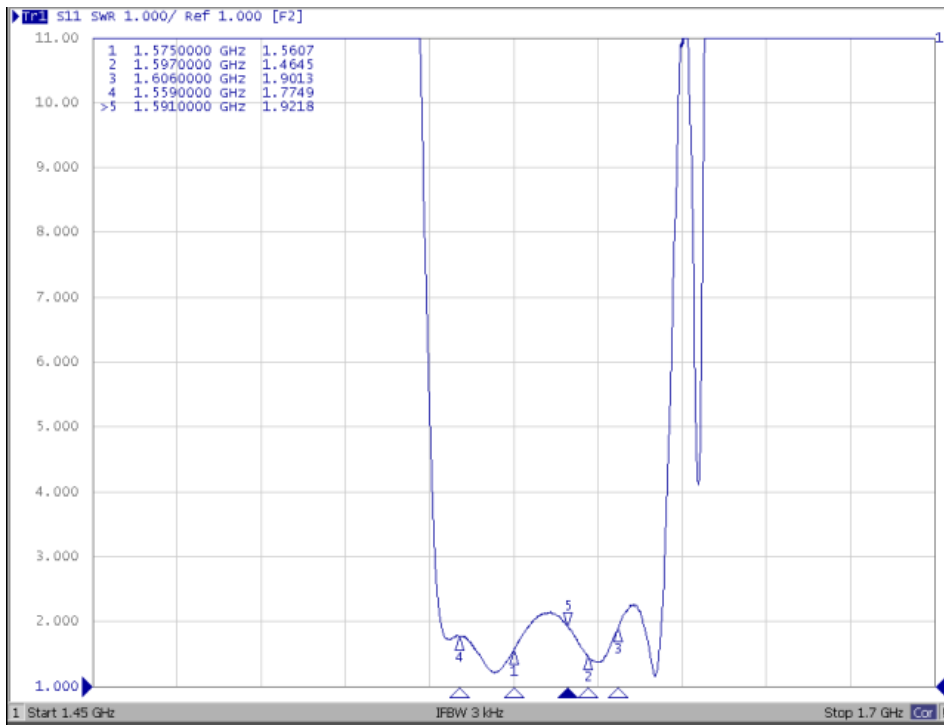

S22 VSWR

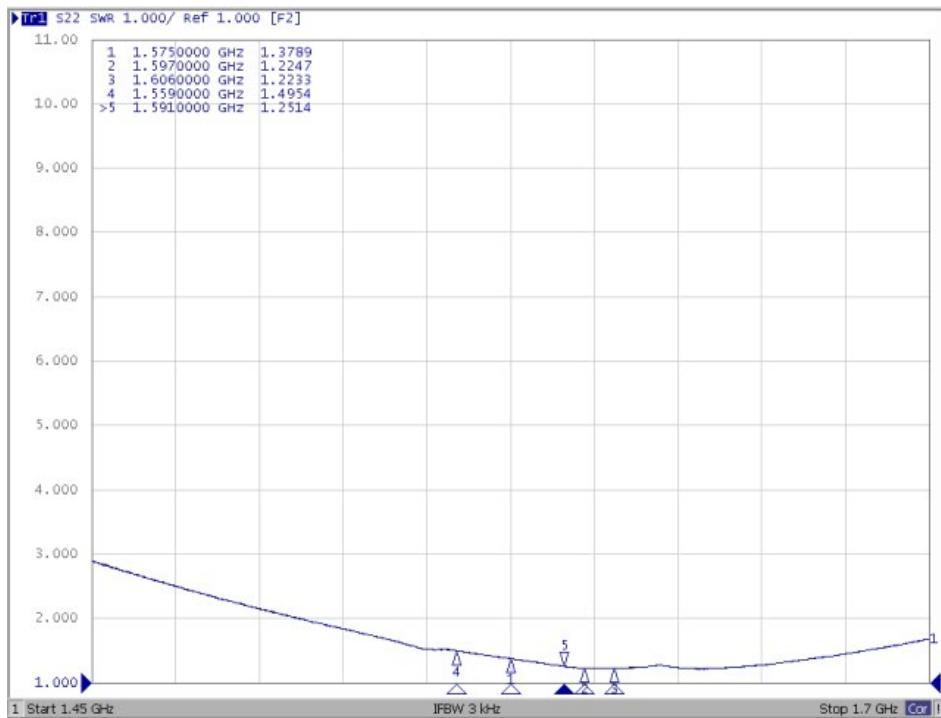

S11 Smith Chart

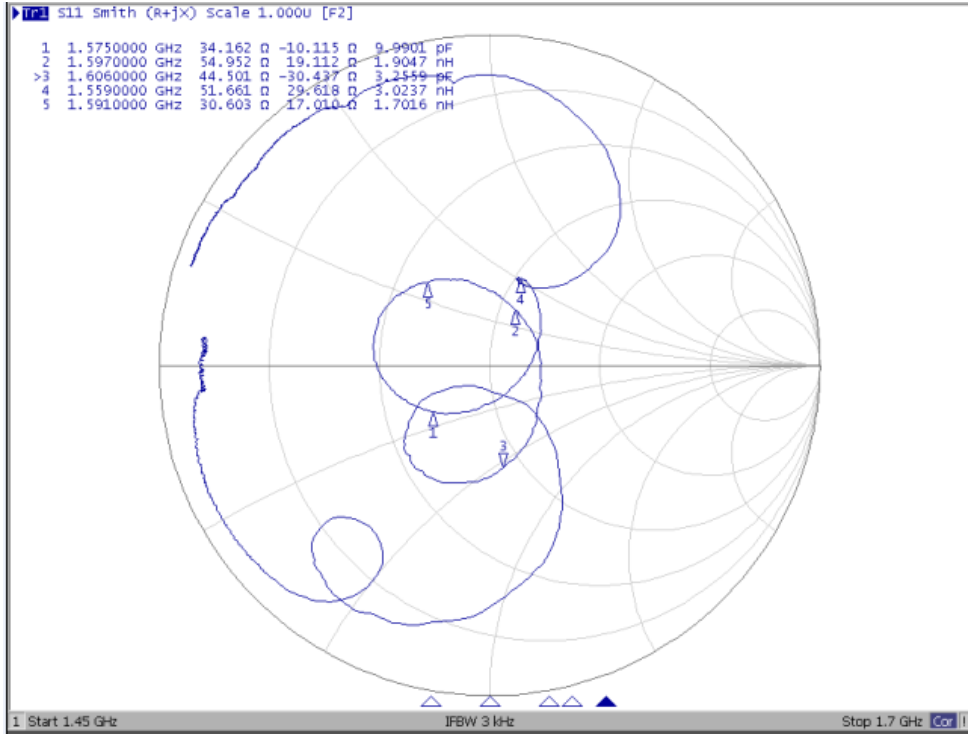

S22 Smith Chart

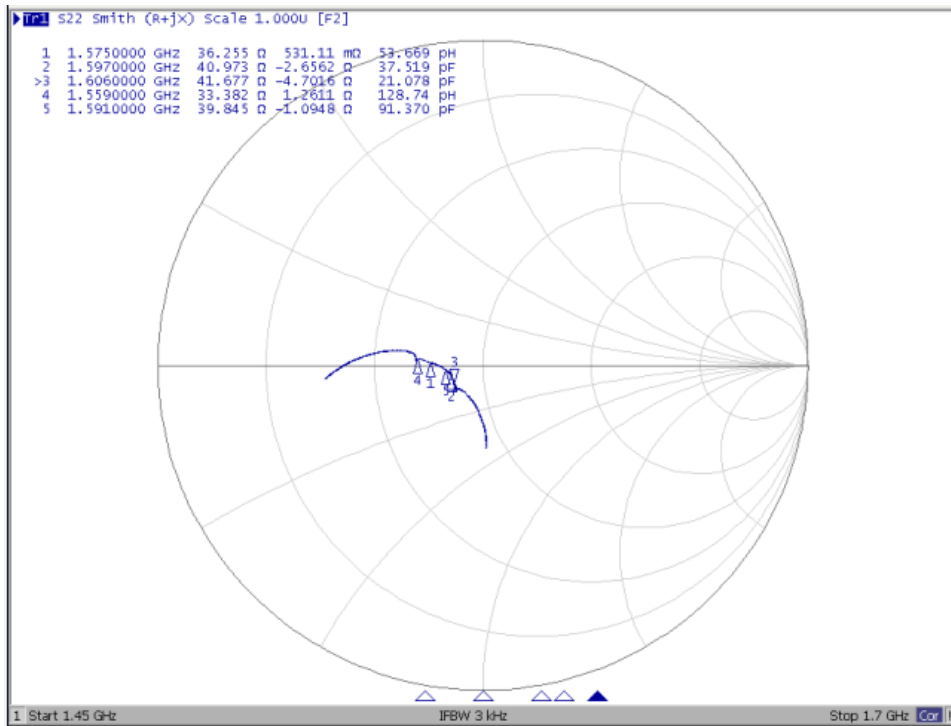

S11 Return Loss

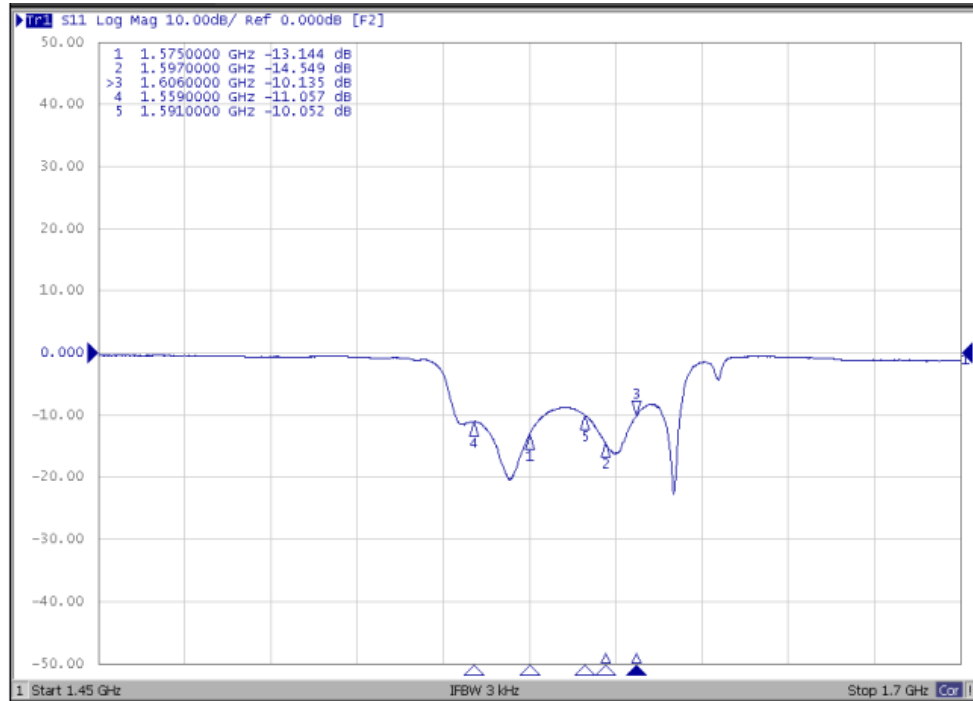

S11 Return Loss

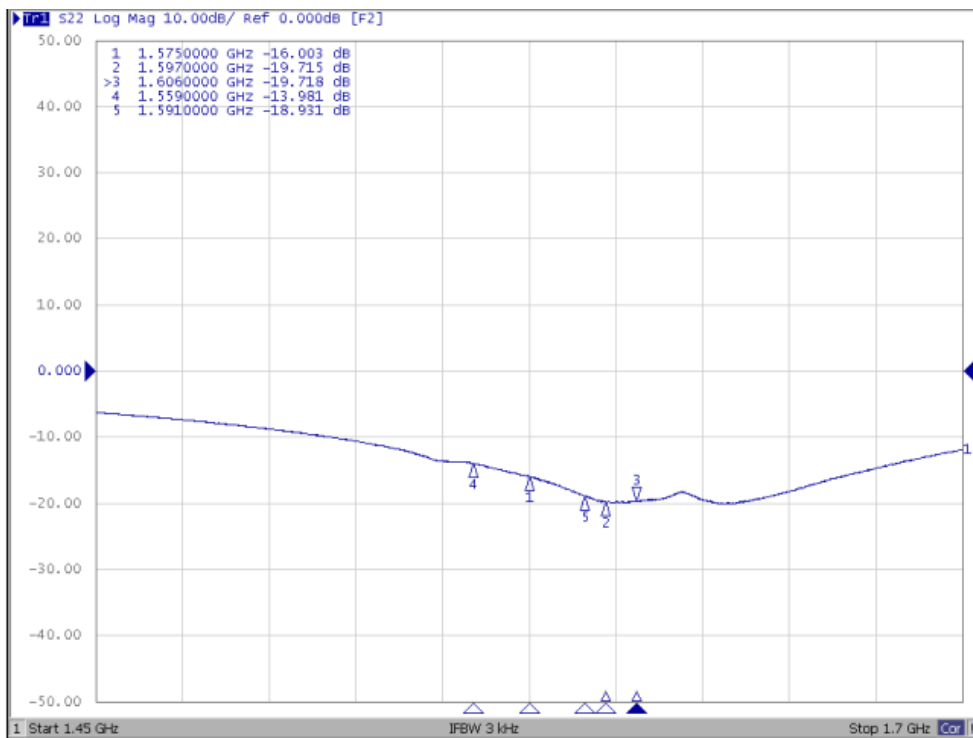

I. FREQUENCY CHARACTERISTICS 2:

(Conditions: $V_{DD}=1.8V$, $V_{CTL}=1.8V$, $T_a=25^{\circ}C$, $Z_s=Z_l=50\text{ ohm}$, with application circuit.)

Transfer function:

S21 response (span: 250 MHz)

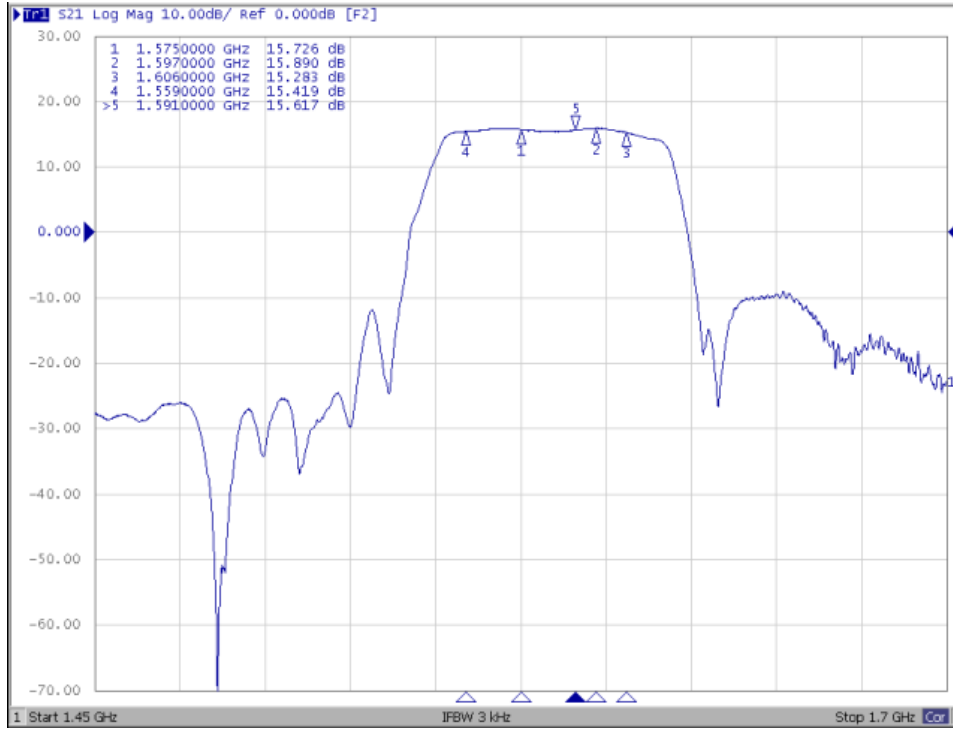

S21 response

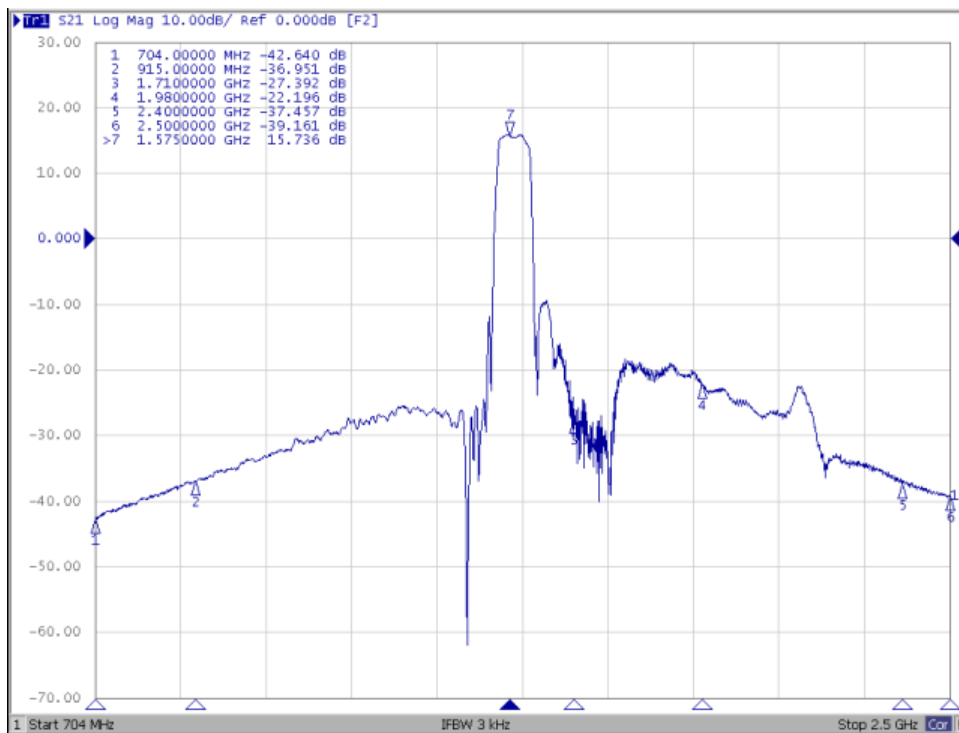

Group Delay

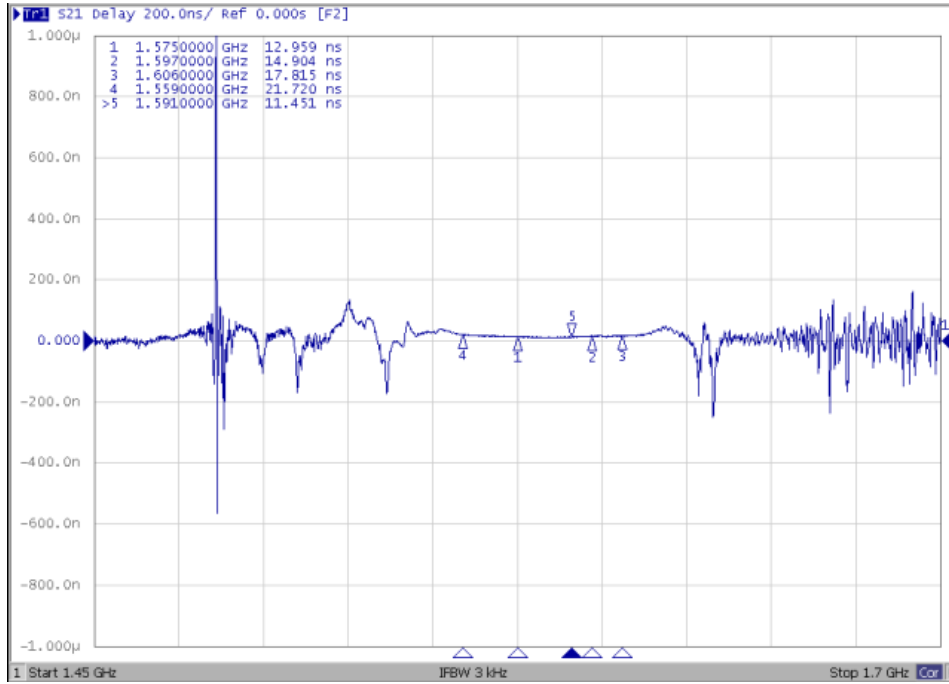

Reflection functions:

S11 VSWR

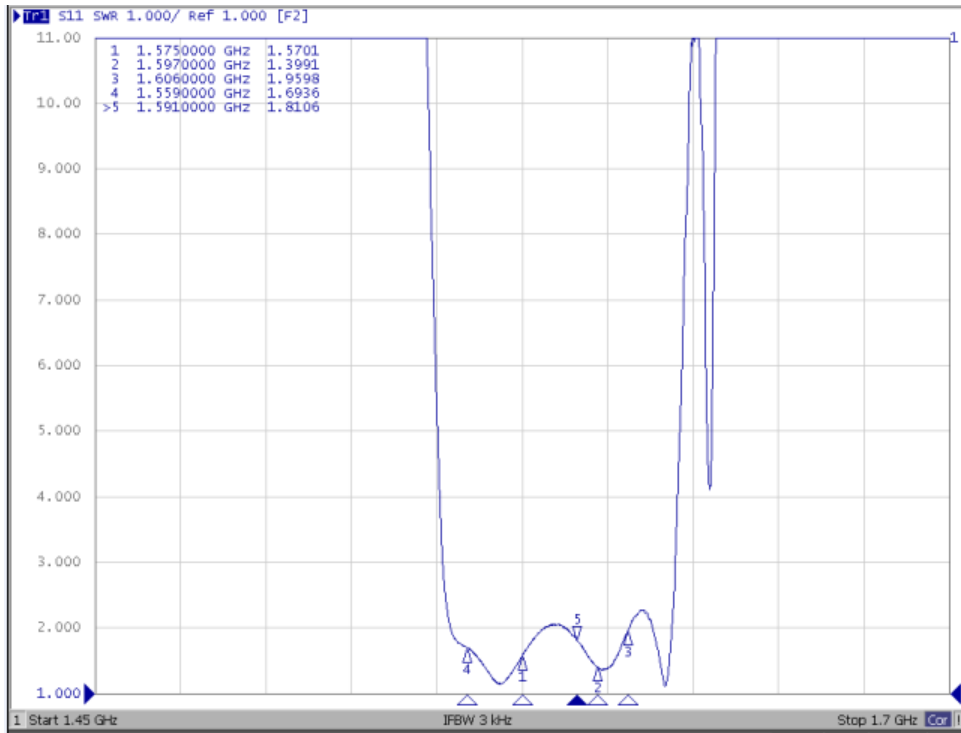

S22 VSWR

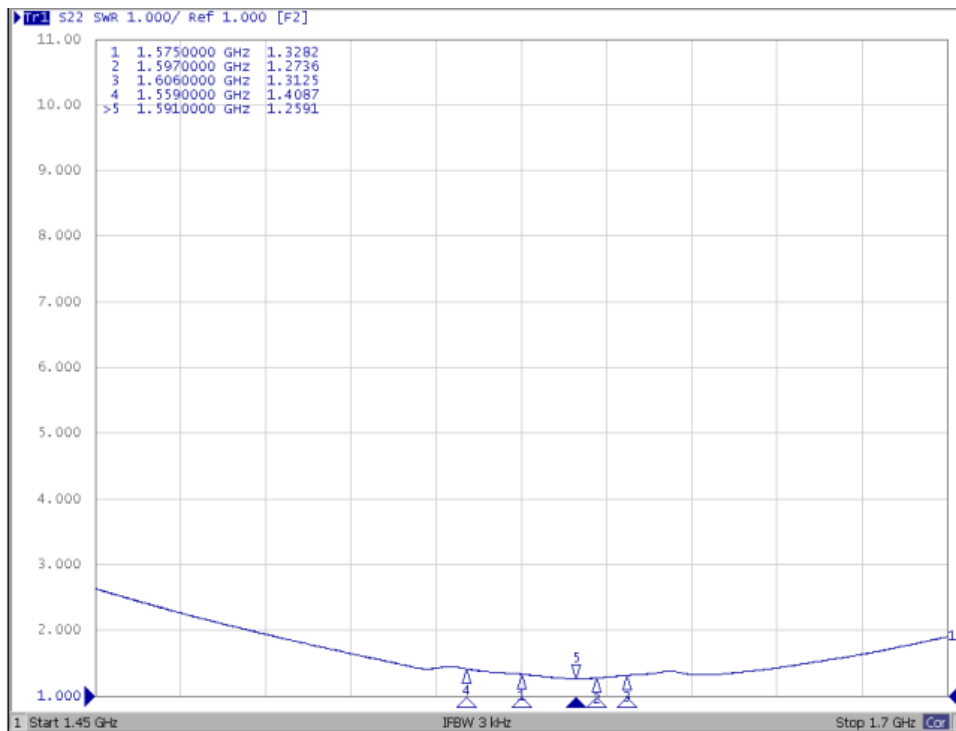

S11 Smith Chart

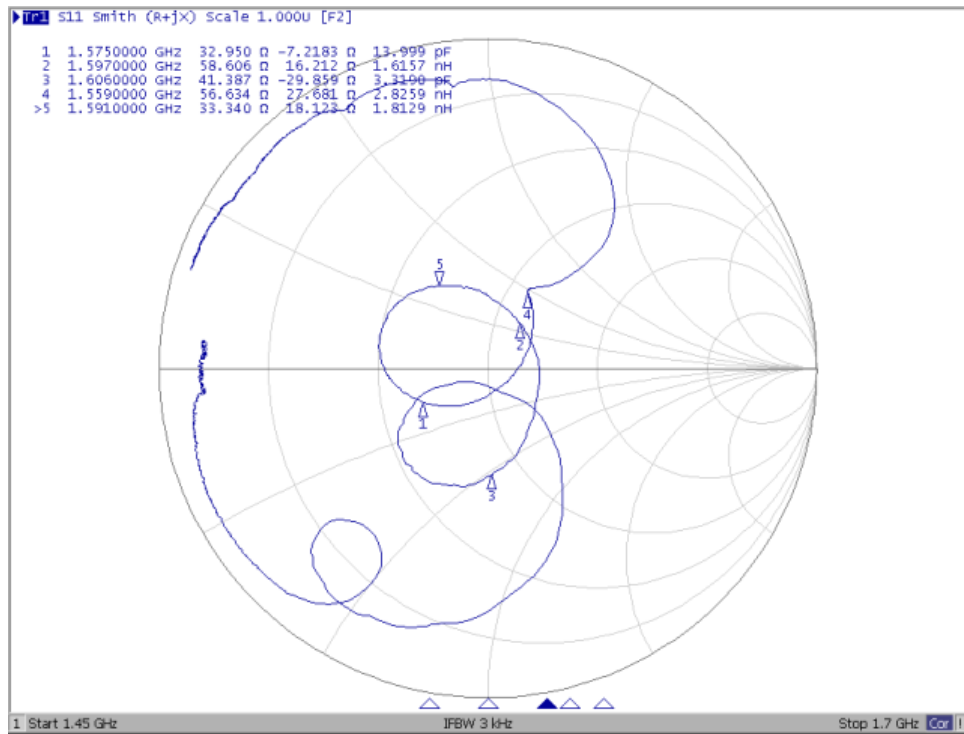

S22 Smith Chart

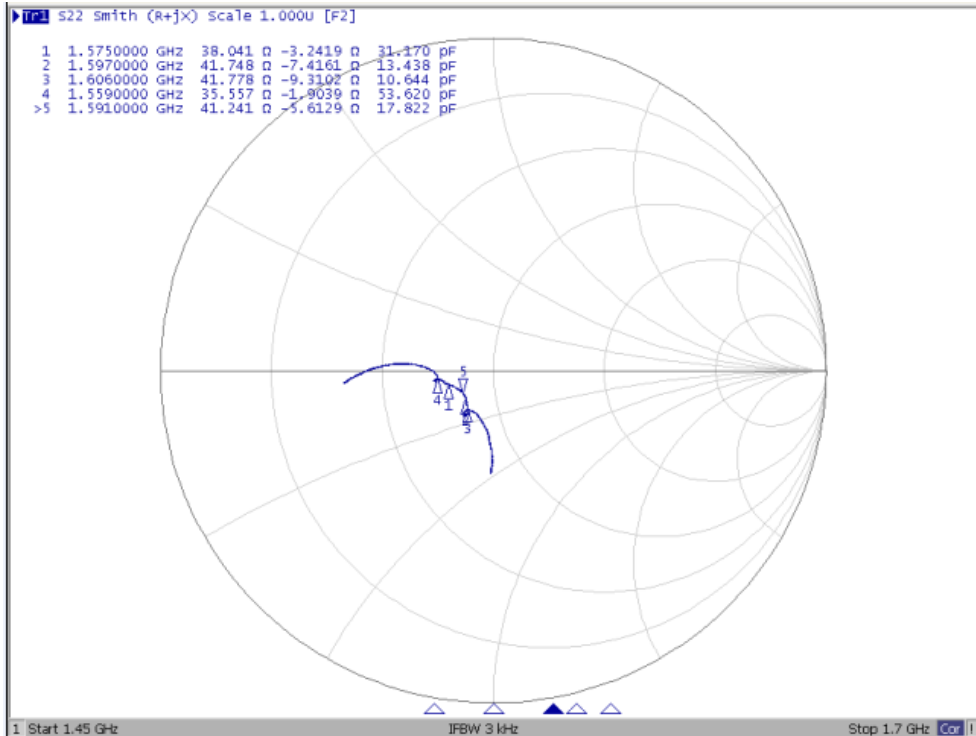

S11 Return Loss

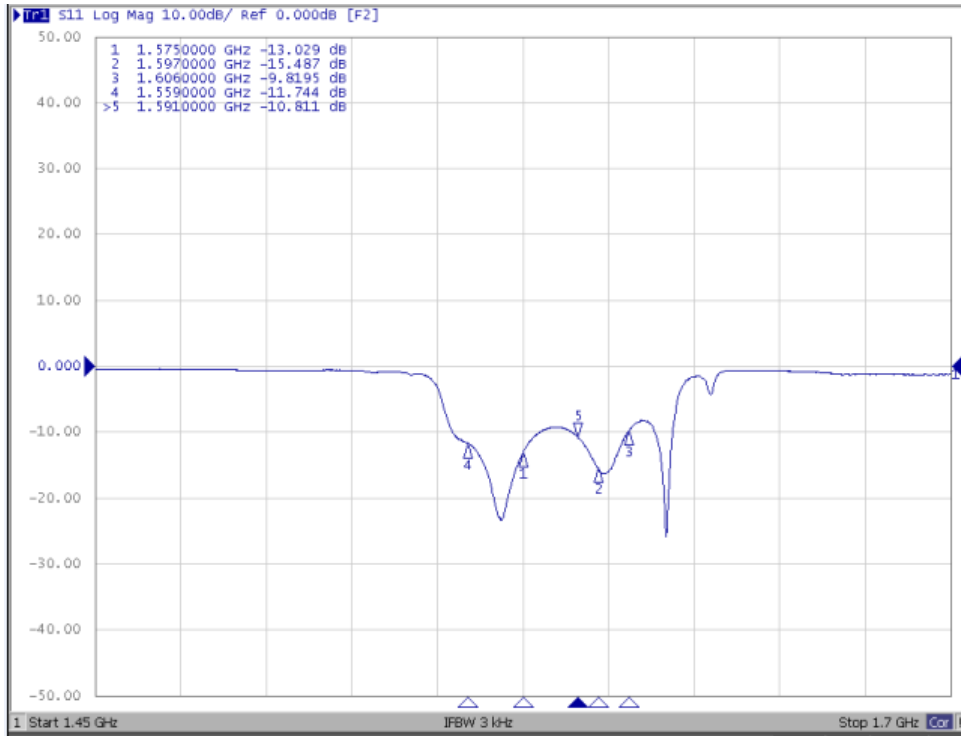

S22 Return Loss

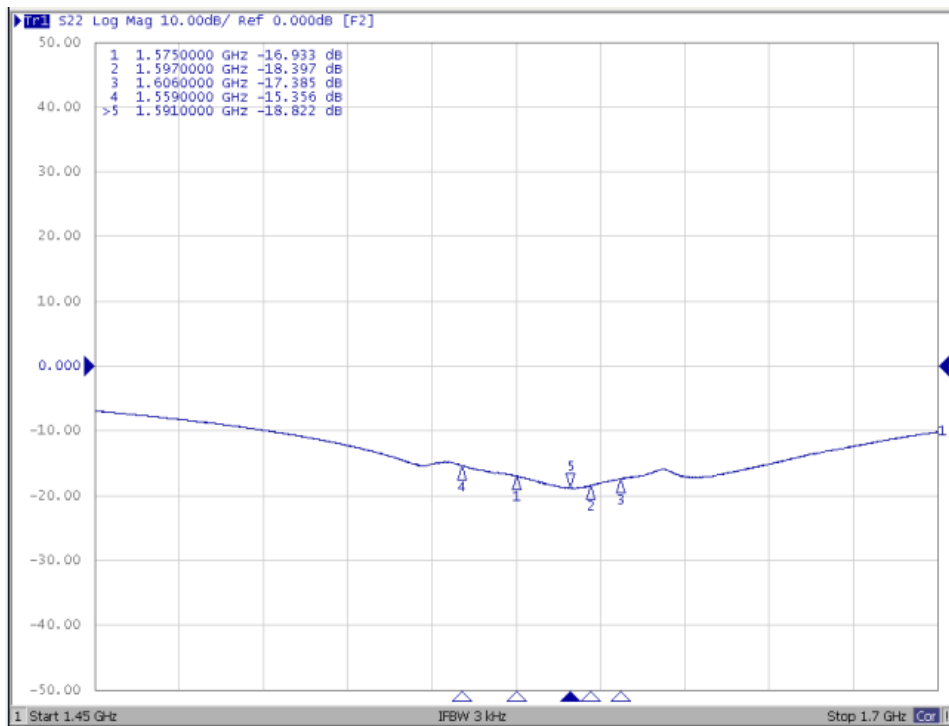

J. MEASUREMENT CIRCUIT:

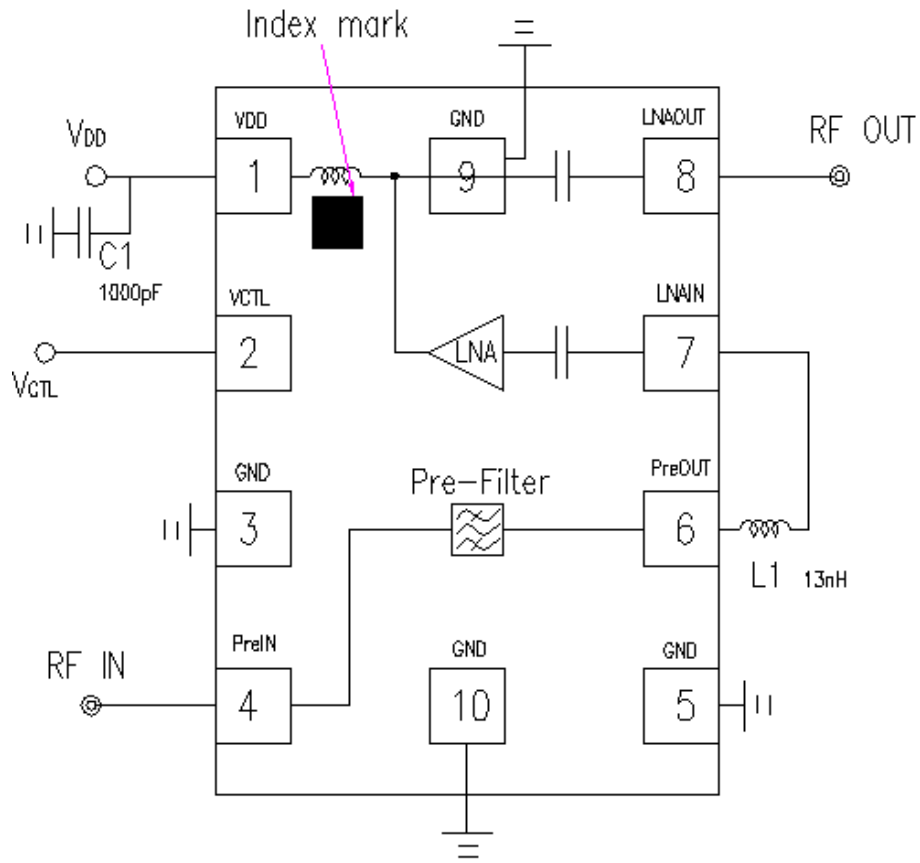

Top View

Parts list

Parts ID	Manufacture
L1	LQW15A Series (MURATA)
C1	GRM03 Series (MURATA)

K. PACKAGE OUTLINE:

UNIT: mm

Top View

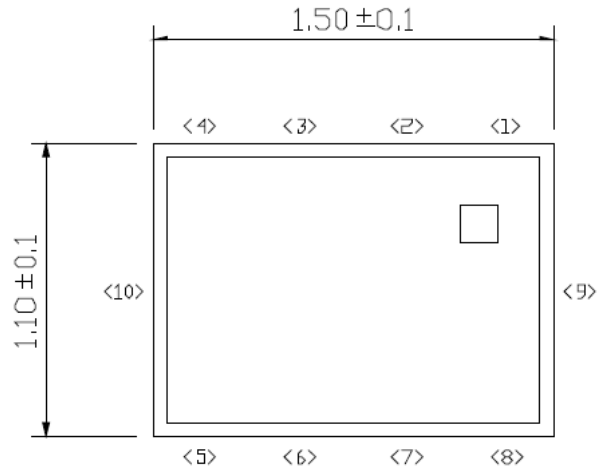

Side View

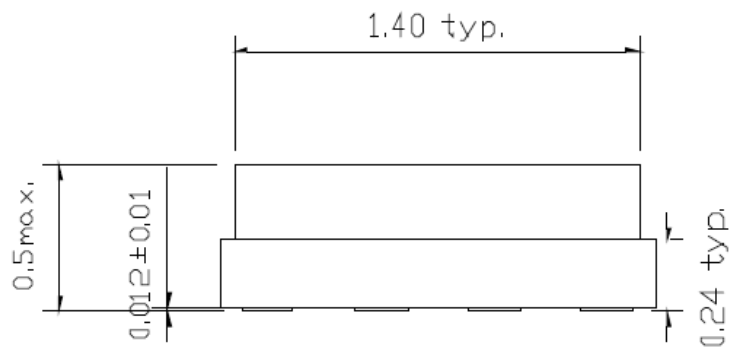

Bottom View

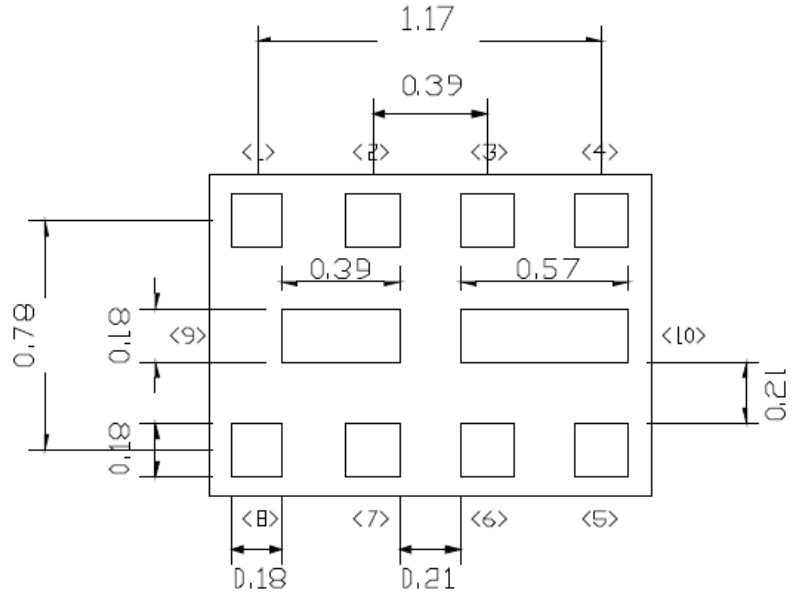

Electrode Dimensions clearance: ± 0.05 mm

Stand-off: 0.1 mm max.

Substrate: Ceramic

Terminal treat: Au

Lid: SnAg/Kovar/Ni

Weight (typ.): 5 mg

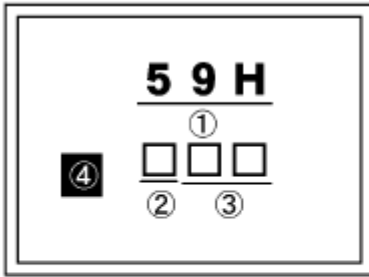

- ① Device No. (59H)
- ② Year-Month of manufacture

Year	Jan	Feb	Mar	Apr	May	Jun	Jul	Aug	Sep	Oct	Nov	Dec
2019 / 2023	a	b	c	d	e	f	g	h	j	k	l	m
2020 / 2024	n	p	q	r	s	t	u	v	w	x	y	z
2021 / 2025	A	B	C	D	E	F	G	H	J	K	L	M
2022 / 2026	N	P	Q	R	S	T	U	V	W	X	Y	Z

- ③ Lot No.
 - ④ Index Mark
-

L. PIN CONFIGURATION:

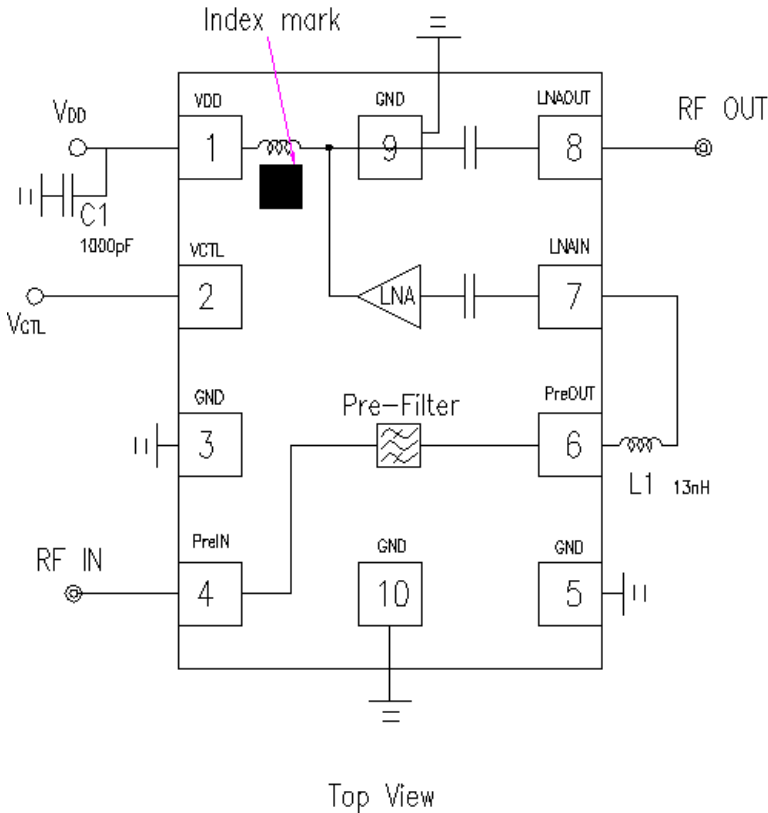

TRUTH TABLE

"H"= $V_{CTL}(H)$, "L"= $V_{CTL}(L)$

VCTL	Mode
H	Active mode
L	Stand-by mode

No.	SYMBOL	DESCRIPTION
1	VDD	Supply voltage terminal. Please connect bypass capacitor C1 with ground as close as possible.
2	VCTL	Control voltage terminal.
3	GND	Ground terminal. This terminal should be connected to the ground plane as close as possible for excellent RF performance.
4	PreIN	RF input terminal. This terminal connects to input of pre-SAW filter.
5	GND	Ground terminal. This terminal should be connected to the ground plane as close as possible for excellent RF performance.
6	PreOUT	Pre-SAW filter output terminal. This terminal connects to LNAIN with L1.
7	LNAIN	RF input terminal. This terminal requires only a matching inductor L1, and does not require DC blocking capacitor because of integrated capacitor.
8	LNAOUT	RF output terminal. This terminal requires no DC blocking capacitor since this terminal has integrated DC blocking capacitor.
9	GND	Ground terminal. This terminal should be connected to the ground plane as close as possible for excellent RF performance.
10	GND	Ground terminal. This terminal should be connected to the ground plane as close as possible for excellent RF performance.



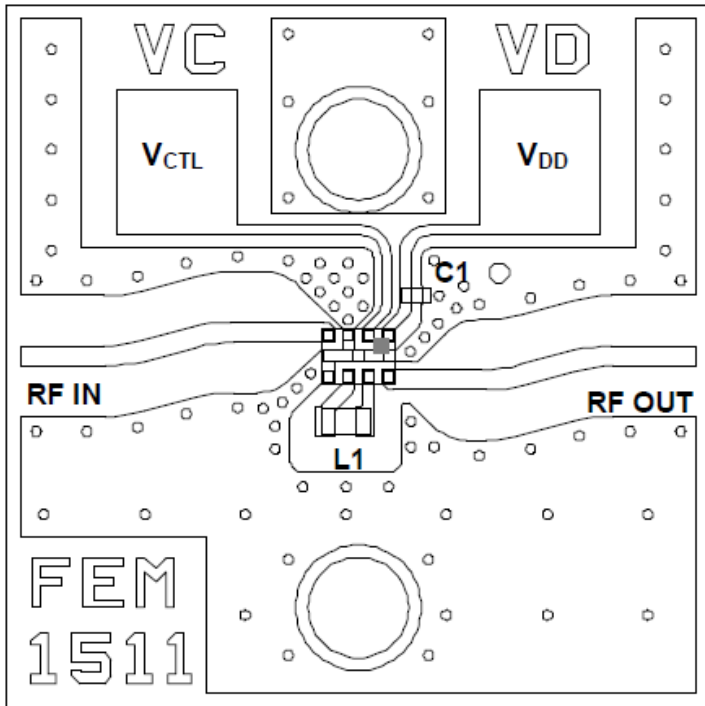

M. EVALUATION BOARD:

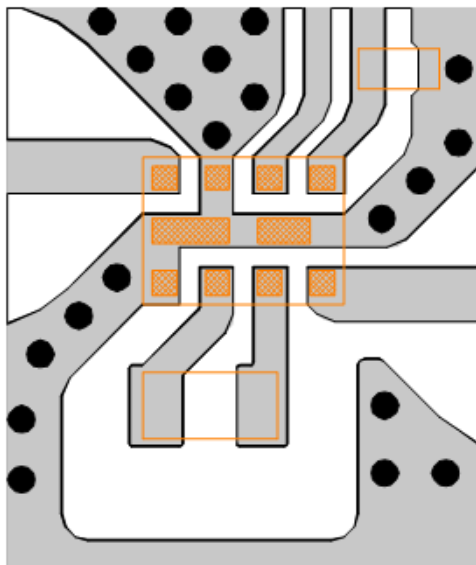

PCB
 Substrate: FR-4
 Thickness: 0.2 mm
 Microstrip line width: 0.4 mm($Z_0=50 \Omega$)
 Size: 14.0 mm x 14.0 mm

<PCB LAYOUT GUIDELINE>



 PCB
 PKG Terminal
 PKG Outline
 GND Via Hole
 Diameter $\square\square = 0.2 \text{ mm}$

PRECAUTIONS

- Please layout ground pattern under this FEM in order not to couple with RFIN and RFOUT terminal.
- All external parts should be placed as close as possible to the FEM.
- For good RF performance, all GND terminals must be connected to PCB ground plane of substrate, and via-holes for GND should be placed near the FEM.

N. RECOMMENDED FOOTPRINT PATTERN:

PKG: 1.5 mm x 1.1 mm

Pin pitch: 0.39 mm

 : Land

 : Mask (Open area) *Metal mask thickness: 100 μm

 : Resist (Open area)

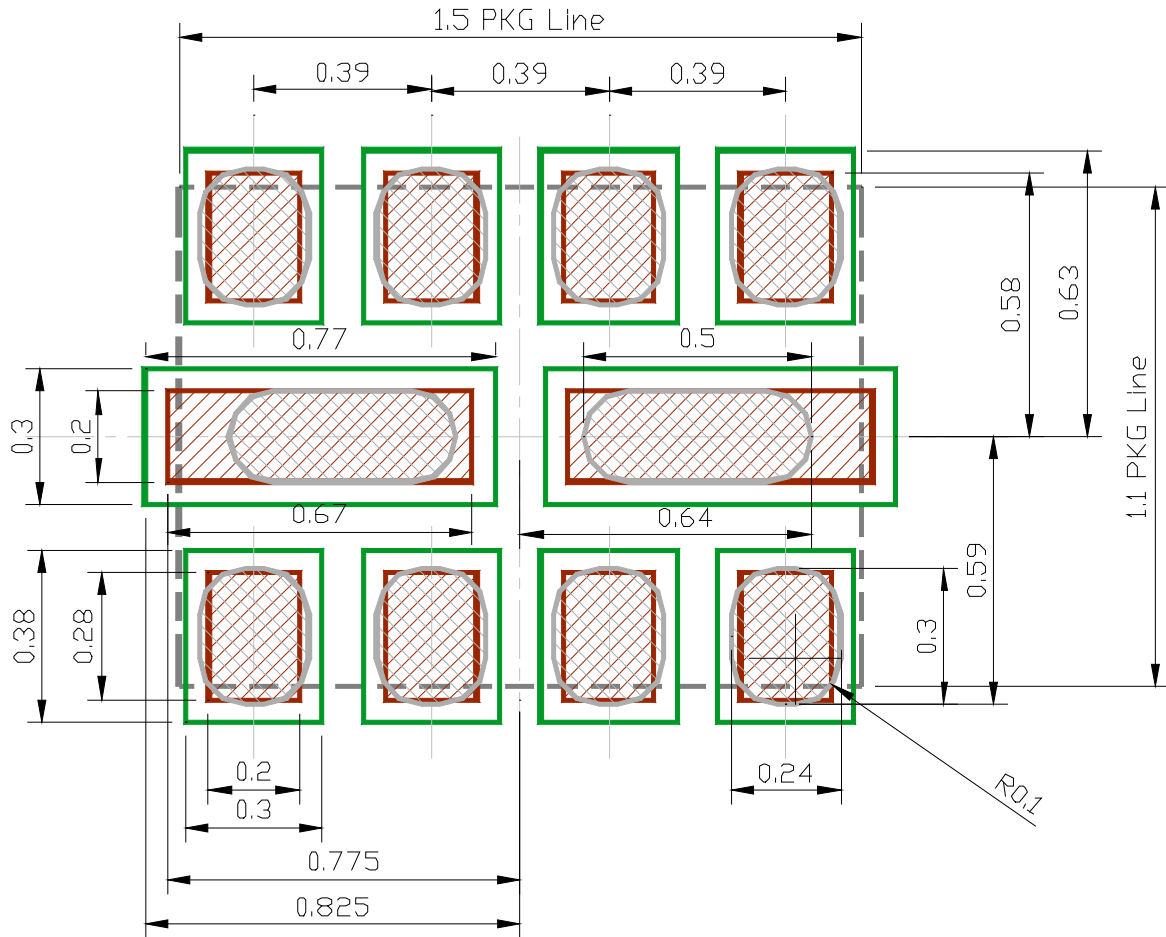

O. PACKING SPECIFICATION:

【TAPING DIMENSION】

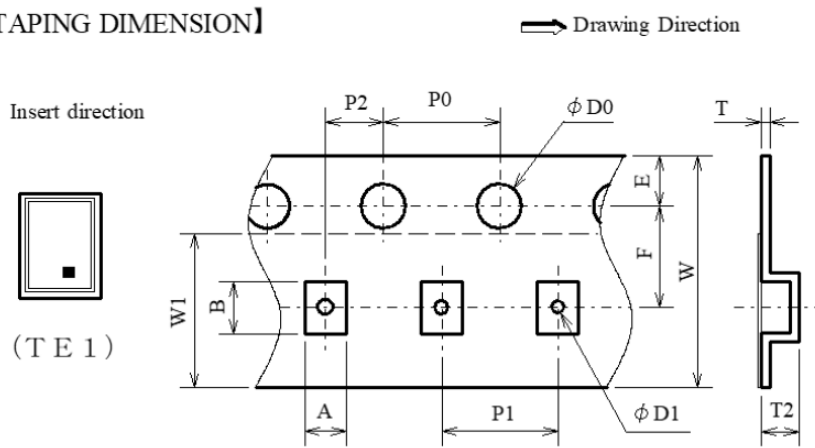

SYMBOL	DIMENSION	REMARKS
A	1.5±0.1	BOTTOM DIMENSION
B	1.85±0.1	BOTTOM DIMENSION
D0	1.5 ^{+0.1} ₀	
D1	0.5±0.05	
E	1.75±0.1	
F	3.5±0.05	
P0	4.0±0.1	
P1	4.0±0.1	
P2	2.0±0.05	
T	0.25±0.05	
T2	0.7±0.1	
W	8.0±0.2	
W1	5.3±0.2	THICKNESS 100 μm max

Carrier tape material: PS (Anti-static)
Cover tape material: PET (Anti-static)

【REEL DIMENSION】

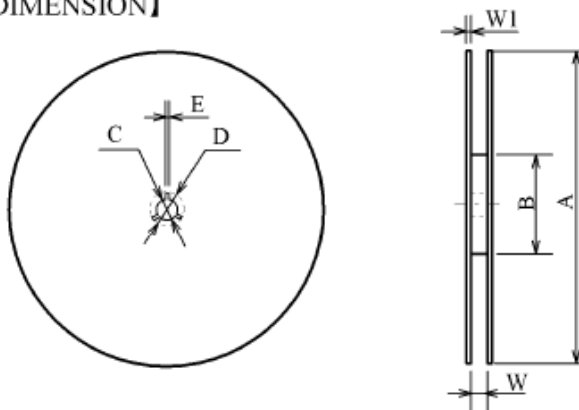

SYMBOL	DIMENSION
A	φ 180 ⁺⁰ _{-1.5}
B	φ 66±0.5
C	φ 13±0.2
D	φ 21±0.8
E	2±0.5
W	9 ^{+1.0} ₋₀
W1	1.2

*MATERIAL : PS carbon (Anti-static)

【TAPING STATE】

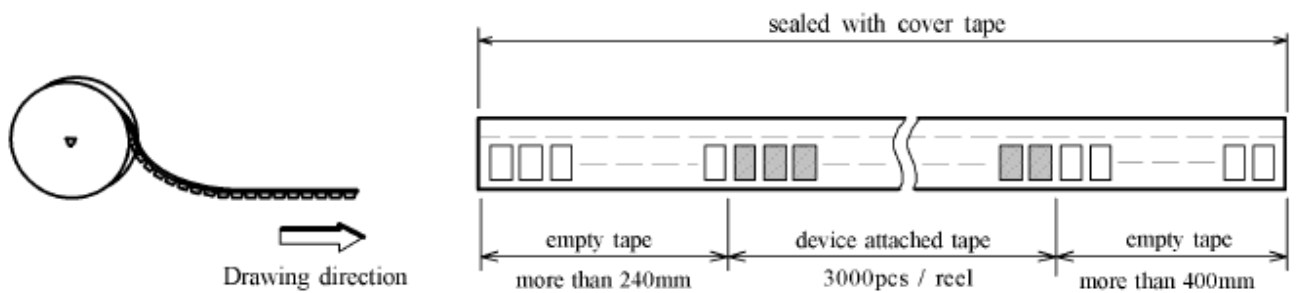

P. RECOMMENDED REFLOW PROFILE:

* Recommended reflow soldering procedure

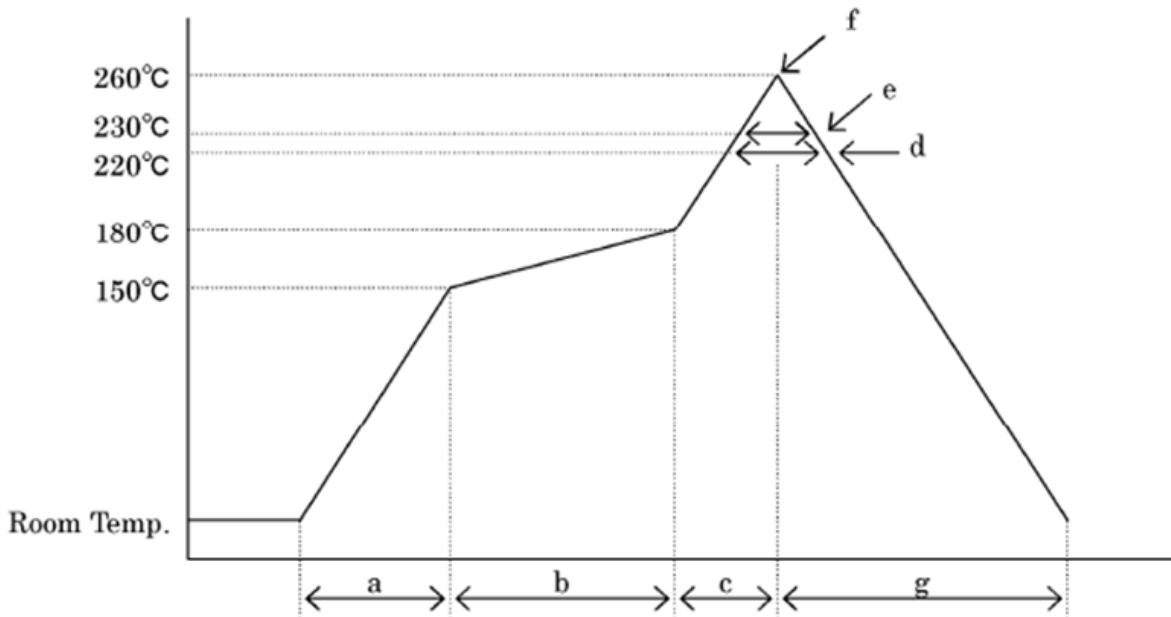

- | | |
|-----------------------------|------------------|
| a. Temperature ramping rate | 1 to 4°C/s |
| b. Pre-heating temperature | 150 to 180°C |
| time | 60 to 120s |
| c. Temperature ramp rate | 1 to 4°C/s |
| d. 220°C or higher time | Shorter than 60s |
| e. 230°C or higher time | Shorter than 40s |
| f. Peak temperature | Lower than 260°C |
| g. Temperature ramping rate | 1 to 6°C/s |

The temperature indicates at the surface of mold package

<p>Cautions on using this product</p> <p>This product contains Gallium-Arsenide (GaAs) which is a harmful material.</p> <ul style="list-style-type: none"> • Do NOT eat or put into mouth. • Do NOT dispose in fire or break up this product. • Do NOT chemically make gas or powder with this product. • To waste this product, please obey the relating law of your country.
<p>This product may be damaged with electric static discharge (ESD) or spike voltage. Please handle with care to avoid these damages.</p>