

SAFDC314MSQ1T91R05

**314.350 MHz
SAW Filter**

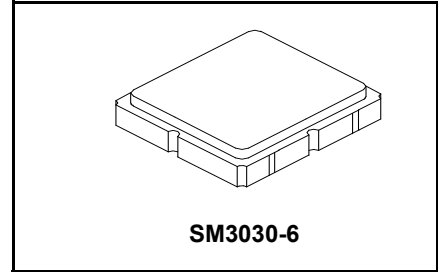

1. Scope

This delivery specification specifies SAFDC314MSQ1T91R05, a 300MHz band surface wave filter used for communication equipment. Please contact us in advance if you use it for any other purpose.

- Country of Origin: Taiwan
- AEC-Q200 Qualified

2. Customer Number if Applicable

Customer PN:		Customer drawing number	
--------------	--	-------------------------	--

3. RFMi Part Number

SAFDC314MSQ1T91R05	Tape/Packing (5000 pcs)
--------------------	-------------------------

4. Dimensions

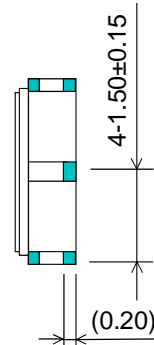
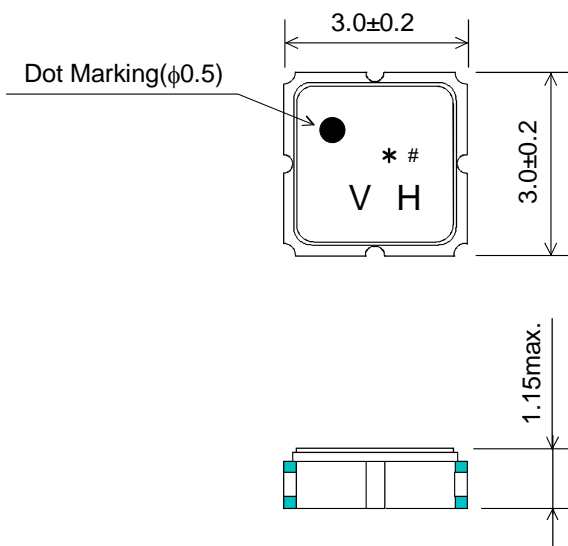

Marking : Laser Printing

* (EIAJ Code)
 # Manufacturing Week
 Week 1
 Week 2

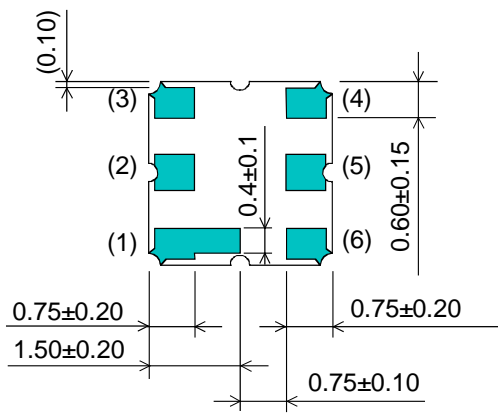

Week 6
 Terminal (Surface): Gold
 0.3~1.0 μ m
 (Typ.0.6 μ m)
 Thickness 2.0~8.0 μ m
 (Typ.3.5 μ m)

(2) : input
 (5) : output
 Others : Ground (case)

Weight : 32±5mg

Coplanarity : 0.1mm max.

Unit : mm

4.1 Diagram

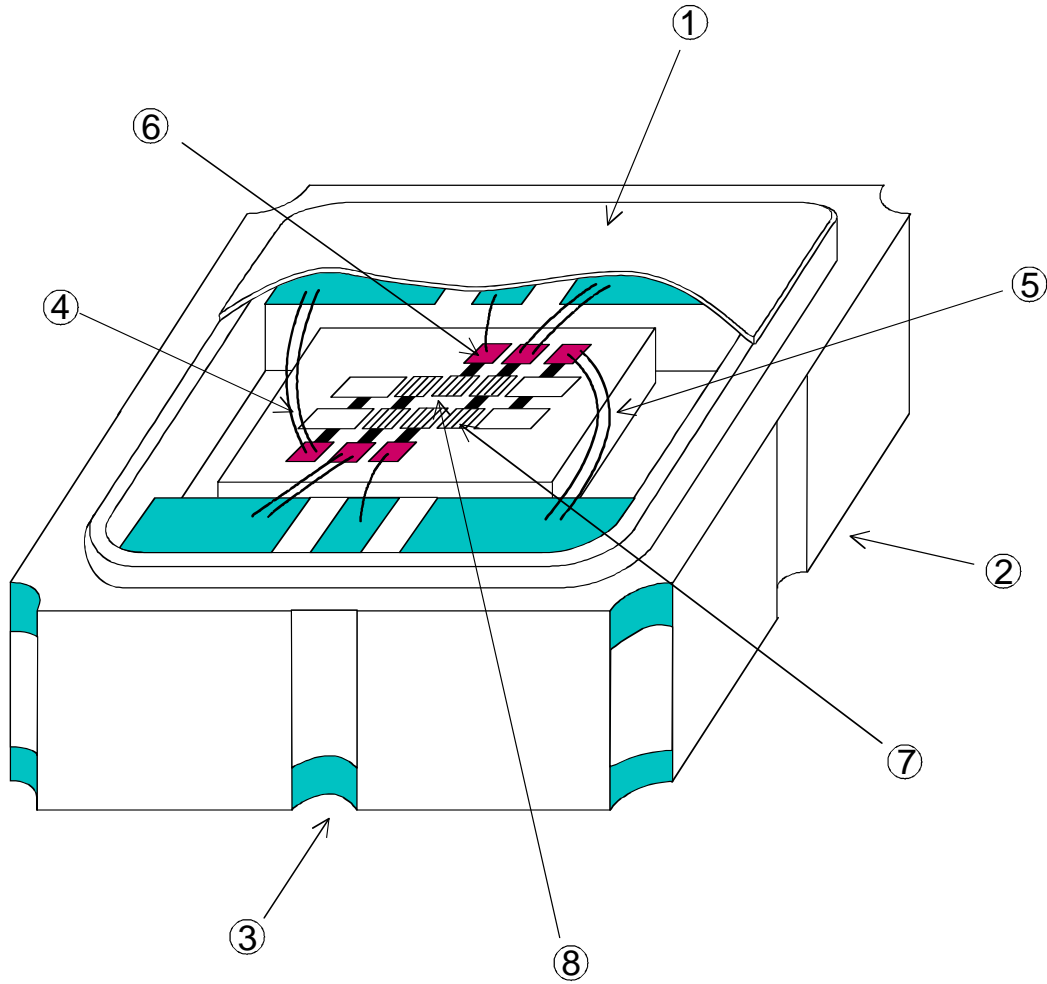

	Product Name	Material
①	Metal lid	Kovar, Ni plating
②	Multilayer ceramic	Alumina
③	Terminal	Au plating
④	Bonding wire	Al
⑤	Piezoelectric substrate	LiTaO3
⑥	Wire bonding pad	Al/Cu
⑦	I D T (Interdigital transducer)	Al/Cu
⑧	Protective film	SiO2

5. Maximum Ratings

5.1	Withstanding voltage for short term between the terminals	Maximum allowable voltage 10V (Insulation resistance 10MΩ or more, 25 ± 2 °C)
5.2	D. C. Voltage between the terminals	Maximum allowable capacity 3V (25 ± 2 °C)
5.3	Allowable input level	1)1 minute at 30mW (+ 14.8dBm) 2)1000 hours at 20mW (+ 13dBm)
5.4	Operating Temperature	-40~+110°C
5.5	Storage Temperature	-40~+110°C

6. Electrical performance

6.1 -40~+110°C

	Item	Specifications	Room temperature ability (reference value)
6.1.1	Nominal center frequency (fc)	314.35 MHz	
6.1.2	Insertion Loss		
	1) Within 313.85 ~ 314.85 MHz (Pass bandwidth)	2.5 dB min	1.7 dB
	2) 10 ~ 270 MHz	55 dB max	70 dB
	3) 270 ~ 290 MHz	50 dB max	60 dB
	4) 290 ~ 295 MHz	50 dB max	58 dB
	5) 300 ~ 305 MHz	35 dB max	45 dB
	6) 308.85 ~ 309.35 MHz	32 dB max	47 dB
	7) 309.35 ~ 309.85 MHz	25 dB max	42 dB
	8) 324 ~ 330 MHz	27 dB max	31 dB
	9) 335 ~ 340 MHz	40 dB max	56 dB
	10) 350 ~ 650 MHz	40 dB max	54 dB
	11) 650 ~ 1000 MHz	23 dB max	44 dB
6.1.3	Ripple deviation (within 313.85-314.85MHz)	1.5 dB min	0.3 dB
6.1.4	VSWR (within 313.85-314.85MHz)	3.0 min	1.5

6.2 -40~+85°C

	Item	Specifications	Room temperature ability (reference value)
6.2.1	Nominal center frequency (fc)	314.35 MHz	
6.2.2	Insertion loss 1) 313.85 ~ 314.85 MHz (Pass bandwidth) 2) 10 ~ 270 MHz 3) 270 ~ 290 MHz 4) 290 ~ 295 MHz 5) 300 ~ 305 MHz 6) 308.85 ~ 309.35 MHz 7) 309.35 ~ 309.85 MHz 8) 324 ~ 330 MHz 9) 335 ~ 340 MHz 10) 350 ~ 650 MHz 11) 650 ~ 1000 MHz	2.5 dB min 55 dB max 50 dB max 50 dB max 35 dB max 35 dB max 27 dB max 27 dB max 40 dB max 40 dB max 23 dB max	1.7 dB 70 dB 60 dB 58 dB 45 dB 47 dB 42 dB 31 dB 56 dB 54 dB 44 dB
6.2.3	Ripple deviation (within 313.85-314.85MHz)	1.5 dB min	0.3 dB
6.2.4	VSWR (within 313.85-314.85MHz)	2.5 min	1.5

6.3 25±2°C

	Item	Specifications	Room temperature ability (reference value)
6.3.1	Nominal center frequency (fc)	314.35 MHz	
6.3.2	Insertion loss 1) 313.85 ~ 314.85 MHz (Pass bandwidth) 2) 10 ~ 270 MHz 3) 270 ~ 290 MHz 4) 290 ~ 295 MHz 5) 300 ~ 305 MHz 6) 308.85 ~ 309.30 MHz 7) 309.30 ~ 309.40 MHz 8) 309.40 ~ 309.85 MHz 9) 324 ~ 330 MHz 10) 335 ~ 340 MHz 11) 350 ~ 650 MHz 12) 650 ~ 1000 MHz	2.5 dB min 55 dB max 50 dB max 50 dB max 35 dB max 35 dB max 40 dB max 27 dB max 27 dB max 40 dB max 40 dB max 23 dB max	1.7 dB 70 dB 60 dB 58 dB 45 dB 47 dB 46 dB 42 dB 31 dB 56 dB 54 dB 44 dB
6.3.3	Ripple deviation (within 313.85-314.85MHz)	1.5 dB min	0.3 dB
6.3.4	VSWR (within 313.85-314.85MHz)	2.5 min	1.5

Test Measurement

(a) Measurement Circuit

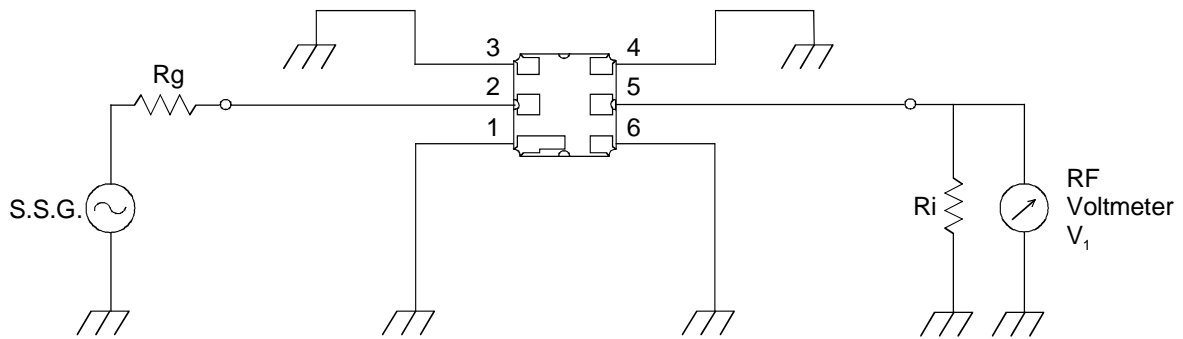

2 : input
5 : output
Other : ground

(b) 0dB level



R_g : 50Ω (Internal resistance of S.S.G.)

R_i : 50Ω (Input impedance of network analyzer or spectrum analyzer)

Resonant Loss or Insertion Loss = $20 \log (V_2 / V_1)$ [dB]

V_1 : Output Voltage of Test Circuit (a)

V_2 : Output Voltage of Test Circuit (b)

7. PHYSICAL AND ENVIRONMENTAL CHARACTERISTICS

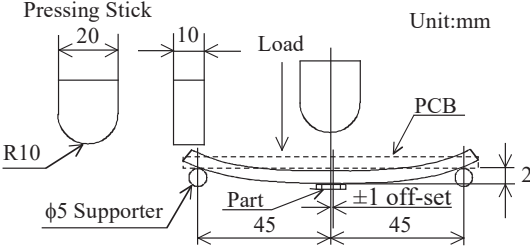
	Test Item	Test Condition	Criteria
7.1	PCB bend strength	<p>After soldering to a 1.6mm thick board and holding it as shown below, press the center of the board with a pressing jig five times at a rate of 1 second once, and deflect the board by 2mm. return.</p> 	No visible damage should be induced and the electrical performance should meet Table 1.
7.2	Flexural strength 2	Solder to a board with a thickness of 1.6 mm, hold it in the same manner as in 7.1, press the center of the board with a pressing jig five times at a rate of 1 second once, and deflect the board by 3 mm. return.	No abnormalities occur in the terminals and the body.
7.3	Vibration	<p>A sinusoidal vibration with a frequency of 10 to 500 Hz is applied in X, Y, and Z directions for 2 hours each as a 15 minute cycle.</p> <p>Amplitude conditions: 10 to 55 Hz: 0.75 mm amplitude 55 ~ 500Hz: acceleration amplitude 98m / s²</p>	The electrical performance should meet table 1
7.4	Shock resistance	Apply a load of 100g from a height of 150cm and drop it on a hard floor 5 times for 6 sides.	
7.5	Solderability	The terminals were immersed in a rosin ethanol solution (rosin ratio 20-25%) for about 5 seconds, and then H63A, H60A, or Sn-3.0Ag-0.5Cu of JIS-Z-3282 was melted at 230 ± 5 ° C. Immerse in solder bath for 5 ± 0.5 seconds.	Terminal surface area immersed Solder adheres to more than 3/4 of the part.
7.6	Resistance to solder heat	After preheating at 170 ± 10 ° C for 90 seconds or more, immerse in solder at 255 ± 5 ° C for 3 ± 1 seconds so that all electrodes are completely hidden. Remove from the bath to room temperature and measure 2 hours later.	The electrical performance should meet table 1
7.7	Temperature Characteristics	Measure in the range of -40 to + 110 ° C.	The electrical performance should meet chapter 6.1.
		Measure in the range of -40 to + 85 ° C.	The electrical performance should meet chapter 6.2
		Measure at 25 ± 2 ° C.	The electrical performance should meet chapter 6.3
7.8	Humidity	Keep in a thermo-hygrostat at a temperature of 60 ° C and a relative humidity of 90 to 95% for 1000 hours, take out at room temperature and measure after 2 hours.	The electrical performance should meet Table 1.
7.9	Life Test High Temperature	Hold in a thermostat at a temperature of 110 ° C for 1000 hours, take out at room temperature and measure 2 hours later.	
7.10	Life Test Low Temperature	Keep in a thermostat at -40 ° C for 1000 hours, take out at room temperature and measure 2 hours later.	
7.11	Thermal Shock	One cycle consists of -40 ° C for 30 minutes and + 110 ° C for 30 minutes. After 1000 cycles, take out at room temperature and measure 2 hours later.	
7.12	Reflow resistance	After performing reflow according to the reflow profile on page 9, take out at normal temperature and normal pressure and measure 24 hours later.	

7.13	Surge resistance	<p>Investigate and measure the voltage at the cumulative failure probability $F(t) = 10\%$ point on the Weibull probability paper with surge withstand voltage.</p> <p>(Measuring method)</p> <p>In the circuit diagram below, step up the DC voltage from 39V at intervals of the E12 series, and measure the voltage that causes the product to fail.</p> <p>No. of samples: 30 pcs or more</p> <p>Voltage application times: 1 time/step, (C=200pF)</p>  <p>From this result, plot the relationship between the applied voltage and the cumulative failure probability $F(t)$ on Weibull probability paper and check the surge voltage life distribution.</p> <p>(Failure criteria)</p> <p>If the amount of change (deterioration) from the initial value of the resonance loss (at the peak point) is 0.3dB or more, it is determined to be a failure (it is also determined to be a failure within the specifications).</p>	Satisfies 150V or more.
7.14	Salt spray resistance	Spray salt water at a temperature of 35 ° C and a concentration of $5 \pm 1\%$ for 48 hours, wash and dry, and measure 2 hours later.	The performance should meet Table 1.

Table 1. Electrical performance

Refer to the measurement circuit in section 6.

Test Item	Test Condition	Criteria
Nominal center frequency (fc)	314.35 MHz	
Insertion Loss		
1) 313.85 ~ 314.85 MHz (Pass Bandwidth)	2.5 dB or less	1.7 dB
2) 10 ~ 270 MHz	55 dB or more	70 dB
3) 270 ~ 290 MHz	50 dB or more	60 dB
4) 290 ~ 295 MHz	50 dB or more	58 dB
5) 300 ~ 305 MHz	35 dB or more	45 dB
6) 308.85 ~ 309.35 MHz	32 dB or more	47 dB
7) 309.35 ~ 309.85 MHz	25 dB or more	42 dB
8) 324 ~ 330 MHz	27 dB or more	31 dB
9) 335 ~ 340 MHz	40 dB or more	56 dB
10) 350 ~ 650 MHz	40 dB or more	54 dB
11) 650 ~ 1000 MHz	23 dB or more	44 dB
Ripple deviation (within 313.85-314.85MHz)	1.5 dB or less	0.3 dB
VSWR (within 313.85-314.85MHz)	3.0 or less	1.5

※The test is performed at a temperature of 25 ± 2 °C and a relative humidity of $65 \pm 5\%$.

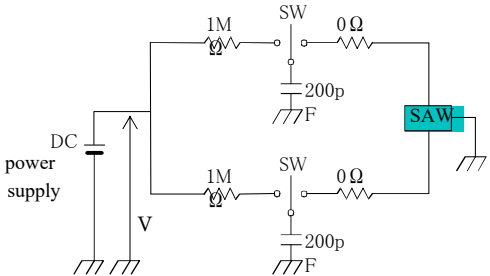
Reflow Profile

Profile A

- 1) Set the preheating temperature at 140-160 °C for 60-90 seconds.
- 2) The heating rate up to the preheating temperature of 150 °C shall be 30 seconds or more.
- 3) Set the heating temperature to 200 °C for 50-60 seconds and the peak temperature to 230 ± 10 °C.

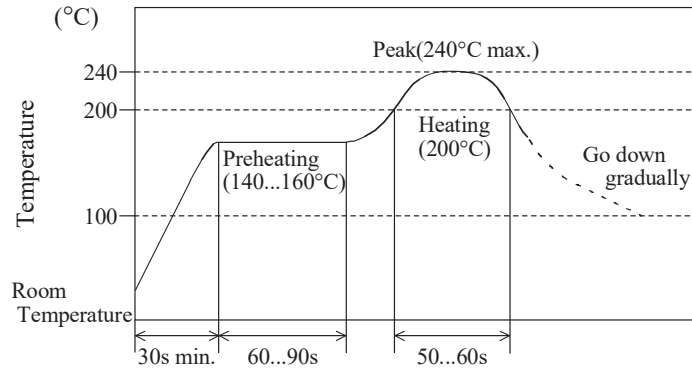

Profile B

- 1) Set the preheating temperature at 160~180 °C for 60-90 seconds
- 2) The heating speed up to the preheating temperature 170 °C shall be 40 seconds or more.
- 3) Heating temperature is 220 °C for 50-60 seconds, and peak temperature is 255 ± 5 °C.

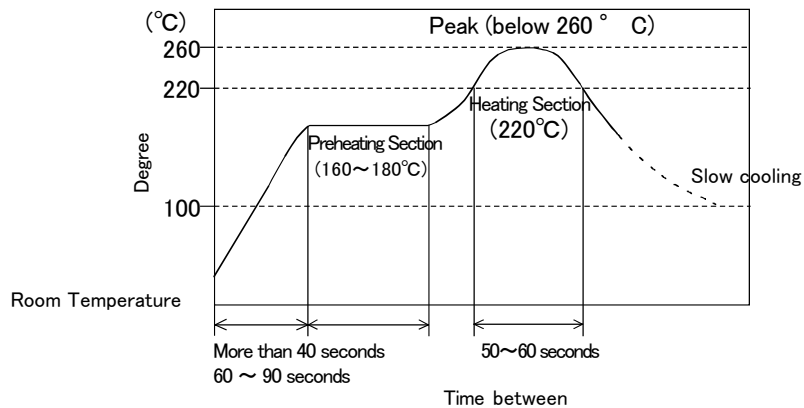

Recommended Land Pattern

- 1) Recommended land pattern is as follows.

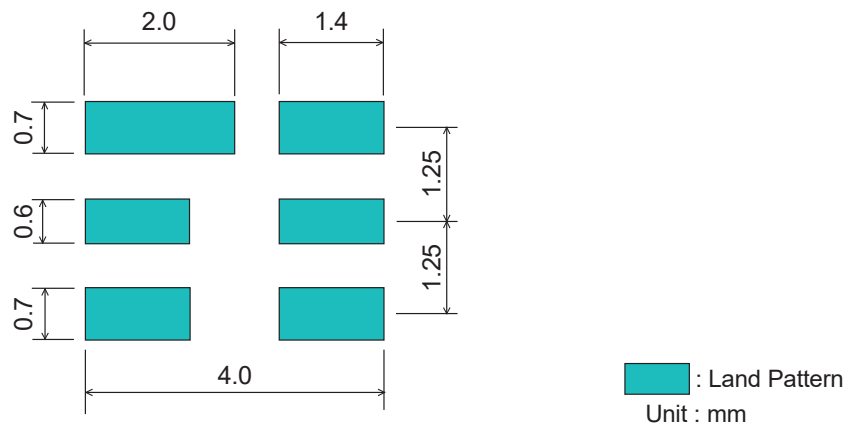

8. TAPING METHOD OF PLASTIC TAPE PACKAGE

8.1 Package

The package is packed so that it will not be damaged during transportation or storage, and the model name, quantity, and shipping inspection number will be displayed for each minimum packaging unit.

8.2 Dimensions of plastic tape

See figure 2

8.3 Taping Method

- 1) The tape shall be wound clockwise. (The feeding holes shall be to the right side when the tape is pulled toward user.)
- 2) Cover tape shall not cover the feeding holes of cavity tape or overlap the edge of cavity tape.
- 3) Trailer tape shall be 160...190 mm and leader cavity shall be 80...120 mm (refer to Figure. 1.)
- 4) The tip of the cover tape shall be adhered to the side of reel with adhesive tape (50...120 mm: Reference value).
- 5) The cover tape peel strength force shall be 0.2...0.6N (Reference value) which measured at 170 degrees with respect to the carrier tape.
- 6) The orientation is ruled as Figure. 2 shows.
- 7) All the filters shall be packed continuously into the tape without vacant cavities except the leader cavity and trailer tape area.
- 8) A reel shall contain 2000 pcs of filters.
(Please place the order with 2000 pcs times integer number. In case of small quantity shipment, bulk packing may be applied.)
- 9) Cover tape and cavity tape are made of anti-static material.
Part number, customer part number, quantity and inspection lot number shall be marked on each reel.
(The reel side containing the label will visible when the reel is oriented in a direction that dispenses the tape from the top of the reel and in a clockwise direction.)
- 1) The product which has ROHS-Y<*> mark on the packaging label is compliance with RoHS directives. The alphabet in blank <*> will be changed A to B, B to C, and so on with every revision of the RoHS directives. Please refer to the document, "The Marking for the directives on the restriction of the hazardous substances' use," to check the directives corresponding to alphabets in <*>.

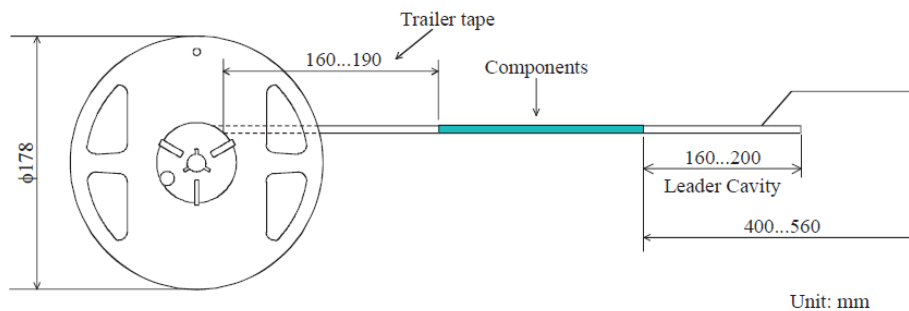

Figure. 1

Unit: mm

9. NOTICE

9.1 Usage Conditions

- 1) Use this component within operating temperature range. It might not meet the specification of electrical performance out of operating temperature range. Usage on the condition exceeding operating temperature range might cause degradation or destruction of the component. Even a short time usage on such conditions might cause degradation of reliability.

- 2) This product is designed for use of electrical equipment in the standard environment (temperature, humidity, atmospheric pressure etc.) Do not use in the following environments, since it causes degradation of characteristics and reliability.
 - Ambient air containing corrosive gas (Cl₂, H₂S, NH₃, SO_X, NO_X, etc.)
 - Ambient air containing combustible gas and substance with high volatility
 - In dusty place
 - In the places where the water splashes or precipitates
 - Under direct sunlight

 - In the places under the strong influence of static electricity or electric fieldContact us before using the component in such conditions.

- 3) This component can not be used in liquid (water, oil, chemical solution, organic solvents, etc.)

- 4) Apply electrical power lower than specified in the specification. When the component is used with higher rating power than specified in the specification, it might cause degradation or destruction of the component. Even if a short time, it might cause degradation of reliability under such a condition.

- 5) Do not let the component contact with other components, since its coating is not insulated.

- 6) Rapid temperature change of this component makes electric charge. Include discharge circuit between port and ground, since it might cause degradation or destruction of this component and other components around this component.

9.2 Storage Conditions

- 1) Keep the component in the package or sealed container on the following conditions.
[Temperature: -10...+40°C, Humidity: 30...85% R.H.]
Examine solderability before using this component, after longer than 6 months storage since it might cause degradation of solderability. Notice that long-term storage might cause discoloration.

- 2) To keep solderability of outer-electrode, do not store in the following environments.
 - Ambient air containing corrosive gas (Cl₂, H₂S, NH₃, SO_X, NO_X, etc.)
 - Ambient air containing combustible gas and substance with high volatility
 - In dusty place
 - In the places where the water splashes or precipitates
 - Under direct sunlight
 - In the places under the strong influence of static electricity or electric field

- 3) Do not open the package until usage.

9.3 Soldering Conditions

1) Solder under the following standard soldering conditions. If soldering under different conditions, please contact us in advance. Depending on the conditions, the function of the product may be impaired.

a. Soldering with solder iron

• Preheating Condition	—	150 °C ± 20 °C, over 60 seconds
• Temperature at tip of soldering iron	—	350°C±10°C
• Duration	—	within 5 seconds
• Diameter at tip of soldering iron	—	φ3mm max
• Power of soldering iron	—	30W max

When soldering the tip, do not touch the tip except the back and side terminals.

b. Reflow soldering

- Solder on the reflow soldering condition specified in this specification

- 2) Use land pattern recommended in this specification, since excess solder might cause destruction of chip by mechanical stress to supply too much solder.
- 3) Use rosin flux. Do not use strong acid flux [ex. Flux with more than 0.2wt% Halogen compound content (converted to chlorine content.)]
- 4) Use JIS-Z-3282 H63A, H60A, H50A solder or Lead free solder (Sn-3.0Ag-0.5Cu). Contact us before using other solders than above.
- 5) Solder with reflow soldering. Soldering with soldering iron shall be soldered on the condition specified in this specification. Since the lack of preheating gives this component rapid temperature change, it might cause degradation and destruction. Contact us before using the component on other conditions than specified in this specification.
- 6) Notice that the duration of soldering with soldering iron must be considered to be accumulated time, when soldering is repeated.
- 7) Use this component after examining that the outer electrodes are smoothly covered with solder thicker than 0.1mm.
 - 1) Isopropyl alcohol and ethyl alcohol can be used for cleaning. Contact us before using other cleaning solvents than above. Do not use flon, trichloroethane etc in the point of view to protect for global environment.
 - 2) Clean this component after ensuring that the temperature of the component is room temperature, since rapid temperature change by cleaning after reflow soldering might cause degradation or destruction.
 - 3) Do not use ultrasonic cleaning, since ultrasonic vibration might cause degradation or destruction.
 - 4) Dry this component immediately after cleaning.
 - 5) In the case that cleaning process is included in the manufacturing process, examine the influence to the performance of the component with mounting on PCB before use.

9.5 Handling Conditions

- 1) Notice that it might cause destruction to apply larger shock than specified in the specification while handling.
- 2) Notice that it might cause reliability degradation to apply excessive shock or vibration during transportation.
- 3) Do not apply any shock or pressure to this component during transportation when the component is on PCB.
- 4) Do not apply static electricity or excessive voltage while assembling and measuring, since it might cause degradation or destruction to apply static electricity to this component.
- 5) Do not handle this component with bare hand.

9.6 Mounting Conditions

- 1) Mount this component not to apply a stress caused by warp or bend of PCB.
- 2) Abraded positioning claw, pick-up nozzle, etc of component placement machine might apply excessive shock on the component on PCB and cause destruction. Keep the maintenance which is instructed on each machine regularly to prevent the component from these kinds of troubles.
- 3) Mount all terminals, or terminal strength might be degraded.
- 4) Mount the component on PCB with no space between component and PCB.

9.7 Limitation of Applications

Please contact us before using our products for the applications listed below which require especially for the prevention of defects which might directly cause damage to the third party's life, body or property.

- a. Aircraft equipment
- b. Aerospace equipment
- c. Undersea equipment
- d. Nuclear control equipment
- e. Medical equipment
- f. Transportation equipment (vehicles, trains, ships, etc.)
- g. Traffic signal equipment
- h. Disaster prevention / crime prevention equipment
- i. Data - processing equipment
- j. Application of similar complexity and / or reliability requirements to the applications listed in the above

NOTE

- 1) Please make sure that your product has been evaluated in view of your specifications with our product being mounted to your product.
- 2) You are requested not to use our product deviating from the agreed specifications.
- 3) We consider it not appropriate to include any terms and conditions with regard to the business transaction in the product specifications, drawings or other technical documents. Therefore, if your technical documents as above include such terms and conditions such as warranty clause, product liability clause, or intellectual property infringement liability clause, they will be deemed to be invalid.