

SF1186G-6

1575.5 MHz SAW Filter

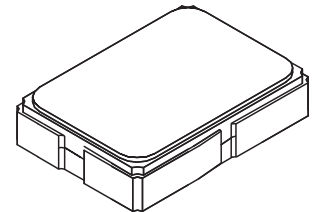

SM2520-6

- RF filter designed for front end GPS applications
- Low Insertion Loss
- 2.0 x 2.5 x 0.75 mm Surface Mount Case
- Complies with Directive 2002/95/EC (RoHS)
- Moisture Sensitivity Level: 1
- AEC-Q200 Qualified

Absolute Maximum Ratings

Rating	Value	Units
Input Power Level	+17	dBm
DC Voltage	3	V
Operating Temperature Range	-40 to +85	°C
Storage Temperature Range in Tape and Reel	-40 to +85	°C

Electrical Characteristics

Characteristic	Sym	Notes	Min	Typ	Max	Units
Center Frequency	F_C			1575.42		MHz
Insertion Loss, 1574 to 1577 MHz	IL			1.5	1.9	dB
Amplitude Ripple, 1574 to 1577 MHz				0.2	0.5	
VSWR, 1574 to 1577 MHz				1.5	1.8	
Amplitude Balance 1574 to 1577 MHz			-1.6	± 1.3	+1.6	dB
Phase Balance 1574 to 1577 MHz			170	180 ± 4	190	deg
Attenuation Referenced to 0 dB:						dB
100 to 1475 MHz			30	47		
1475 to 1525 MHz			15	33		
1625 to 1675 MHz			9	22		
1675 to 3000 MHz			30	33		
3000 to 6000 MHz			25	30		
Case Style	SM2520-6 Nominal Footprint					
Lid Symbolization (Y=year, WW=week, S=shift) dot = pin 1 indicator	5A, YWWWS					
Standard Reel Quantity	Reel Size 7 Inch					2,000 Pieces/Reel
	Reel Size 13 Inch					10,000 Pieces/Reel

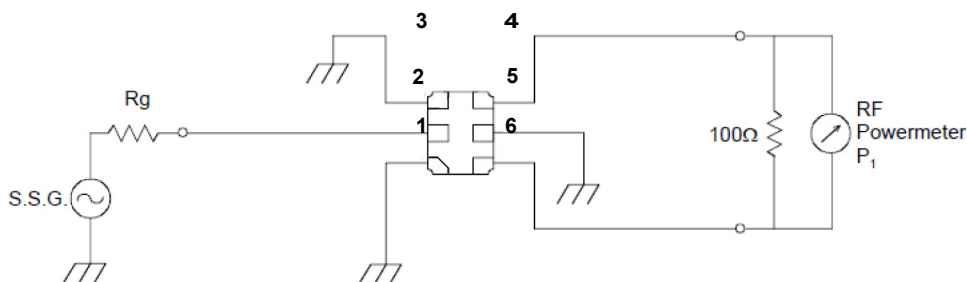

Connection	Terminals
Input	2
Output	4, 6
Ground	All Others

 **CAUTION: Electrostatic Sensitive Device. Observe precautions for handling.**
NOTES:

1. The design, manufacturing process, and specifications of this device are subject to change.
2. US or International patents may apply.
3. RoHS compliant from the first date of manufacture.

Frequency Characteristics

S21 Response (span 500 MHz)

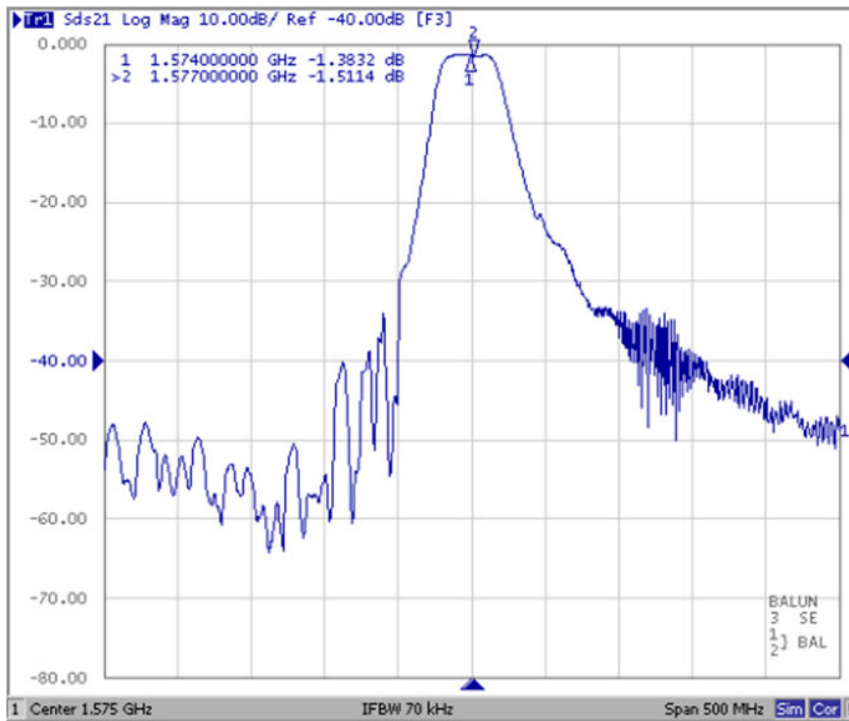

S21 Response (span 6 GHz)

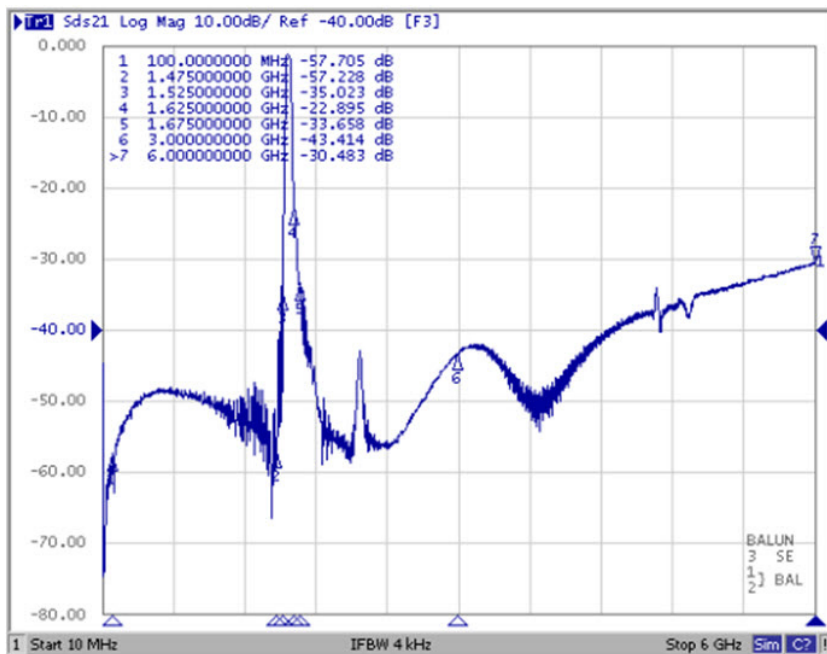

Frequency Characteristics (continued)

S21 Response (span 100 MHz)

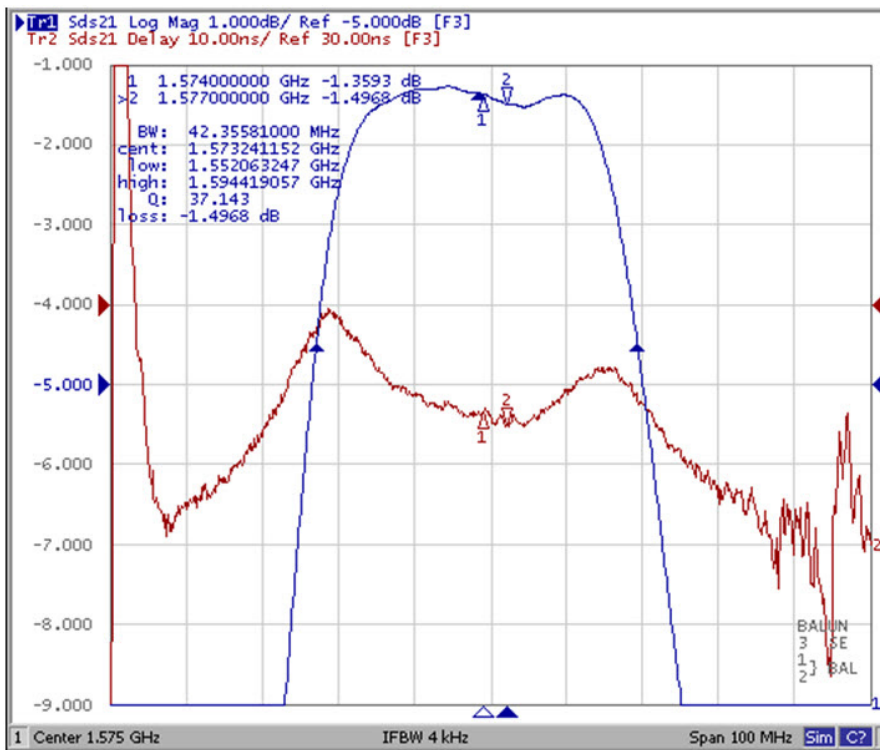

S11 and S22 VSWR (span 6 GHz)

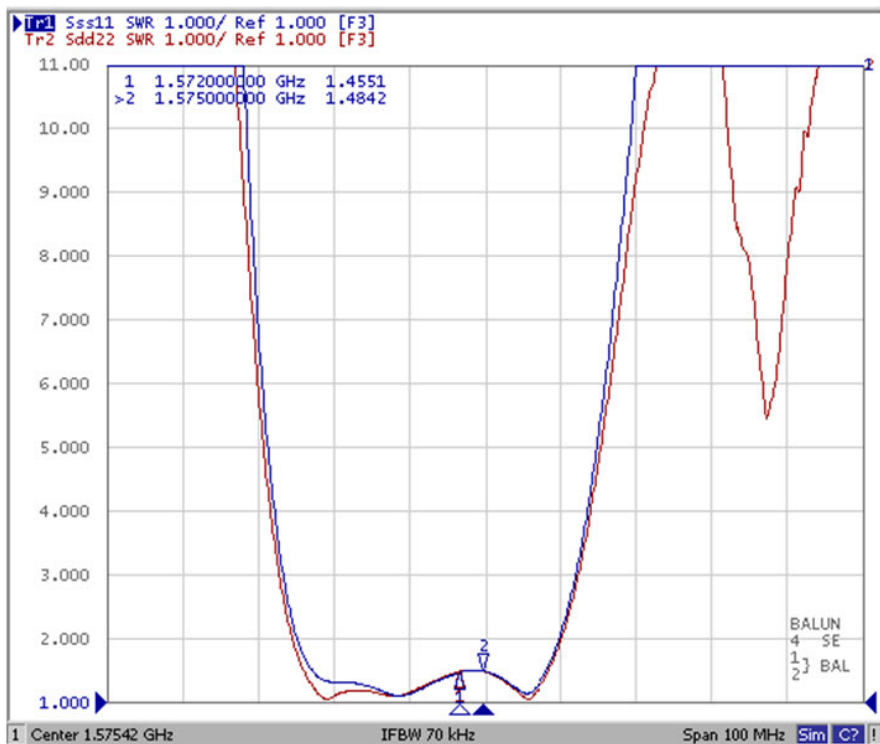

Physical and Environmental Characteristics

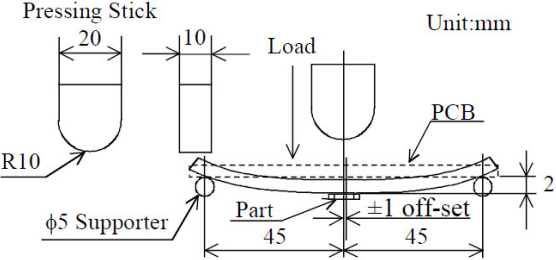
Test Item	Test Condition	Criteria
PCB Bend Strength	<p>Filter is soldered onto the center of 0.8mm thickness PCB which is laid on the two small supporters spaced 90mm as shown in below figure. PCB is deflected to 2mm below from horizontal level by the pressing stick. The force is supplied for 1 second - 5 times repeatedly.</p> 	<p>No visible damage should be induced.</p>
Vibration	<p>The electrical performance is measured after being applied vibration of amplitude of 1.5mm with 10 to 55Hz of vibration frequency to each of 3 perpendicular directions for 2 hours.</p>	
Drop Test	<p>The electrical performance is measured after dropping with housing (around 100g) from a height of 150cm onto the concrete plate 3 times in each of 6 perpendicular directions.</p>	
Solderability	<p>Terminals are immersed in rosin flux (concentration 20...25%, solvent: ethanol 75...80%) for 5 seconds, then immersed in soldering bath at $230\pm 5^{\circ}\text{C}$ (solder: JIS-Z-3282 H63A, H60A or Sn-3.0Ag-0.5Cu) for 5 ± 0.5 seconds.</p>	<p>90% minimum of the immersed surface should be covered with solder.</p>
Resistance to Soldering Heat	<p>Filter is preheated at $170\pm 10^{\circ}\text{C}$ for 90 seconds, immersed whole electrode in soldering bath at $255\pm 5^{\circ}\text{C}$ for 3 ± 1 seconds, then measured after being placed in standard atmospheric conditions for 2 hours.</p>	
Humidity	<p>The electrical performance is measured after being placed in a chamber with 90...95% R.H. at 60°C for 500 hours and then being placed in standard atmospheric conditions for 2 hours.</p>	
Life Test (High Temperature)	<p>The electrical performance is measured after being placed in a chamber with 85°C for 500 hours and then being placed in standard atmospheric conditions for 2 hours.</p>	
Life Test (Low Temperature)	<p>The electrical performance is measured after being placed in a chamber with -40°C for 500 hours and then being placed in standard atmospheric conditions for 2 hours.</p>	
Thermal Shock	<p>After temperature cycling of -55°C for 30 minutes to $+85^{\circ}\text{C}$ for 30 minutes performed 100 times, filter shall be returned to room temperature. And the electrical performance is measured after being placed in standard atmospheric conditions for 2 hours.</p>	
Resistance to Reflow Soldering	<p>The electrical performance is measured after being soldered by reflow 2 times with the following reflow profile A or B and then being placed in standard atmospheric conditions for 24 hours.</p>	

Reflow Profile

Profile A

1. Preheating shall be fixed at 140...160°C for 60...90 seconds.
2. Ascending time to preheating temperature 150°C shall be 30 seconds minimum.
3. Heating shall be fixed at 200°C for 50...60 seconds and at 230±10°C peak.

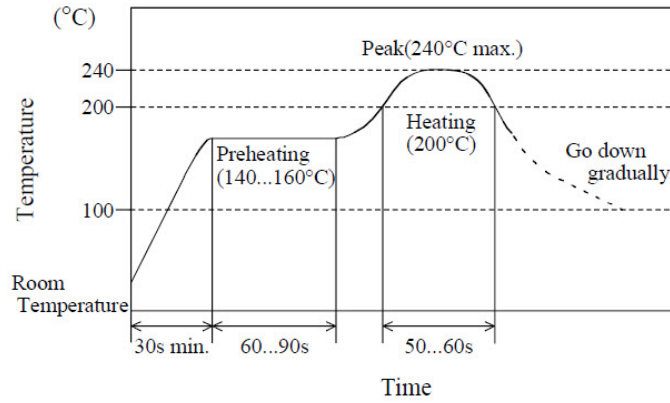

Profile B

1. Preheating shall be fixed at 160...180°C for 60...90 seconds.
2. Ascending time to preheating temperature 170°C shall be 40 seconds minimum.
3. Heating shall be fixed at 220°C for 50...60 seconds and at 255±5°C peak.

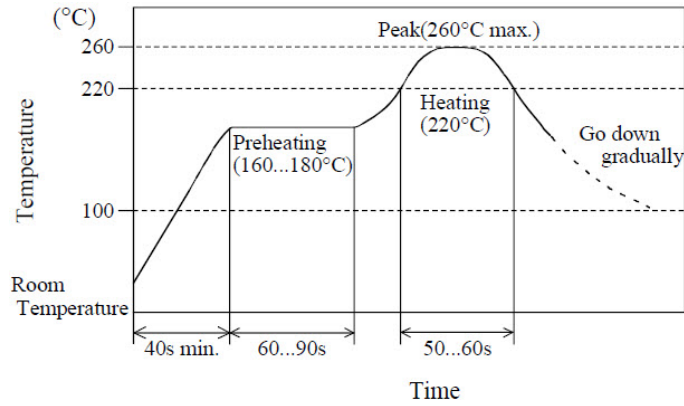

Recommended Land Pattern

1. Recommended land pattern is as follows.

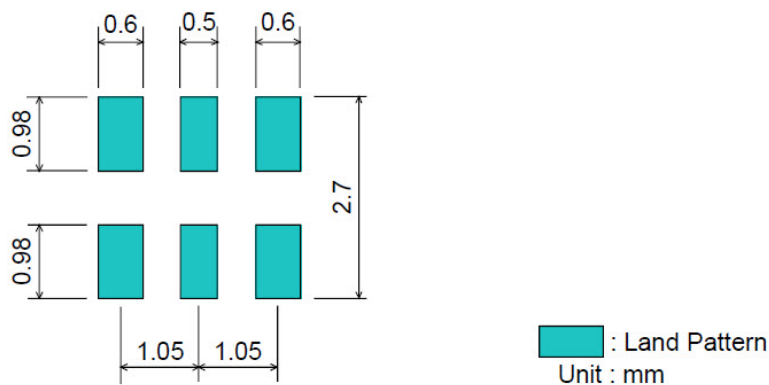

SM2520-6 Case

6-Terminal Ceramic Surface-Mount Case 2.5 X 2.0 mm Nominal Footprint

Case and PCB Footprint Dimensions

Dimension	mm			Inches		
	Min	Nom	Max	Min	Nom	Max
A	-	2.00	-	-	0.078	-
B	-	2.50	-	-	0.098	-
C	-	0.50	-	-	0.029	-
D	-	0.75	-	-	0.019	-
E	-	1.00	-	-	0.039	-
F	-	0.50	-	-	0.019	-
G	-	0.50	-	-	0.019	-
H	-	0.74	-	-	0.029	-
I	-	0.50	-	-	0.019	-
J	-	0.63	-	-	0.024	-

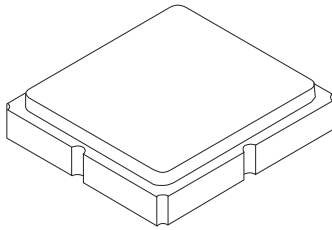

TOP VIEW

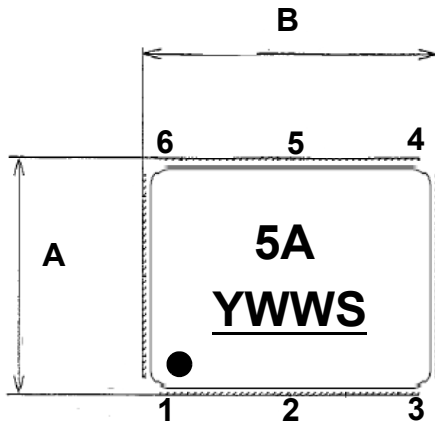

BOTTOM VIEW

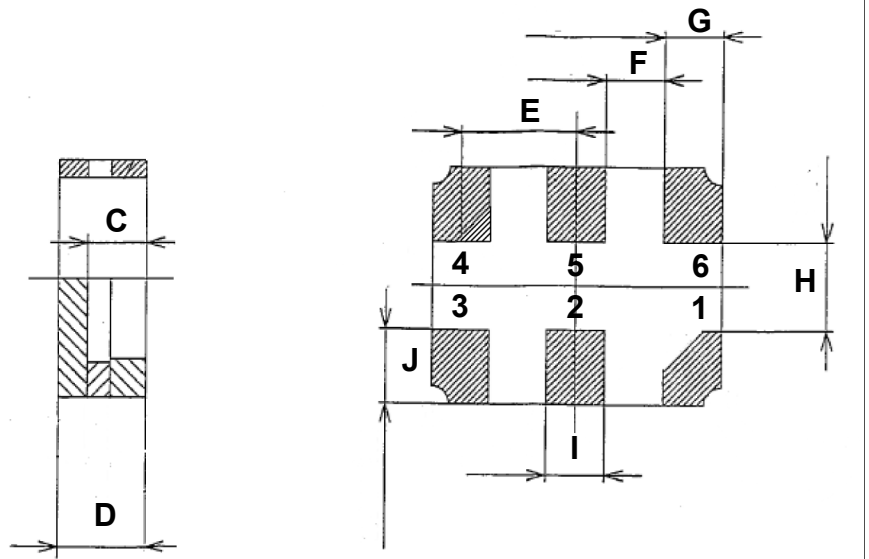

Tape and Reel Specifications

Tape and Reel Standard per ANSI/EIA-481

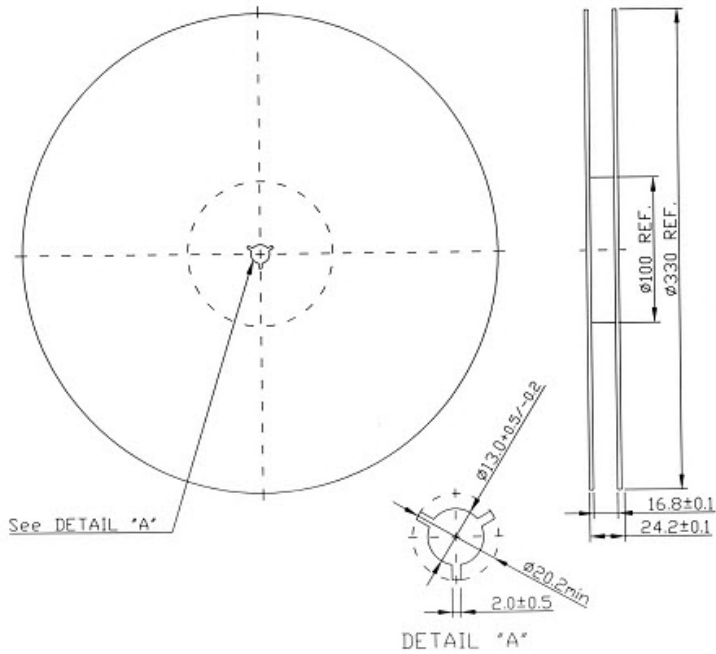

"B"		Quantity Per Reel
Inches	millimeters	
7	178	2000
13	330	10000

COMPONENT ORIENTATION and DIMENSIONS

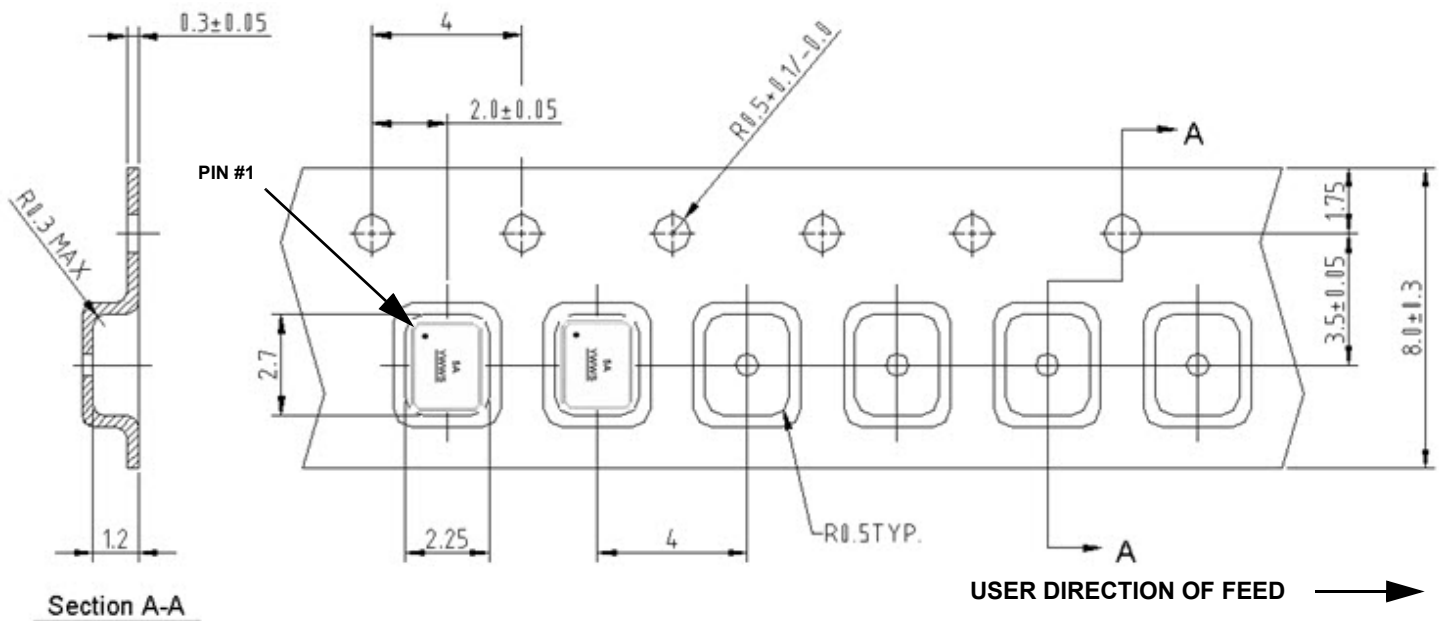

Recommended Reflow Profile

1. Preheating shall be fixed at 150~180°C for 60~90 seconds.
2. Ascending time to preheating temperature 150°C shall be 30 seconds min.
3. Heating shall be fixed at 220°C for 50~80 seconds and at 260°C+0/-5°C peak (10 seconds).
4. Time: 5 times maximum.

