

SF2537N

**836.5/881 MHz
Filter Duplexer**

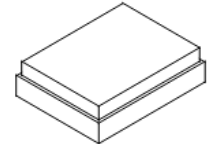

SM1814

MAXIMUM RATING:

- Operating temperature range: -20 °C to +85 °C
- Storage temperature range: -40 °C to +85 °C
- Tx Input power : 29dBm (Ta=+50°C,50000h,CW)
- Maximum DC Voltage: 3 V
- Moisture Sensitivity Level: Level 3 (MSL 3)
- ESD 100V(MM) 200V(HBM)

ELECTRICAL CHARACTERISTICS:

Terminating impedance (Tx Port): 50 Ω (Single-ended)

Terminating impedance (Rx Port): 50 Ω (Single-ended)

Terminating impedance (Ant Port): 50 Ω (Single-ended)

Tx to ANT (f_{T0}=836.5 MHz)

Parameters Description		Unit	Min	Typ	Max	Remarks
Insertion Loss	824 ~ 849 MHz	dB	-	1.6	2.0	
Amplitude ripple	824 ~ 849 MHz	dB	-	0.6	1.5	
VSWR	ANT	824 ~ 849 MHz	-	-	1.7	2.0
	Tx	824 ~ 849 MHz	-	-	1.7	2.0
Attenuation:						
10 ~ 420 MHz		dB	35	39	-	
420 ~ 494 MHz		dB	35	38	-	
494 ~ 701 MHz		dB	33	37	-	
699 ~ 716 MHz		dB	35	42	-	
701 ~ 728 MHz		dB	35	42		
704 ~ 716 MHz		dB	35	42	-	
728 ~ 764 MHz		dB	35	40	-	
764 ~ 804 MHz		dB	30	35	-	
860 ~ 869 MHz		dB	5	12	-	
869 ~ 894 MHz		dB	45	47		
1559 ~ 1563 MHz		dB	25	29		
1565.42 ~ 1573.37 MHz		dB	25	29		
1573.37 ~ 1577.47 MHz		dB	25	29		
1577.47 ~ 1585.42 MHz		dB	25	29		
1597.55 ~ 1605.89 MHz		dB	25	29		

1683 ~ 1708 MHz	dB	25	28		
1710 ~ 1785 MHz	dB	25	27		
1844.9 ~ 1879.9 MHz	dB	23	26		
1884.5 ~ 1919.6 MHz	dB	23	26		
1920 ~ 1980 MHz	dB	22	26		
2110 ~ 2170 MHz	dB	20	25		
2400 ~ 2494 MHz	dB	20	23		
3286 ~ 3406 MHz	dB	15	19		
4110 ~ 4255 MHz	dB	12	22		
4900 ~ 5950 MHz	dB	10	25		
6582 ~ 6802 MHz	dB	15	32		
7406 ~ 7651 MHz	dB	15	38		



CAUTION: Electrostatic Sensitive Device. Observe precautions for handling.

NOTES:

1. The design, manufacturing process, and specifications of this device are subject to change.
2. US or International patents may apply.
3. RoHS compliant from the first date of manufacture.

ANT to Rx (f_{T0}=881.5 MHz)

Parameters Description		Unit	Min	Typ	Max	Remarks
Insertion Loss	871.5 ~ 891.5 MHz	dB	-	1.9	2.1	
Amplitude ripple	869 ~ 894 MHz	dB	-	0.6	1.5	
VSWR	Rx	-		1.8	2.2	
	ANT	-		1.8	2.2	
Attenuation:						
10 ~ 477 MHz		dB	35	45	-	
45 MHz		dB	50	80	-	
447 ~ 824 MHz		dB	32	43		
779 ~ 804 MHz		dB	35	45		
824 ~ 849 MHz		dB	50	55	-	
1693 ~ 1743 MHz		dB	40	55	-	
1710 ~ 1785 MHz		dB	40	55		
1788 ~ 1788 MHz		dB	40	57		
1850 ~ 1920 MHz		dB	40	58		
1920 ~ 1980 MHz		dB	40	57		
1980 ~ 2400 MHz		dB	40	53		
2305 ~ 2315 MHz		dB	40	53		
2400 ~ 2500 MHz		dB	40	52		
2467 ~ 2494 MHz		dB	40	52		
2517 ~ 2592 MHz		dB	35	43		
2607 ~ 2682 MHz		dB	35	51		
3476 ~ 3576 MHz		dB	30	50		
4345 ~ 4470 MHz		dB	25	41		
4900 ~ 5950 MHz		dB	20	38		
5214 ~ 5364 MHz		dB	25	36		
6083 ~ 6258 MHz		dB	20	40		
6952 ~ 7152 MHz		dB	15	41		

Tx to Rx

Isolation	824 ~ 849 MHz	dB	53	57	-	
	869 ~ 894 MHz	dB	50	53	-	
	1574 ~ 1577 MHz	dB	40	58		
	1683 ~ 1708 MHz	dB	20	58		
	2462 ~ 2557 MHz	dB	20	66		

Notes : (1) With Matching Network

FREQUENCY CHARACTERISTICS:

Tx to Ant

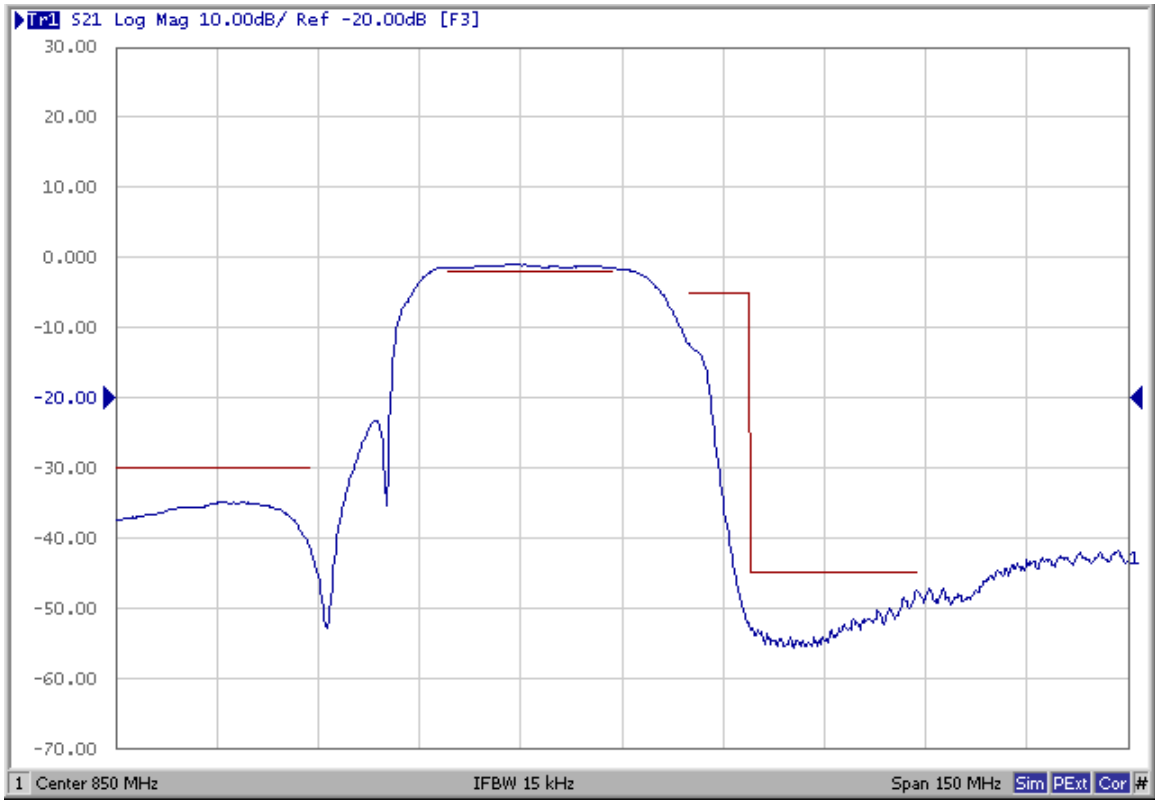

Ant to Rx



Isolation

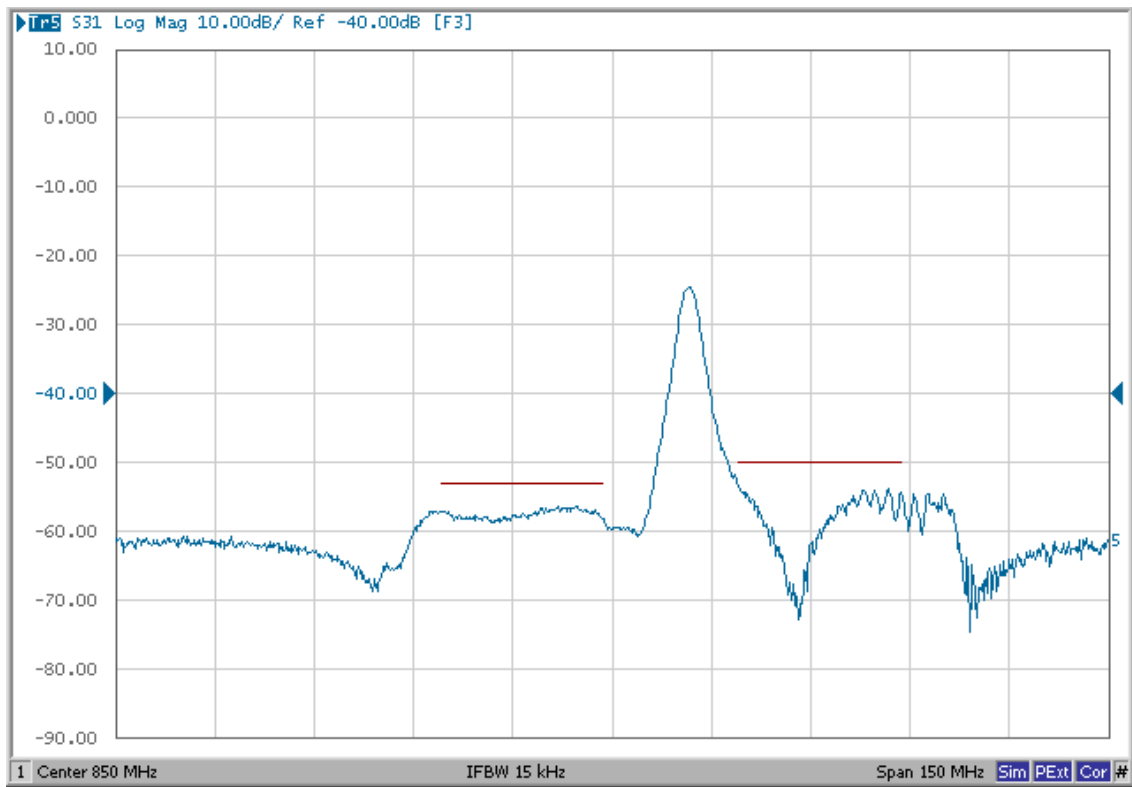

VSWR (Tx Port)

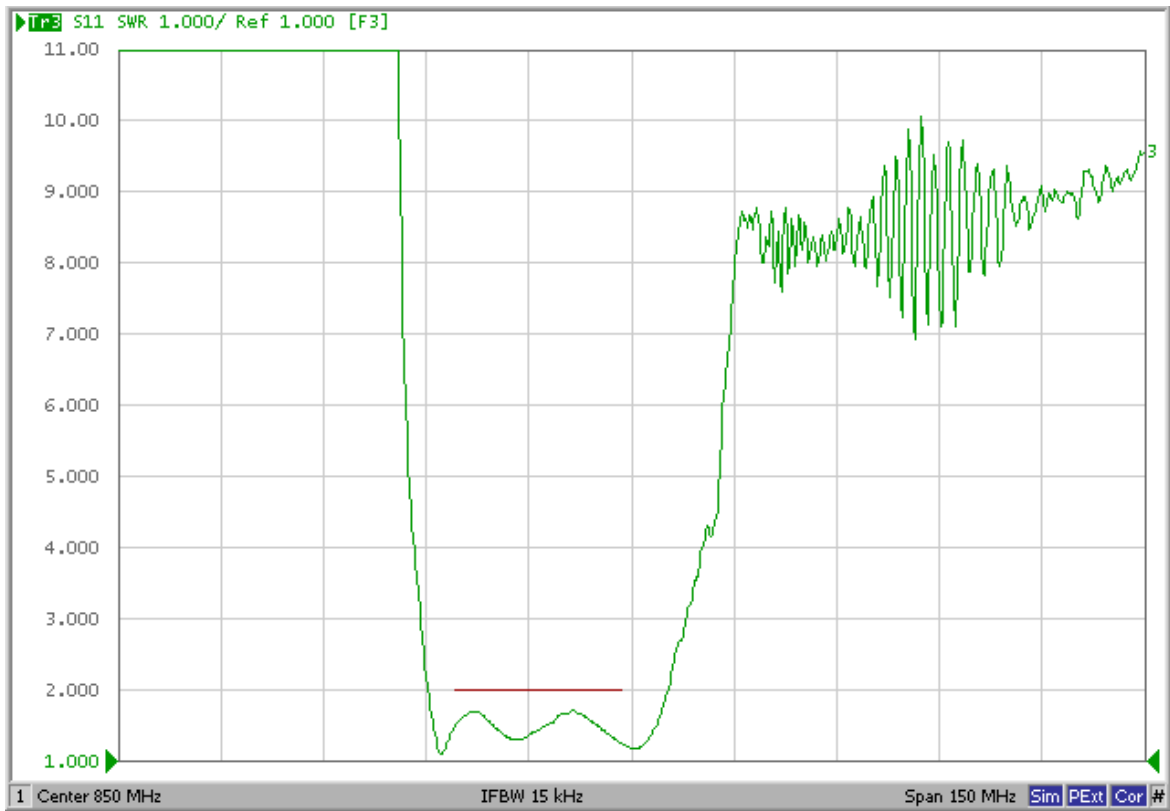

VSWR (Rx Port)

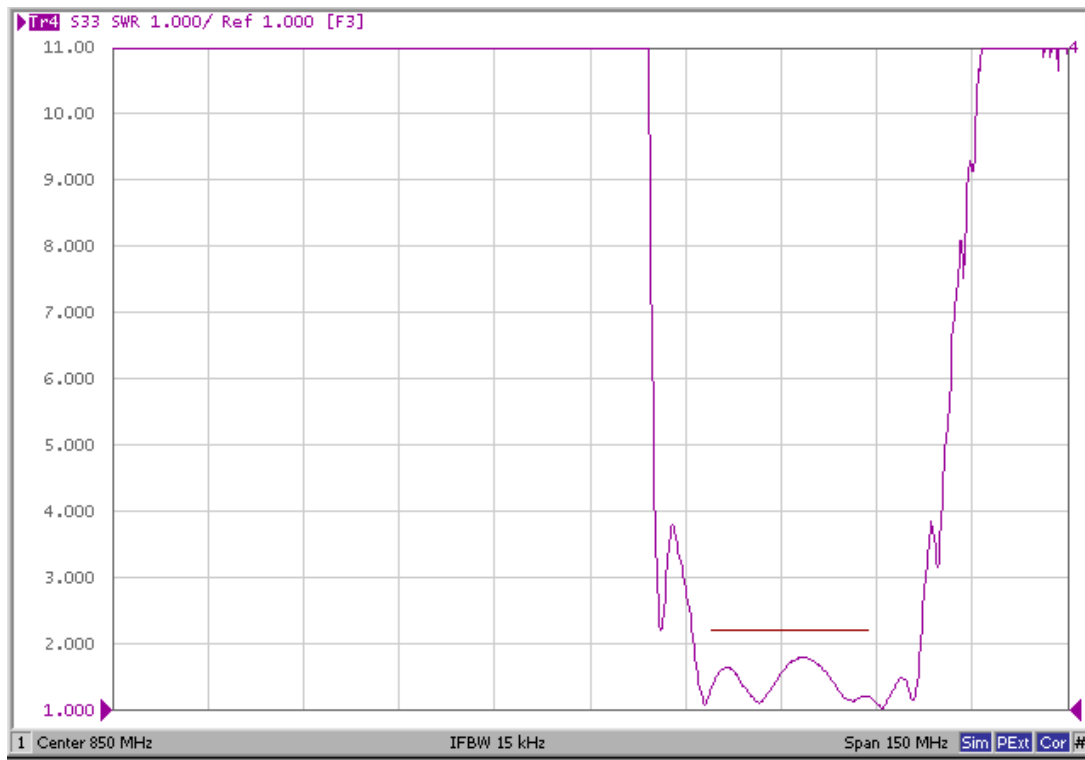

VSWR (ANT Port)

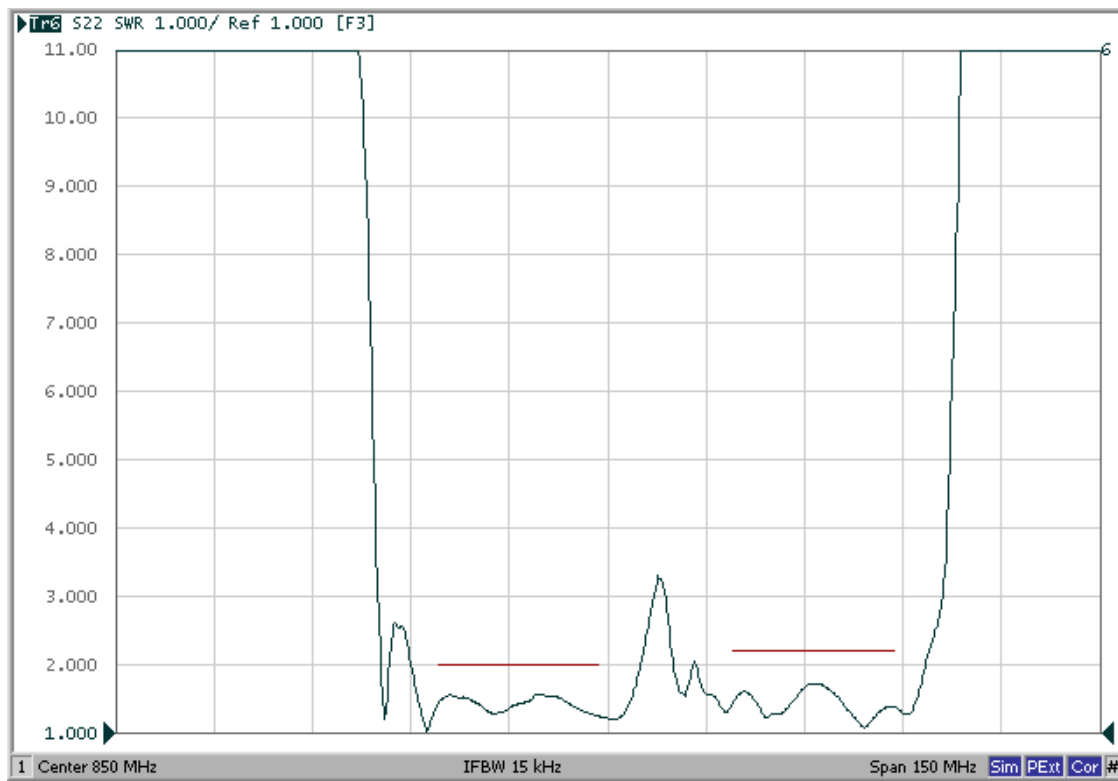

Wide Span

Wide Span

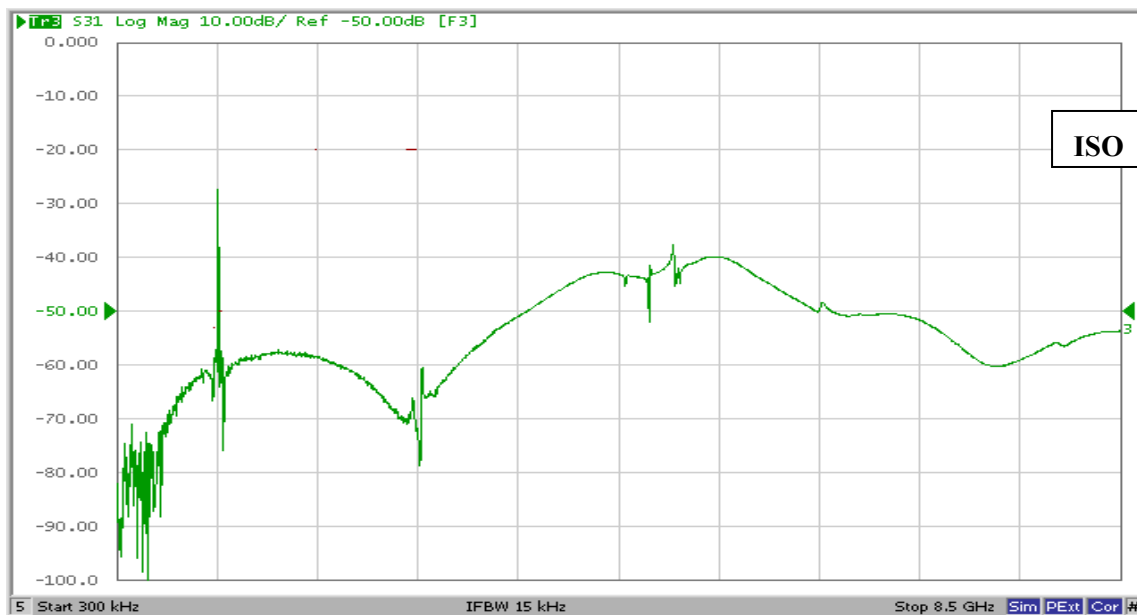

OUTLINE DRAWING:

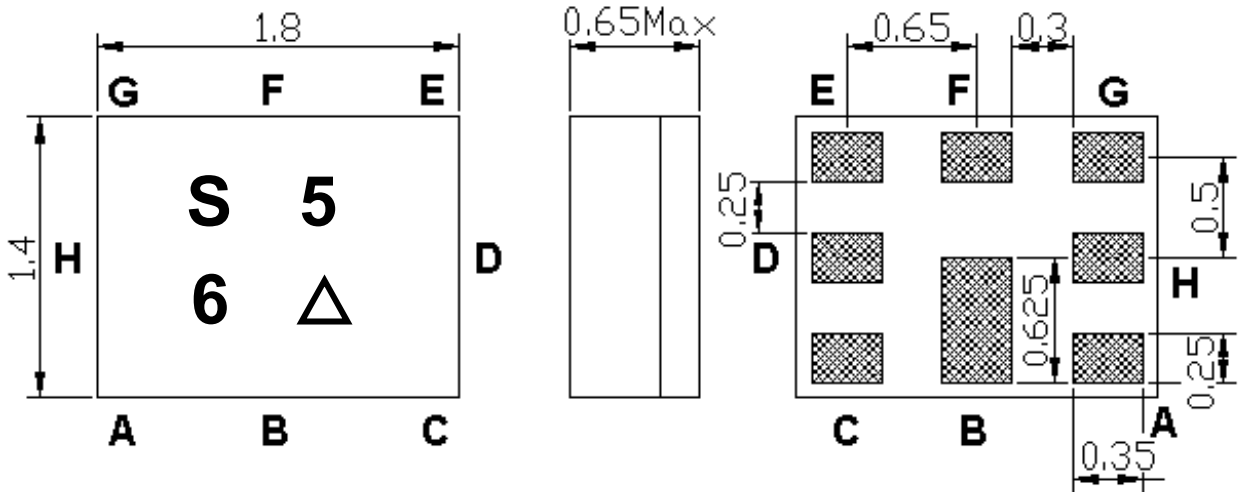

Marking Descriptions	
S	Marking name
5	Band Class
6	Series Number
△	Date Code(Year+Month)

Pin Description	
B,D,E,G,H	Ground
F	Ant
C	Tx (836.5MHz)
A	Rx (881.5MHz)

Date Code (year+month)

Year	Jan.	Feb.	Mar.	Apr.	May.	Jun.	Jul.	Aug.	Sep.	Oct.	Nov.	Dec.
2013	A	B	C	D	E	F	G	H	J	K	L	M
2014	N	P	Q	R	S	T	U	V	W	X	Y	Z
2015	a	b	c	d	e	f	g	h	j	k	l	m
2016	n	p	q	r	s	t	u	v	w	x	y	z
2017	<u>A</u>	<u>B</u>	<u>C</u>	<u>D</u>	<u>E</u>	<u>F</u>	<u>G</u>	<u>H</u>	<u>J</u>	<u>K</u>	<u>L</u>	<u>M</u>
2018	<u>N</u>	<u>P</u>	<u>Q</u>	<u>R</u>	<u>S</u>	<u>T</u>	<u>U</u>	<u>V</u>	<u>W</u>	<u>X</u>	<u>Y</u>	<u>Z</u>
2019	<u>a</u>	<u>b</u>	<u>c</u>	<u>d</u>	<u>e</u>	<u>f</u>	<u>g</u>	<u>h</u>	<u>j</u>	<u>k</u>	<u>l</u>	<u>m</u>
2020	<u>n</u>	<u>p</u>	<u>q</u>	<u>r</u>	<u>s</u>	<u>t</u>	<u>u</u>	<u>v</u>	<u>w</u>	<u>x</u>	<u>y</u>	<u>z</u>

Evaluation Circuit

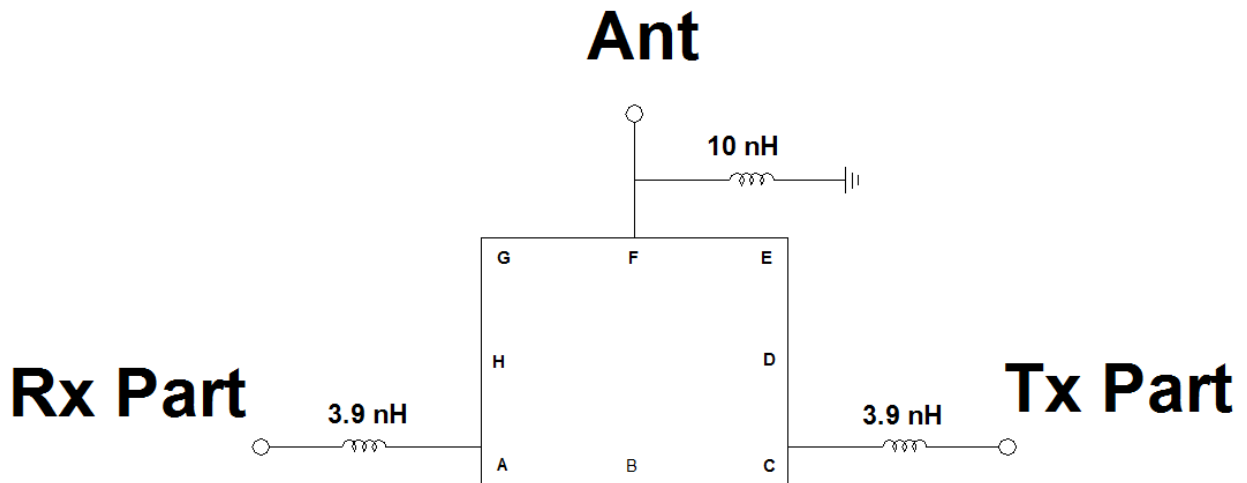

FOOTPRINT:

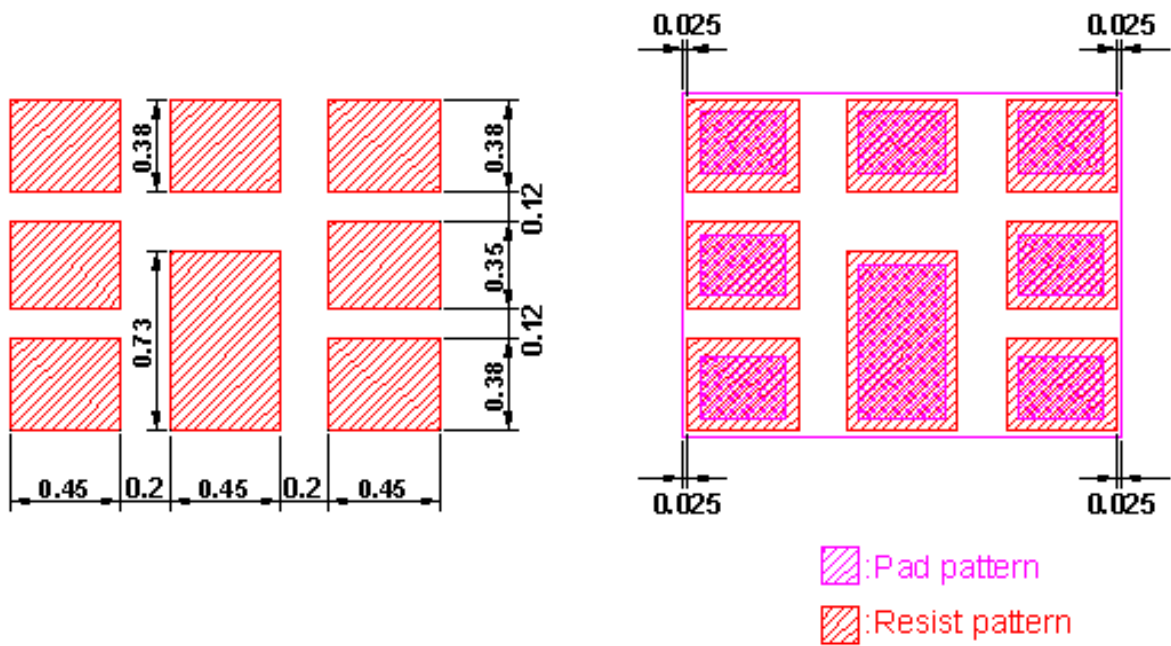

PACKING:

Reel Count:
 7" = 3000
 13" = 10,000

REEL DIMENSION

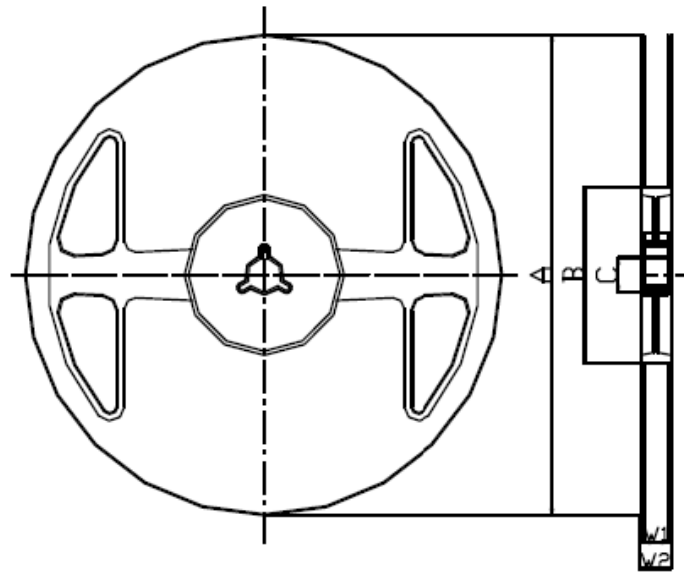

Materials of Reel

Material : Polystyrene + Carbon
 Characteristics : Conforms to EIAJ-ET-7200A
 Color : Black
 Surface resistance (reference value) : $10^9\Omega/\text{sq}$ Max.

Unit : mm

Code	Quantity	A	B	C	W1	W2
Z	3,000 pcs	$\phi 180.0 +0.0/-1.5$	$\phi 66.0 +/-0.5$	$\phi 13.0 +/-0.2$	$9.0 +1.0/-0.0$	$11.4 +/-1.0$

TAPE DIMENSION

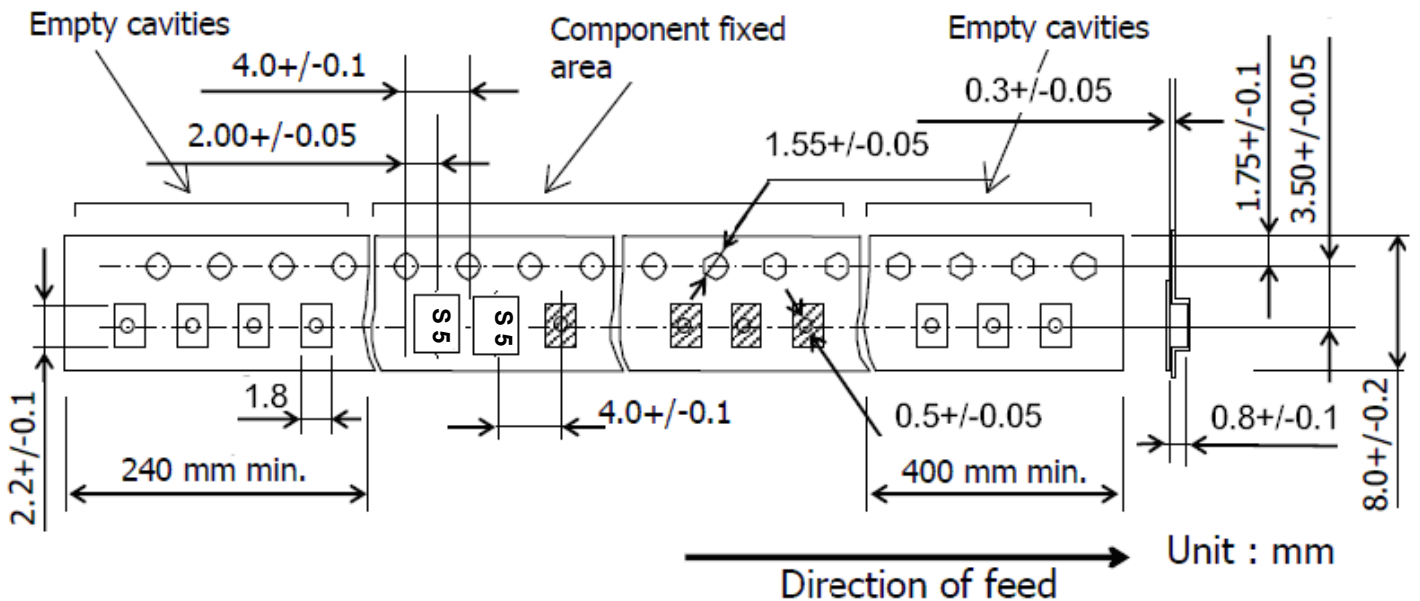

Unit : mm

RECOMMENDED REFLOW PROFILE :

1. Preheating shall be fixed at 150~180°C for 60~90 seconds.
2. Ascending time to preheating temperature 150°C shall be 30 seconds min.
3. Heating shall be fixed at 220°C for 50~80 seconds and at 245~260°C peak (min. 10sec).
4. Time : 2 times.

