

SF2569LM

**2355 MHz
SAW Filter**

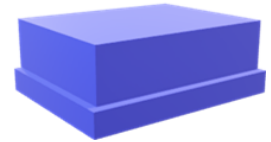

SM1109

MAXIMUM RATING

- Input Power Level: +20dBm (Ta=+50deg C,5000h,CW)
- DC Voltage : 5V
- Operating Temperature: -20°C to +85°C
- Storage Temperature: -40°C to +100°C
- Moisture Sensitivity Level: Level 3 (MSL 3)
- ESD 50V(MM) 100V(HBM)

ELECTRICAL CHARACTERISTICS

Terminating source impedance : $Z_s = 50 \ \Omega$ (Single-ended)

Terminating load impedance : $Z_L = 50 \ \Omega$ (Single-ended)

Item	Unit	Min.	Typ.	Max.	Note
Center Frequency Fc	MHz	-	2355	-	-
Insertion Loss (2350 ~2360MHz) IL	dB(*1)	-	2.1	2.9	
Ripple (2350 ~2360MHz) dB	dB		0.3	1.2	
Input VSWR (2350 ~2360MHz)		-	1.6	2.0	-
Output VSWR (2350 ~2360MHz)			1.5	2.0	
Attenuation (reference level from 0 dB)					
1~ 2305 MHz	dB	35	41	-	
2305 ~ 2315 MHz	dB	39	50		
2400 ~ 2500 MHz	dB	35	38		
2500 ~ 2570 MHz	dB	40	43		
2570 ~ 6000 MHz	dB	22	32		

(*1) Specification of insertion loss excludes loss that comes from the test board.

CAUTION: Electrostatic Sensitive Device. Observe precautions for handling.



1. The design, manufacturing process, and specifications of this device are subject to change.
2. US or International patents may apply.
3. RoHS compliant from the first date of manufacture.

OUTLINE DRAWING

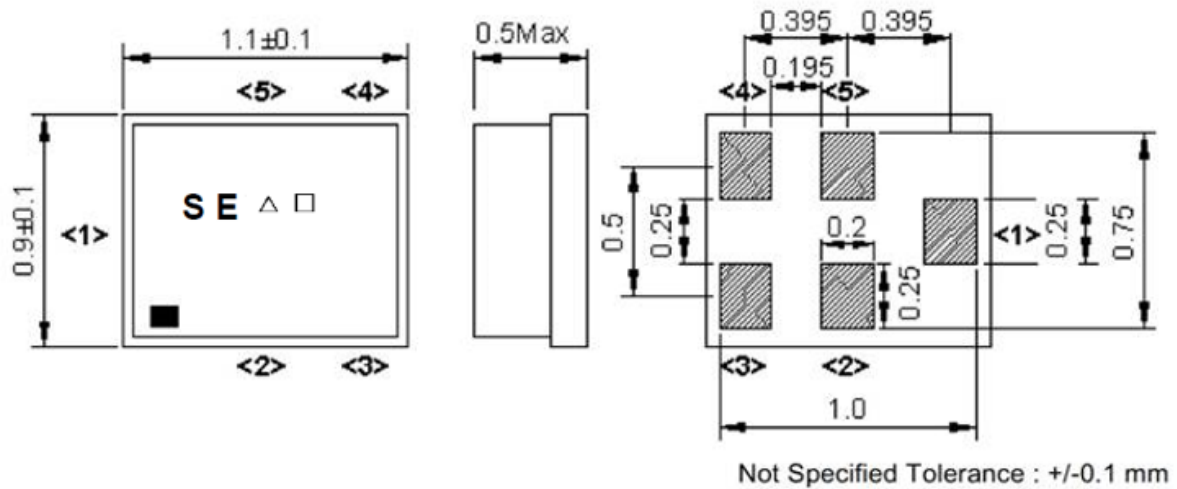

Pin assignment

Pin No.	Pin name	Description
1	In	Input
2	GND	Ground
3	GND	Ground
4	Out	Output
5	GND	Ground

Figure 1. Dimensions and Pin assignment

Marking:



Marking name : SE

△ : Date Code

□ : Lot No. (Indicated by 0~9 or A to Z and a to z, except I, O, i, o and l)

Date Code

Year	Jan	Feb	Mar	Apr	May	Jun	Jul	Aug	Sep	Oct	Nov	Dec
2017 / 2021	A	B	C	D	E	F	G	H	J	K	L	M
2018 / 2022	N	P	Q	R	S	T	U	V	W	X	Y	Z
2019 / 2023	a	b	c	d	e	f	g	h	j	k	l	m
2020 / 2024	n	p	q	r	s	t	u	v	w	x	y	z

MEASUREMENT CIRCUIT

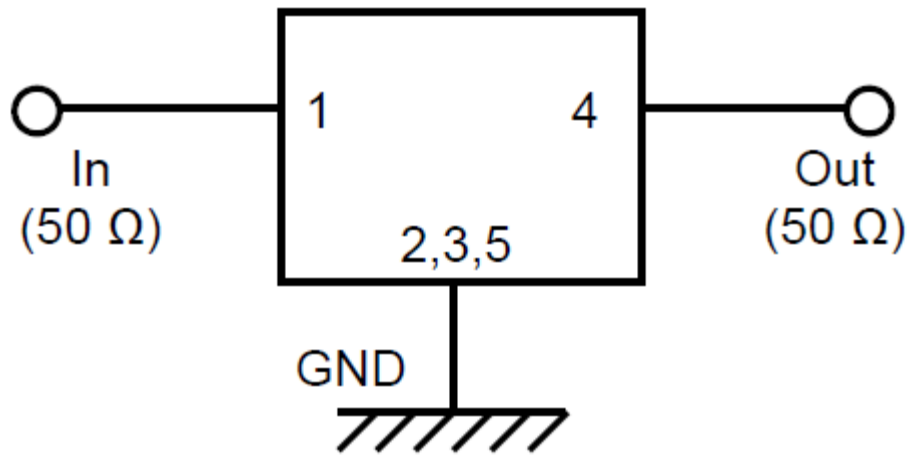

PCB Footprint

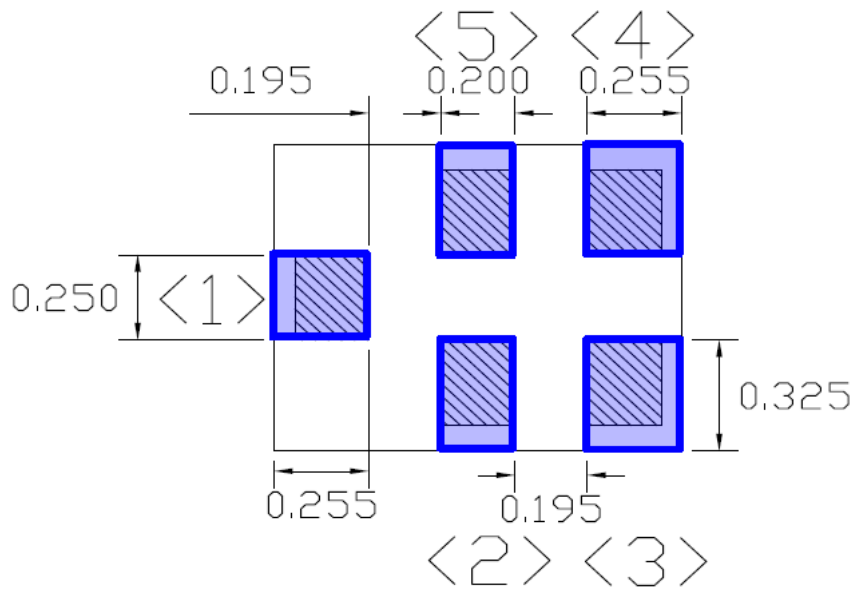

FREQUENCY CHARACTERISTICS

Passband

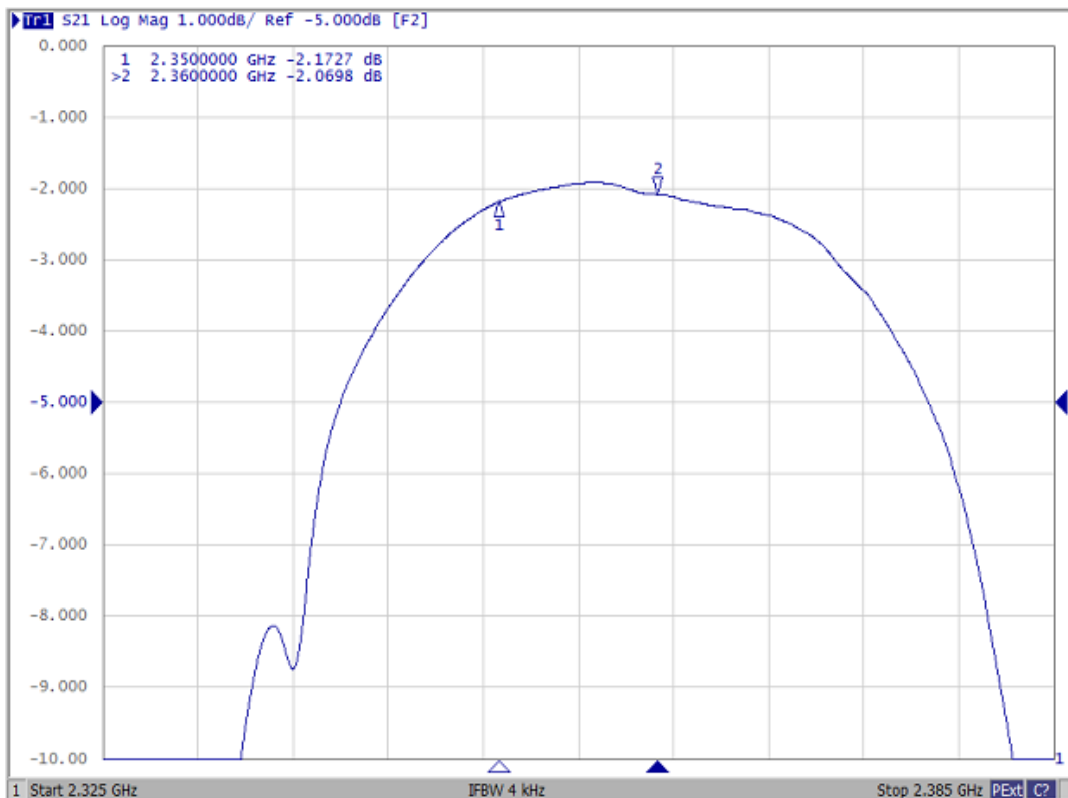
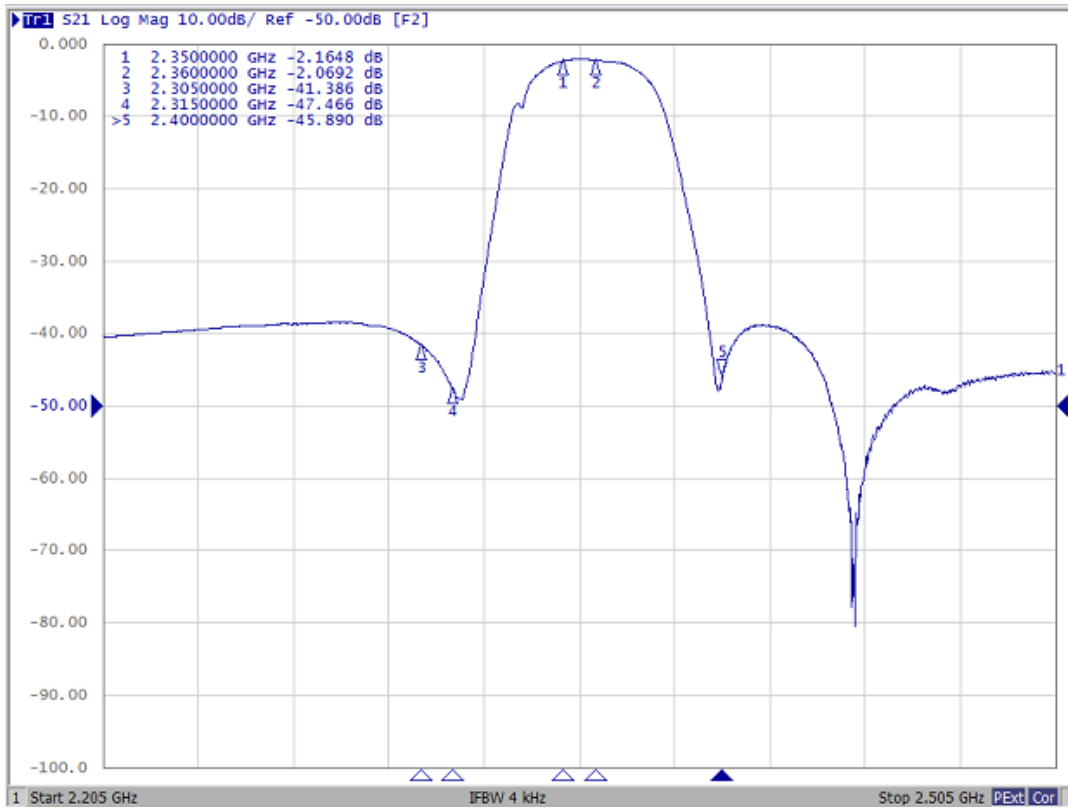

Wideband

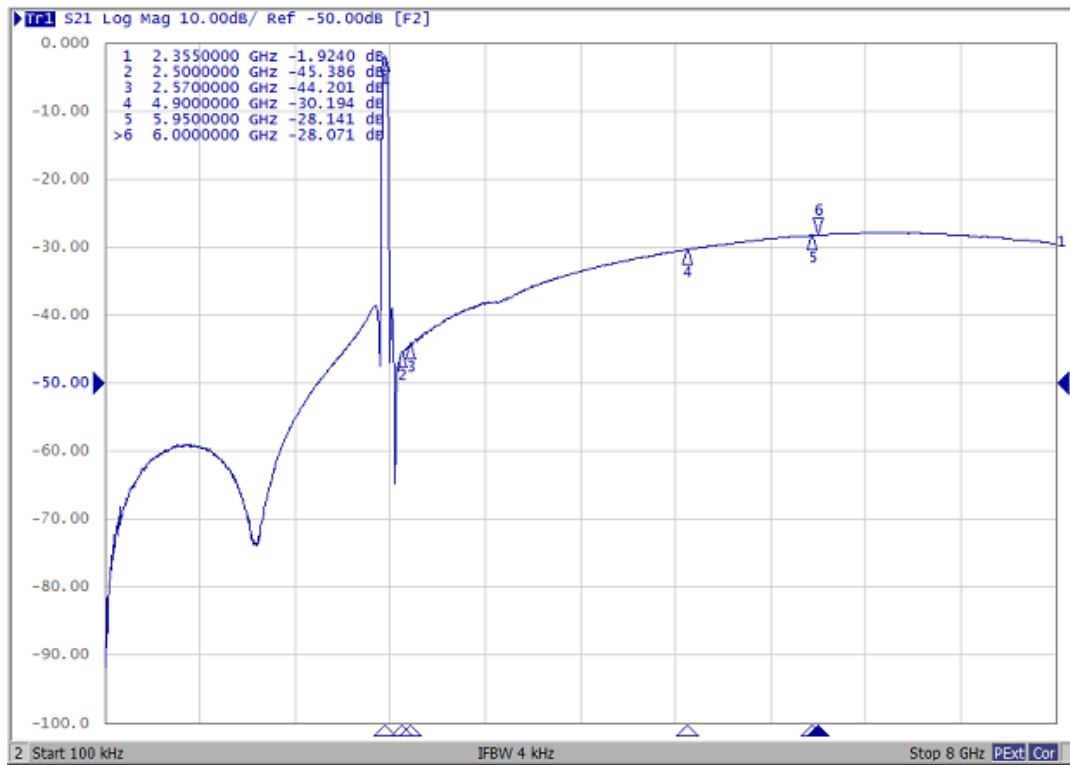

Reflection Functions

VSWR

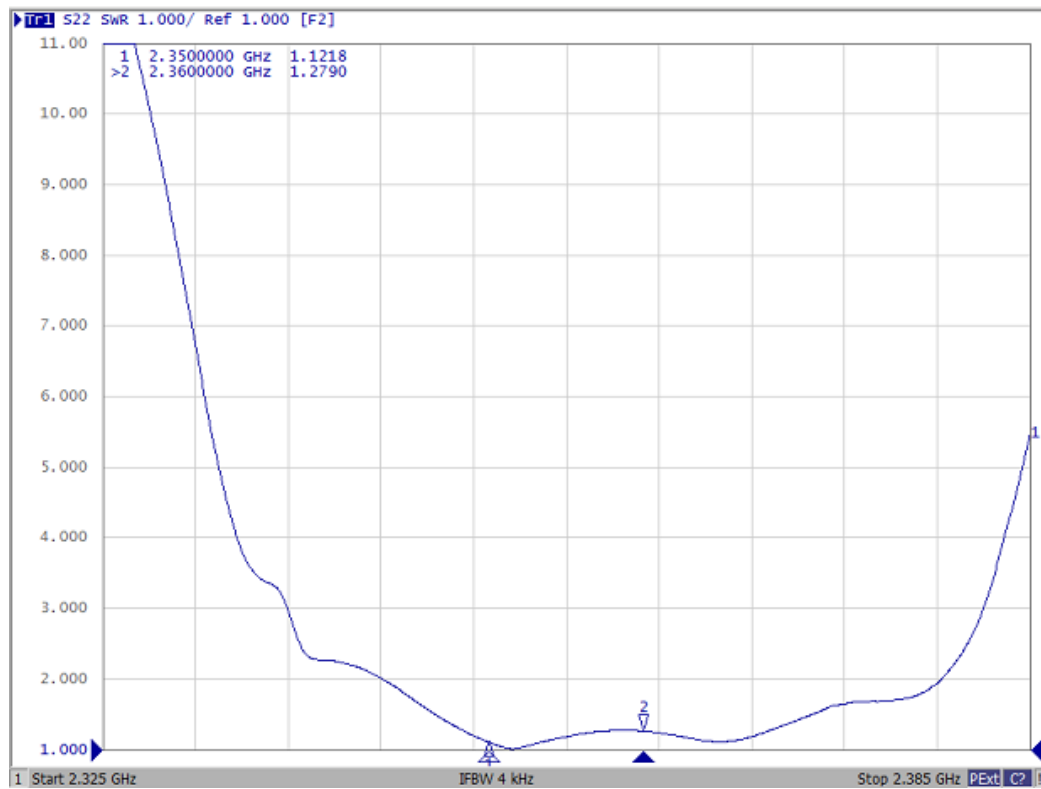
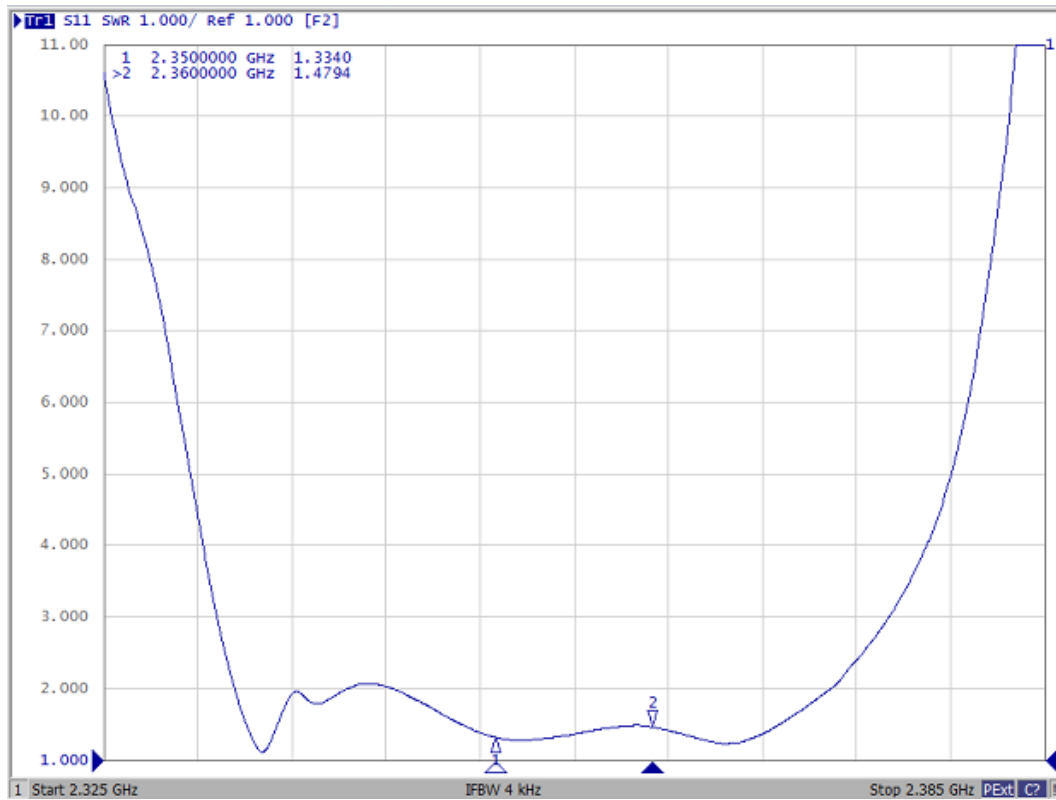

Smith Chart

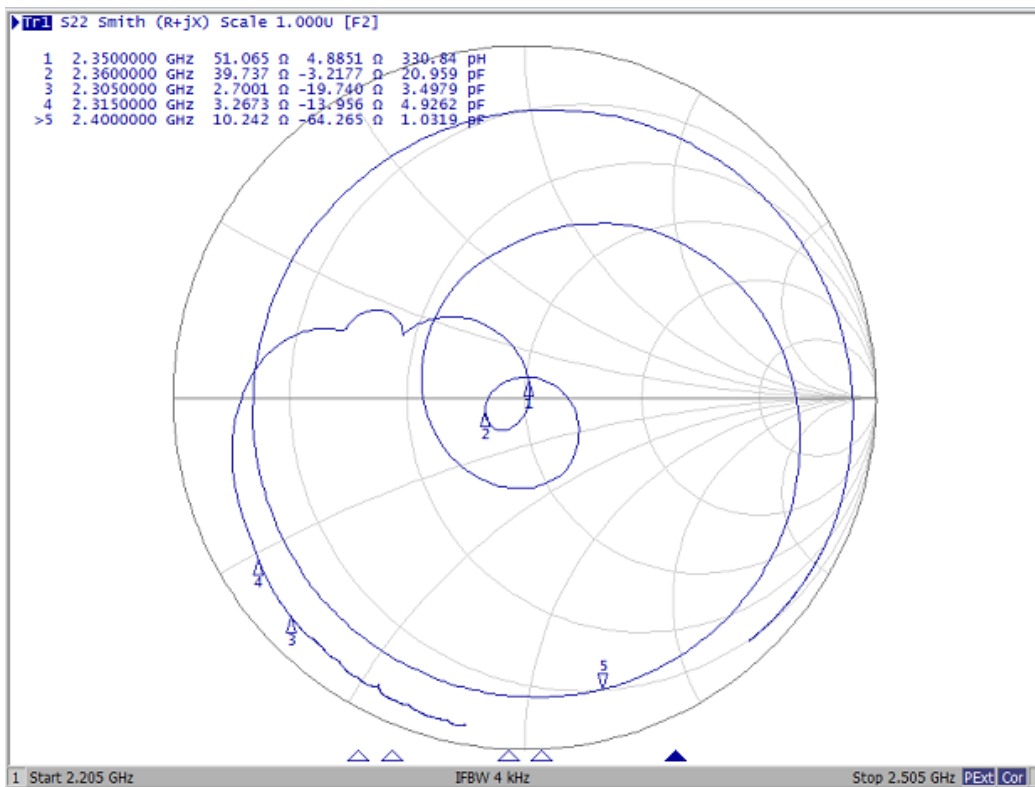
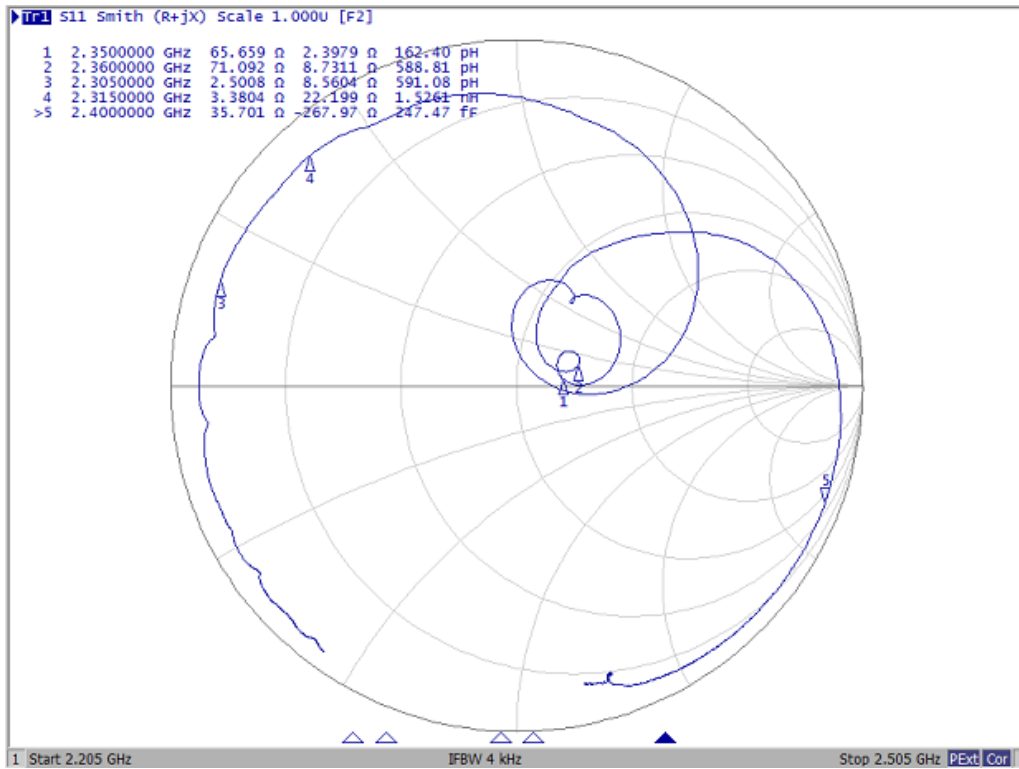

PACKING
REEL DIMENSION

Reel Count
7" = 3000
10" = 10,000

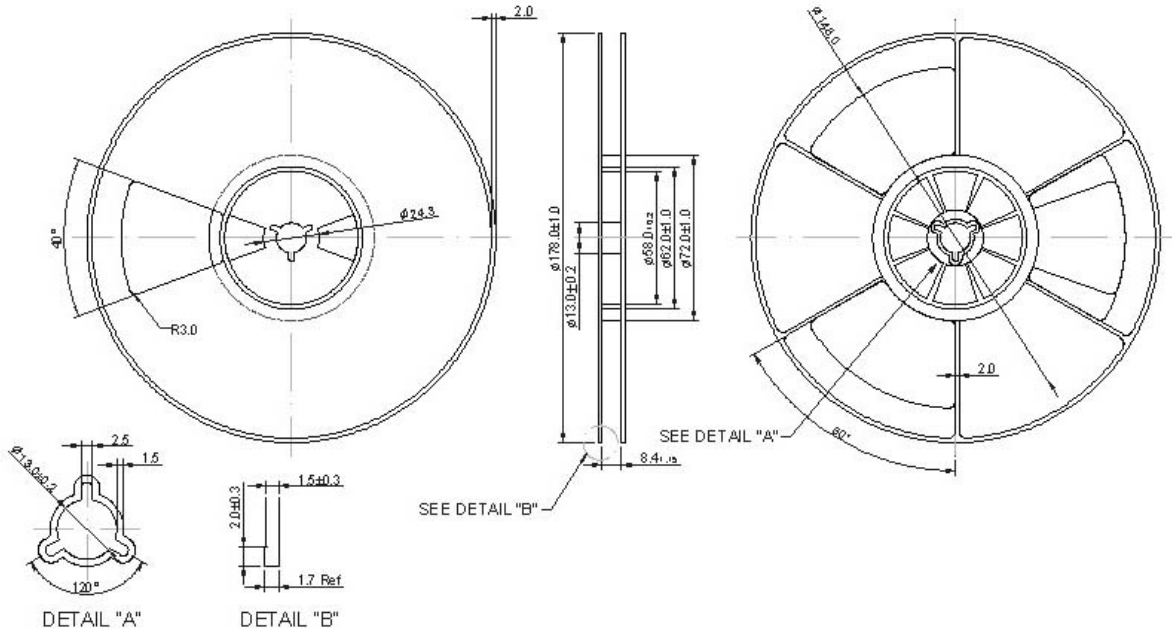

TAPE DIMENSION

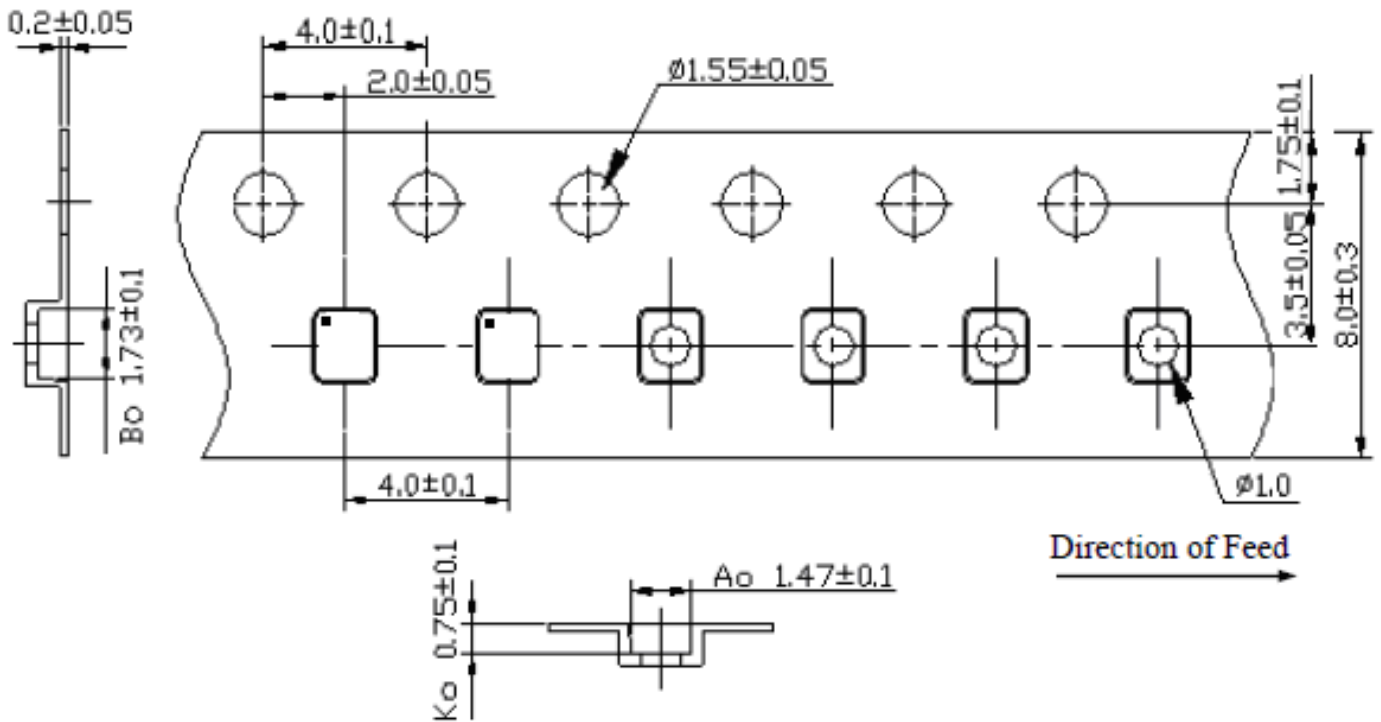

RECOMMENDED REFLOW PROFILE

1. Preheating shall be fixed at 150~180°C for 60~90 seconds.
2. Ascending time to preheating temperature 150°C shall be 30 seconds min.
3. Heating shall be fixed at 220°C for 50~80 seconds and at 245~260°C peak (min. 10sec).
4. Time : 2 times.

