

SM1814

MAXIMUM RATING:

- Operating temperature range: -30 °C to +85 °C
- Storage temperature range: -30 °C to +85 °C
- Input power : 29dBm (Ta=+50°C,50kh,CW)
- Maximum DC Voltage: +/-3 V
- Moisture Sensitivity Level: Level 1
- ESD 50V(MM) 100V(HBM)

ELECTRICAL CHARACTERISTICS:

Terminating impedance (Tx Port): 50 Ω (Single-ended)

Terminating impedance (Rx Port): 100+2.2nHx2 Ω (Balanced)

Terminating impedance (Ant Port): 50//4.3nH Ω (Single-ended)

Tx to ANT (f_{T0}=1880 MHz)

Parameters Description		Unit	Min	Typ	Max	Remarks
Insertion Loss	1850.48~1909.52MHz	dB(*1)	-	2.1	3.0	-20 to+85 °C
	1850.48~1909.52MHz (*2)	dB(*1)	-	2.0	2.7	-20 to+85 °C
	1850.625~1909.375MHz (*3)	dB(*1)	-	2.1	2.9	
Amplitude ripple	1850.48~1909.52MHz	dB	-	1.5	2.1	
VSWR	ANT	-	-	1.8	2.1	
	Tx	1850.48~1909.52MHz	-	-	1.6	2.0
Attenuation:						
1570~1580 MHz		dB	36	38	-	
1930.48~1989.52 MHz		dB	42	58	-	-20 to+85 °C
1930.48~1989.52 MHz (*2)		dB	45	59	-	-20 to+85 °C
1930.625~1989.375 MHz (*3)		dB	40	58	-	
3700~3820 MHz		dB	25	33	-	
5550~5730 MHz		dB	21	26		

 **CAUTION: Electrostatic Sensitive Device. Observe precautions for handling.**

NOTES:

1. The design, manufacturing process, and specifications of this device are subject to change.
2. US or International patents may apply.
3. RoHS compliant from the first date of manufacture.

ANT to Rx (f_{T0}=1960 MHz)

Parameters Description		Unit	Min	Typ	Max	Remarks
Insertion Loss	1930.48~1989.52MHz	dB(*1)		2.9	3.3	-20 to+85 °C
	1930.48~1989.52MHz (*2)	dB(*1)		2.5	3.0	-20 to+85 °C
	1930.625~1989.375MHz (*3)	dB(*1)		2.7	3.2	
Amplitude ripple	1930.48~1989.52MHz	dB		1.6	2.2	
Phase balance	1930.48~1989.52MHz	Deg	-12	-4/+3	12	
Amplitude balance	1930.48~1989.52MHz	dB	-1.3	-0.4/+0.6	1.3	
VSWR	ANT	1930.48~1989.52MHz		1.6	2.0	
	Rx			1.7	2.0	
Attenuation:						
1850.48~1909.52MHz		dB	47	50	-	-20 to+85 °C
1850.48~1909.52MHz (*2)		dB	47	52	-	-20 to+85 °C
1850.625~1909.375MHz (*3)		dB	47	50		

Tx to Rx

Isolation	1850.48~1909.52 MHz	dB	53	56	-	-20 to+85 °C
	1850.48~1909.52 MHz (*2)	dB	54	57	-	
		dB	53	57		
	1850.625~1909.375 MHz (*3)	dB	53	56		
	1930.48~1989.52 MHz	dB	47	55	-	-20 to+25 °C
		dB	50	55	-	+25 to+85 °C
	1930.48~1989.52 MHz (*2)	dB	50	56	-	-20 to+85 °C
	1930.625~1989.375 MHz (*2)	dB	45	55	-	-30 to+25 °C
dB		50	55	-	+25 to+85 °C	

(*1) Specification of insertion loss excludes loss that comes from the test board.

(*2) The integrated loss over any 3.84MHz(+/- 1.92MHz) channel within the band.

(*3) The integrated loss over any 1.25MHz(+/- 0.625MHz) channel within the band.

Evaluation Circuit

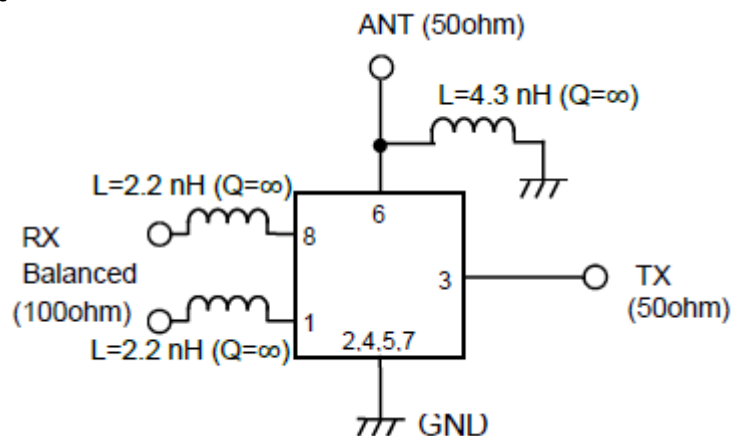

FREQUENCY CHARACTERISTICS:

Tx to Ant

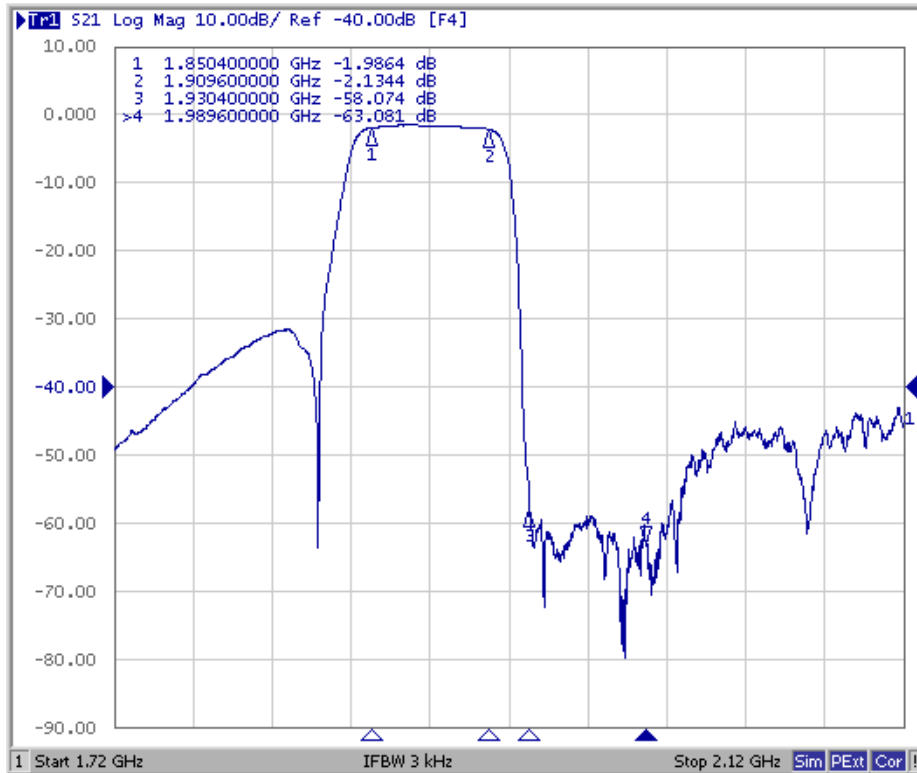

Ant to Rx

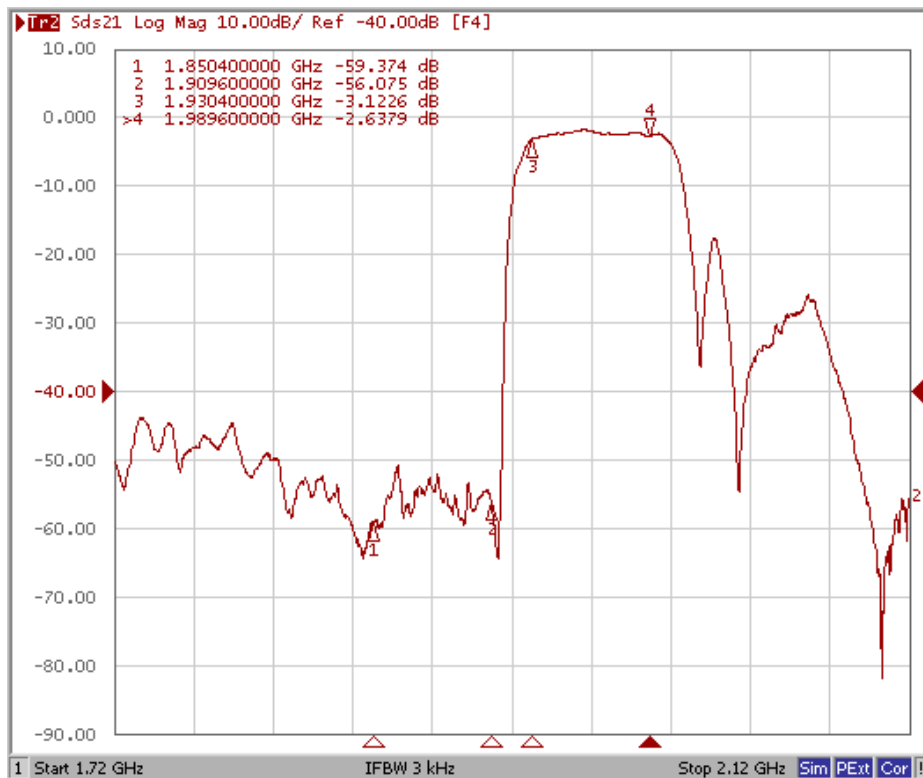

These data exclude loss that comes from the test board.

Tx to Ant ,Ant to Rx

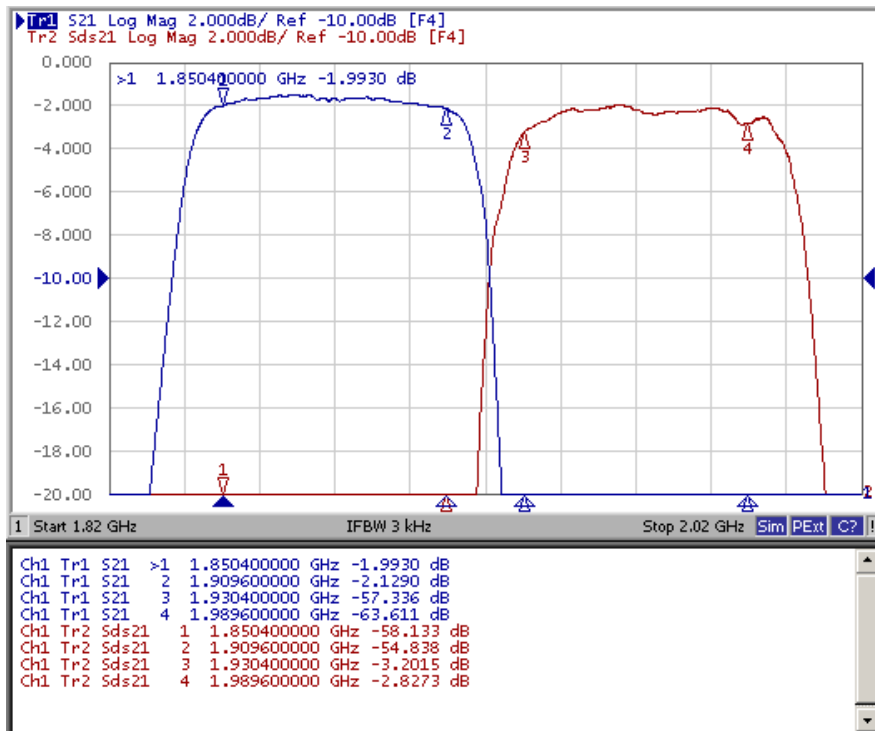

Tx to Rx Isolation

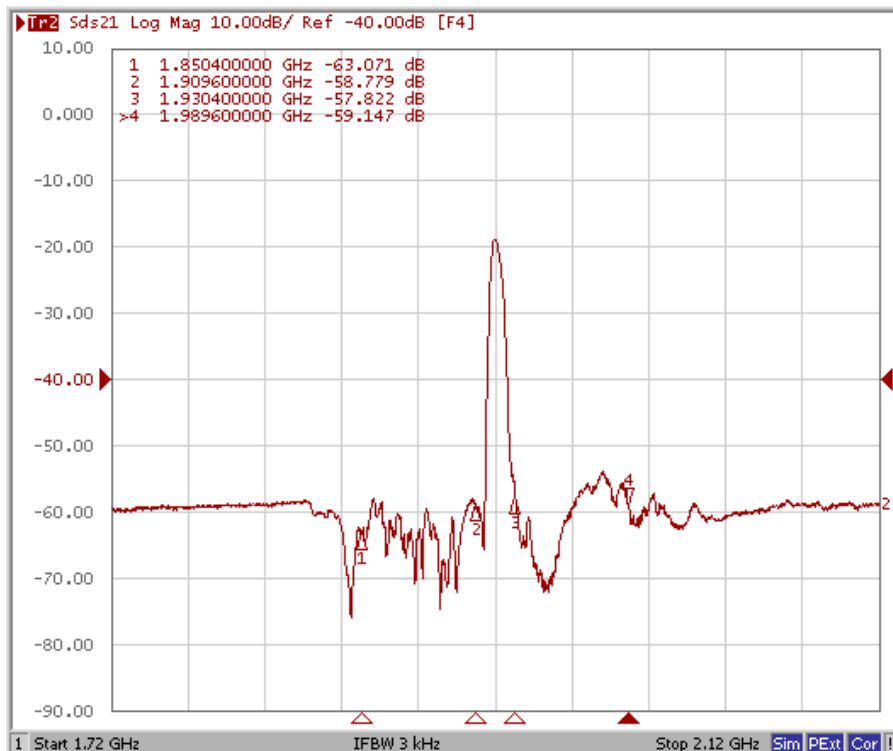

These data exclude loss that comes from the test board

Tx Port

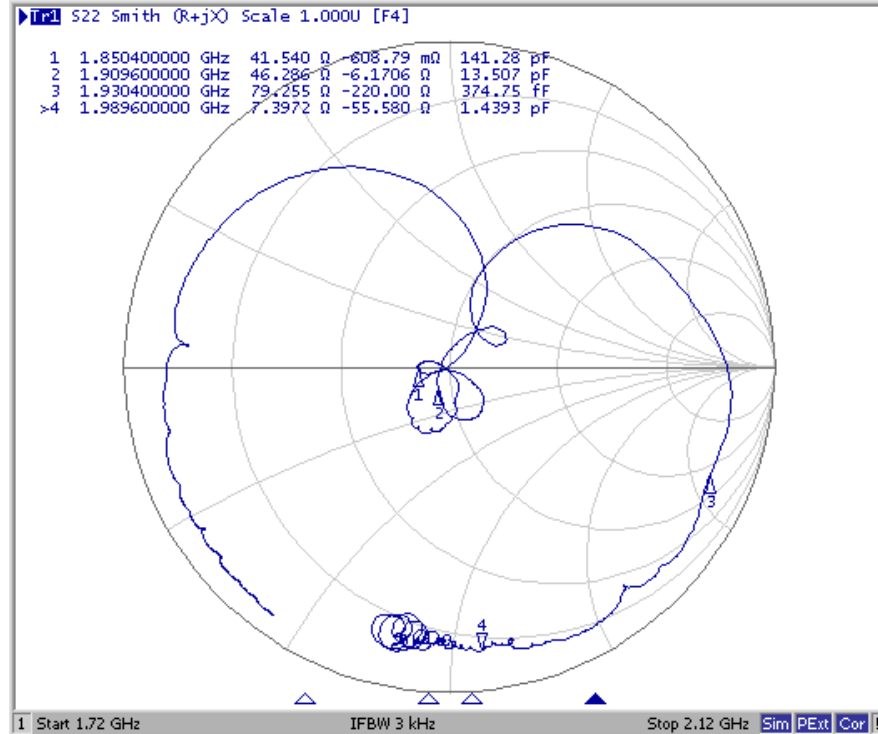
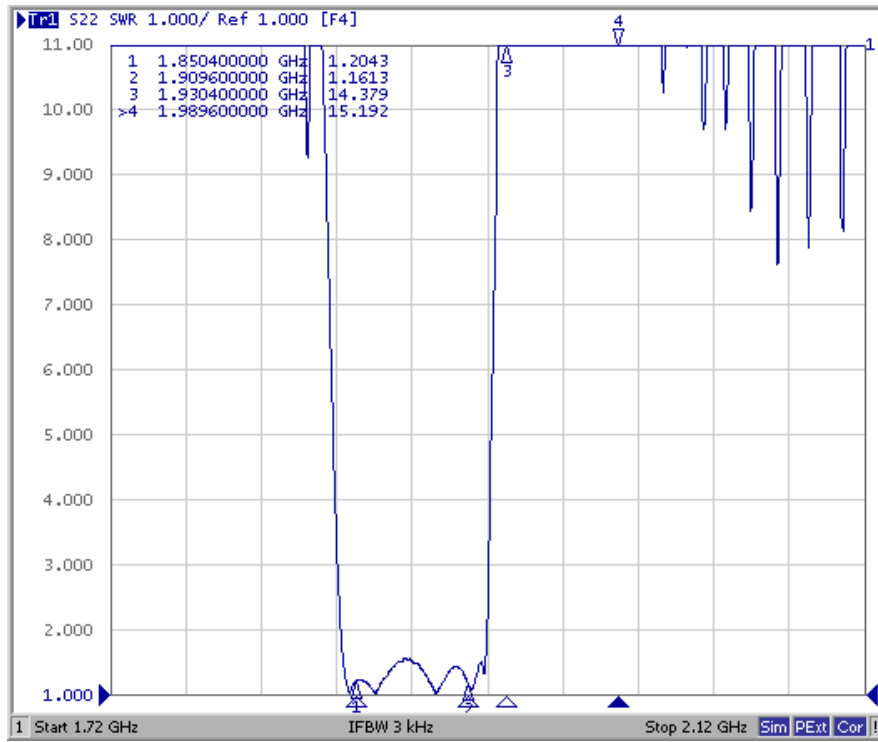

Rx Port

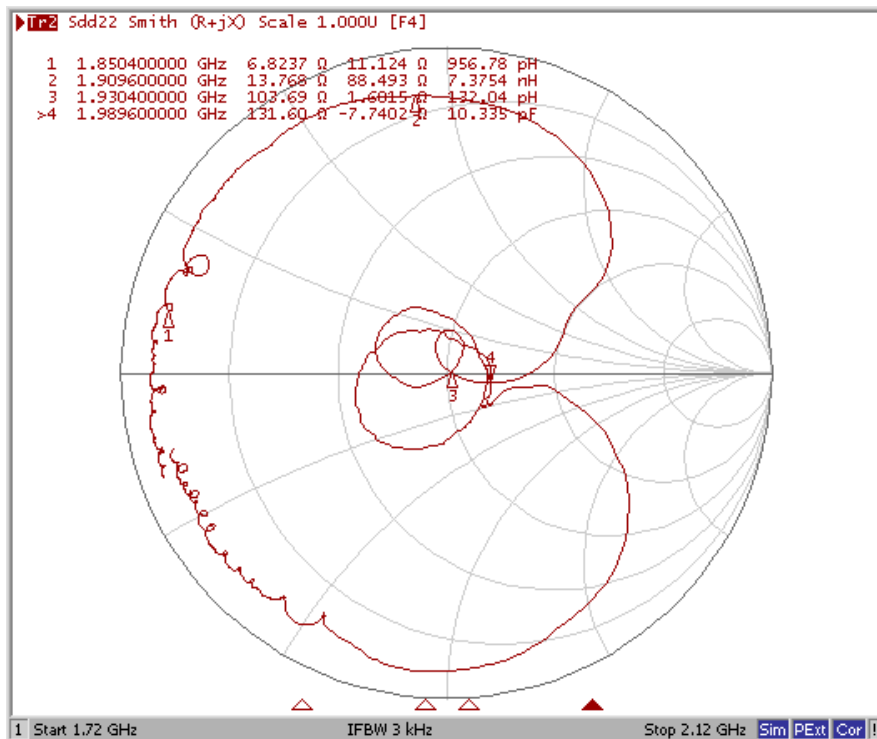
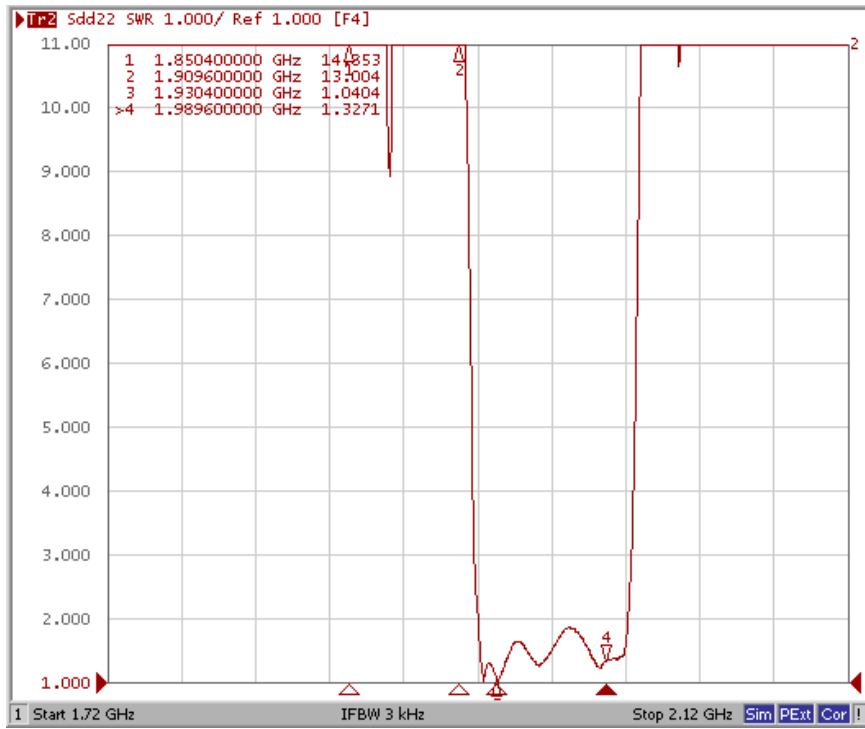

Ant Port

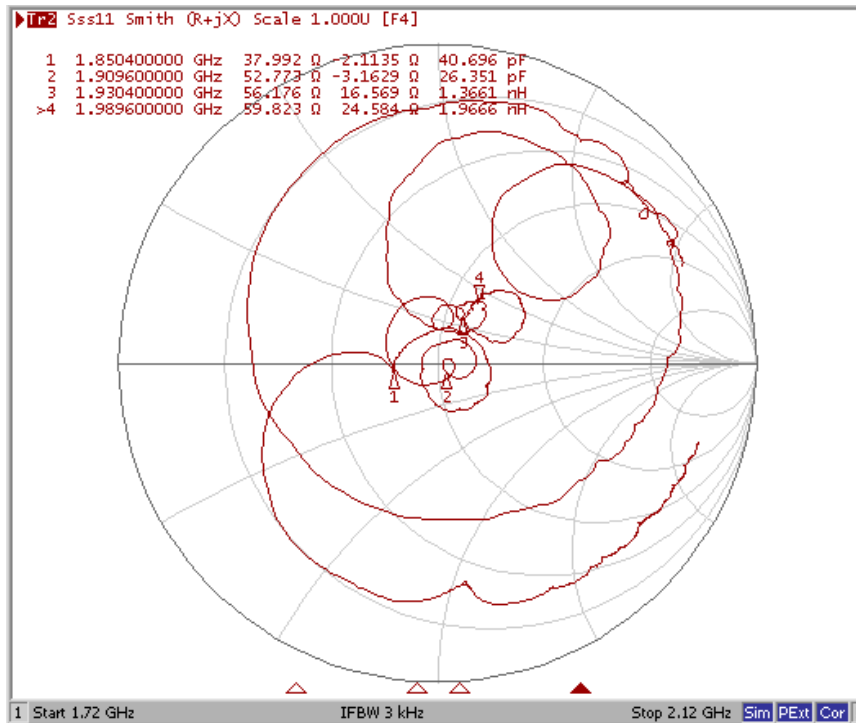
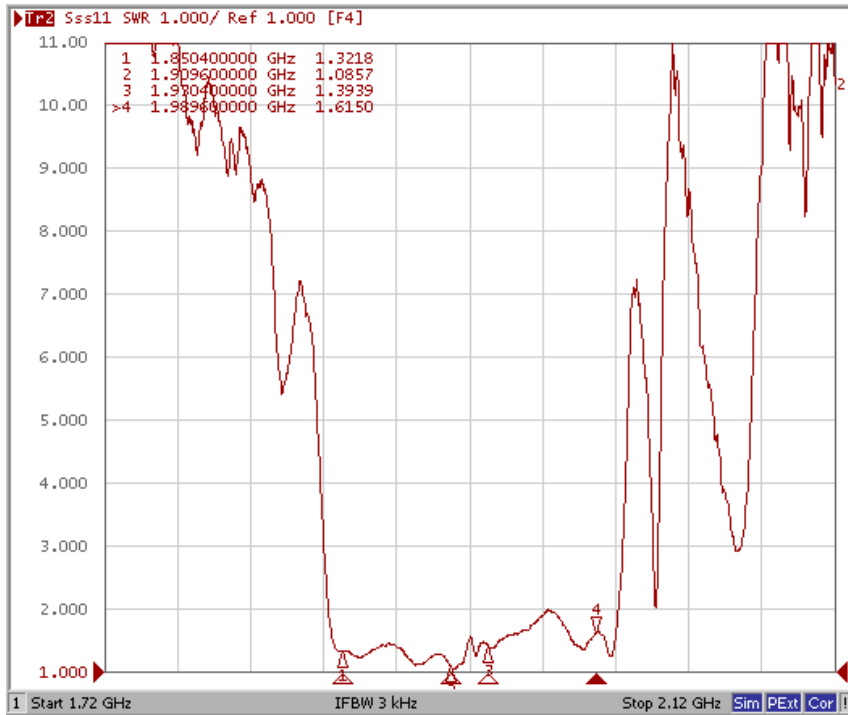

Ant to Rx (Amplitude balance)

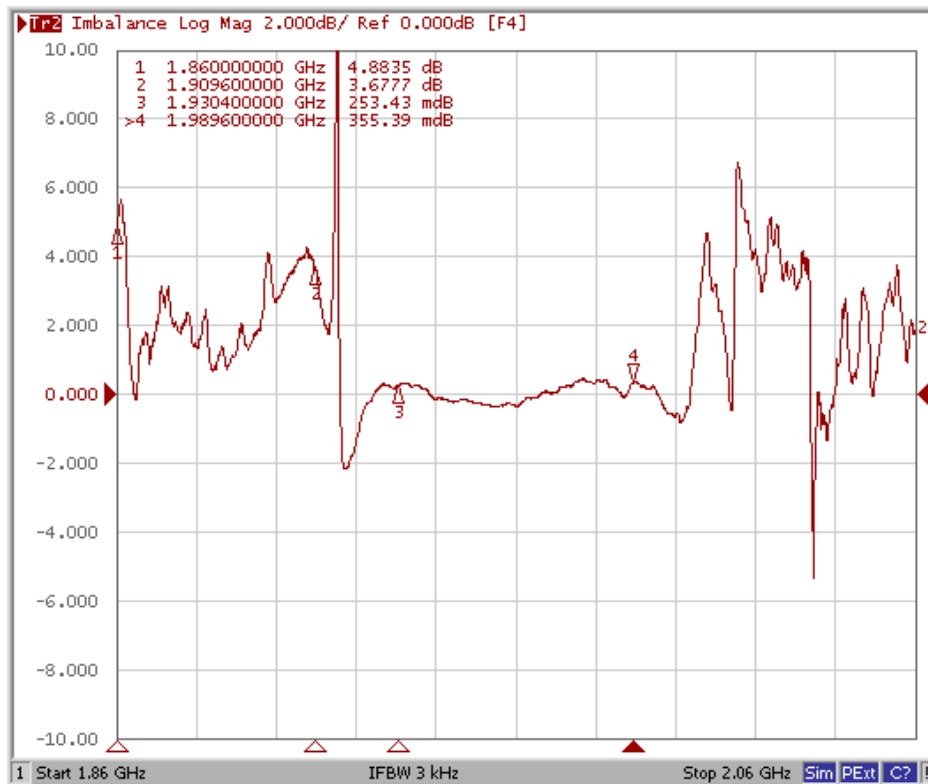

Ant to Rx (Phase balance)

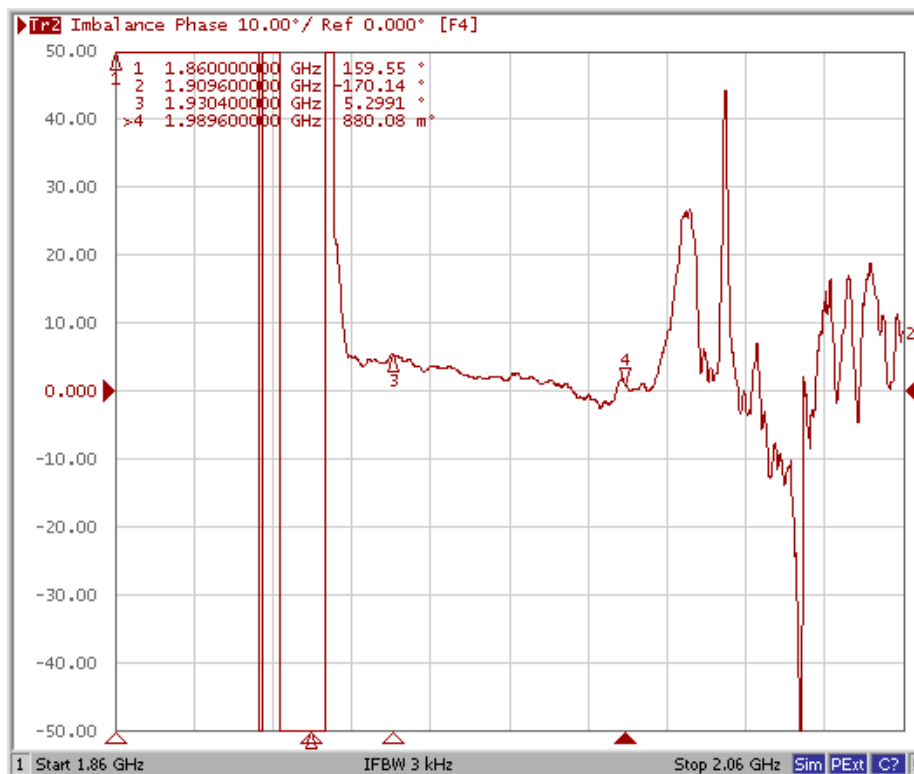

Tx to Ant (Wide span)

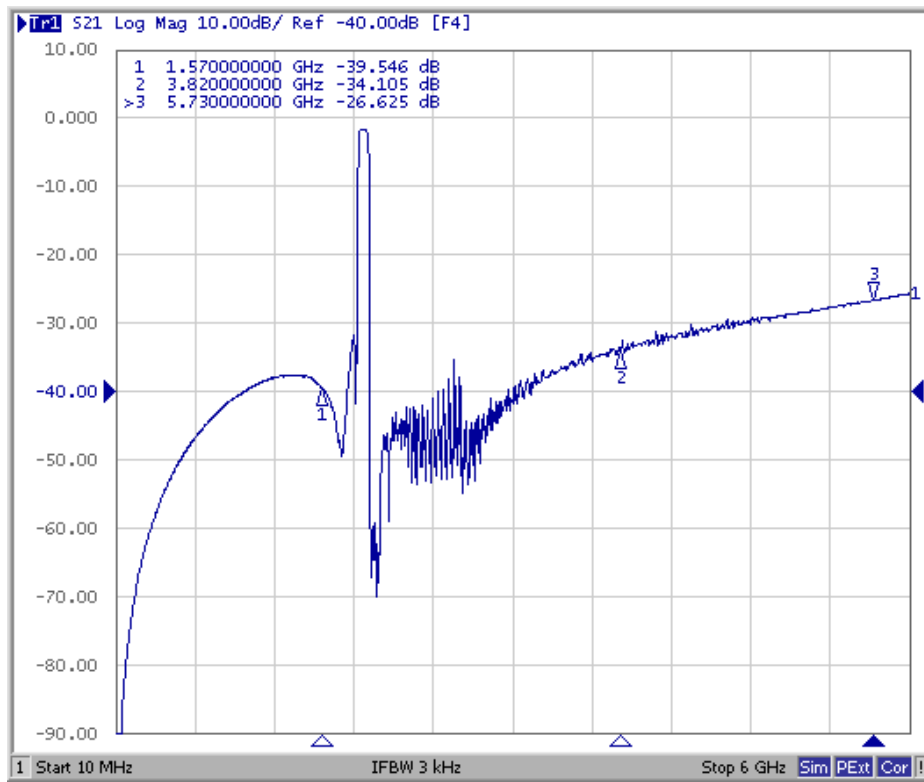

Ant to Rx (Wide span)

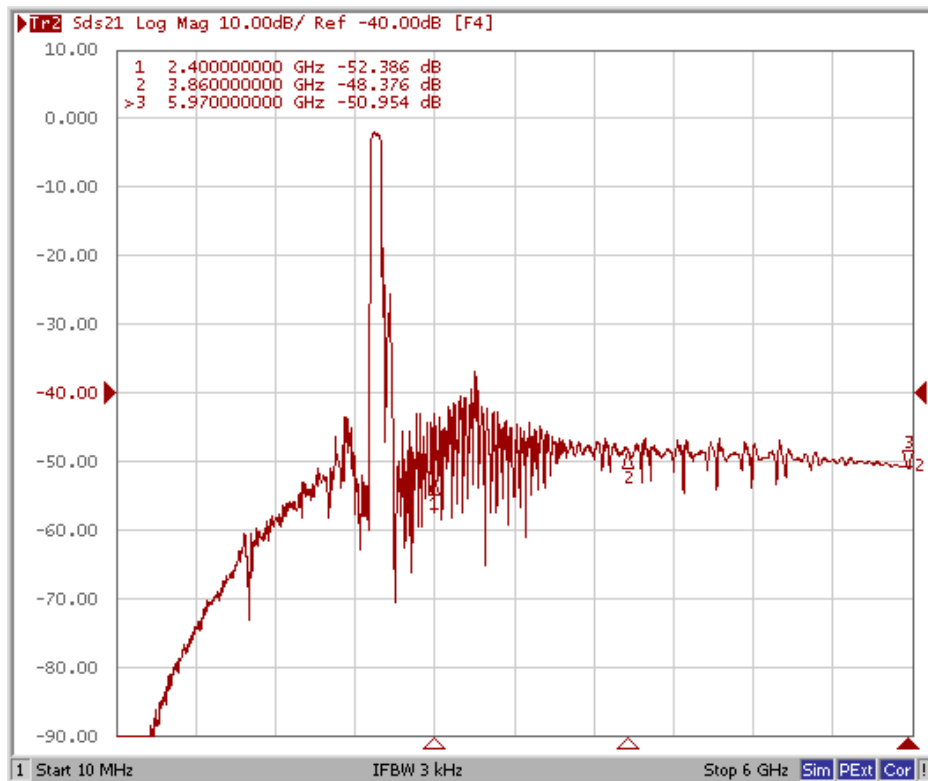

OUTLINE DRAWING:

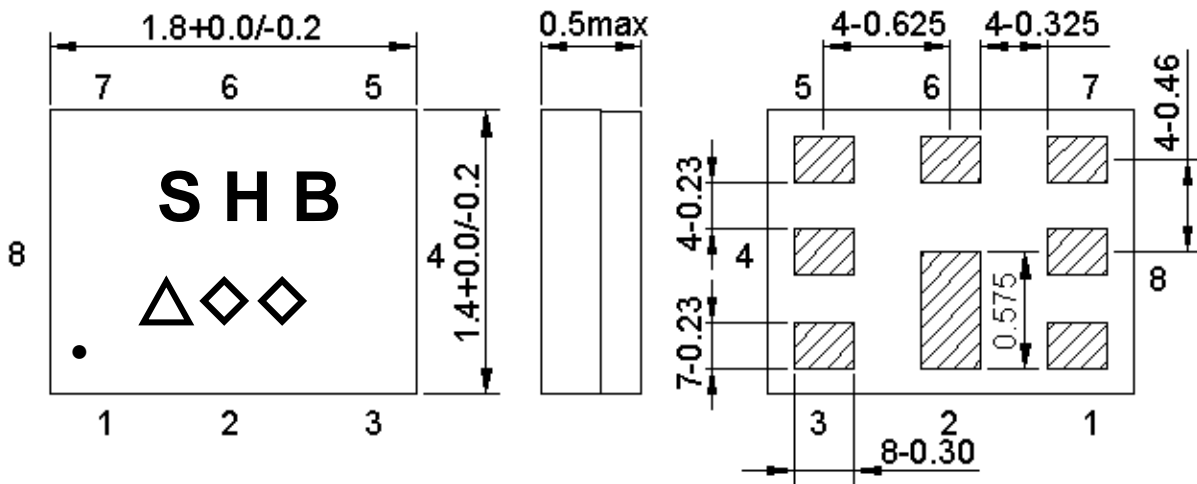

Marking name : **SHB**

△: Date code(2016 May → s ,....., 2019 Dec→m.)

◇◇: Lot Code.

Product Date Code. Follow below table.

Year	Jan	Feb	Mar	Apr	May	Jun	Jul	Aug	Sep	Oct	Nov	Dec
2016	n	p	q	r	s	t	u	v	w	x	y	z
2017	A	B	C	D	E	F	G	H	J	K	L	M
2018	N	P	Q	R	S	T	U	V	W	X	Y	Z
2019	a	b	c	d	e	f	g	h	j	k	l	m

Pin Configuration:

Pin No.	Pin Name	Description
1	Rx	Receive Pin
2	GND	Ground Pin
3	Tx	Transmitter Pin
4	GND	Ground Pin
5	GND	Ground Pin
6	ANT	Antenna Pin
7	GND	Ground Pin
8	GND	Ground Pin

FOOTPRINT:

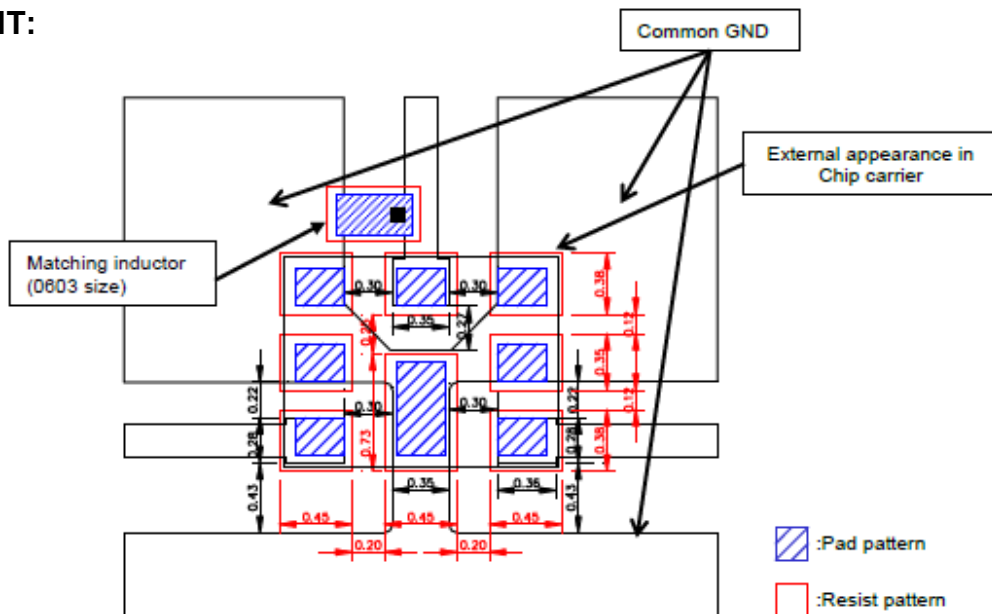

PACKING:
REEL DIMENSION

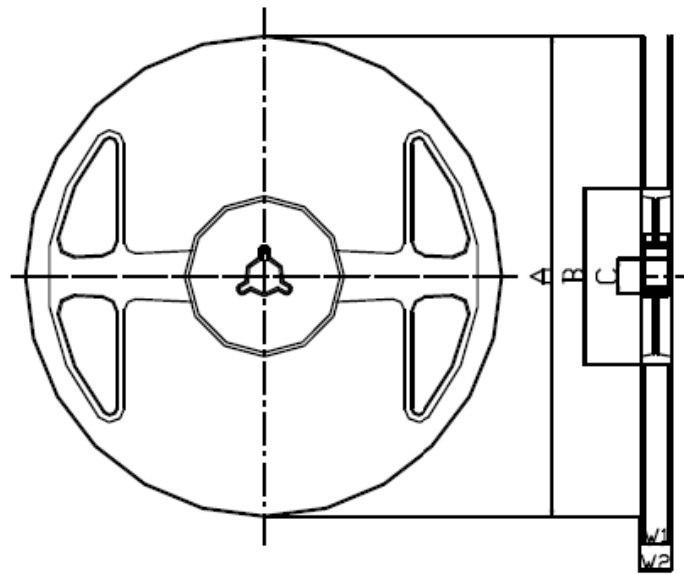

Reel Count:
7" = 3000
13" = 10,000

Materials of Reel

Material : Polystyrene + Carbon
 Characteristics : Conforms to EIAJ-ET-7200A
 Color : Black
 Surface resistance (reference value) : $10^9\Omega/\text{sq}$ Max.

Unit : mm

Code	Quantity	A	B	C	W1	W2
Z	3,000 pcs	$\phi 180.0 +0.0/-1.5$	$\phi 66.0 +/-0.5$	$\phi 13.0 +/-0.2$	$9.0 +1.0/-0.0$	$11.4 +/-1.0$

TAPE DIMENSION

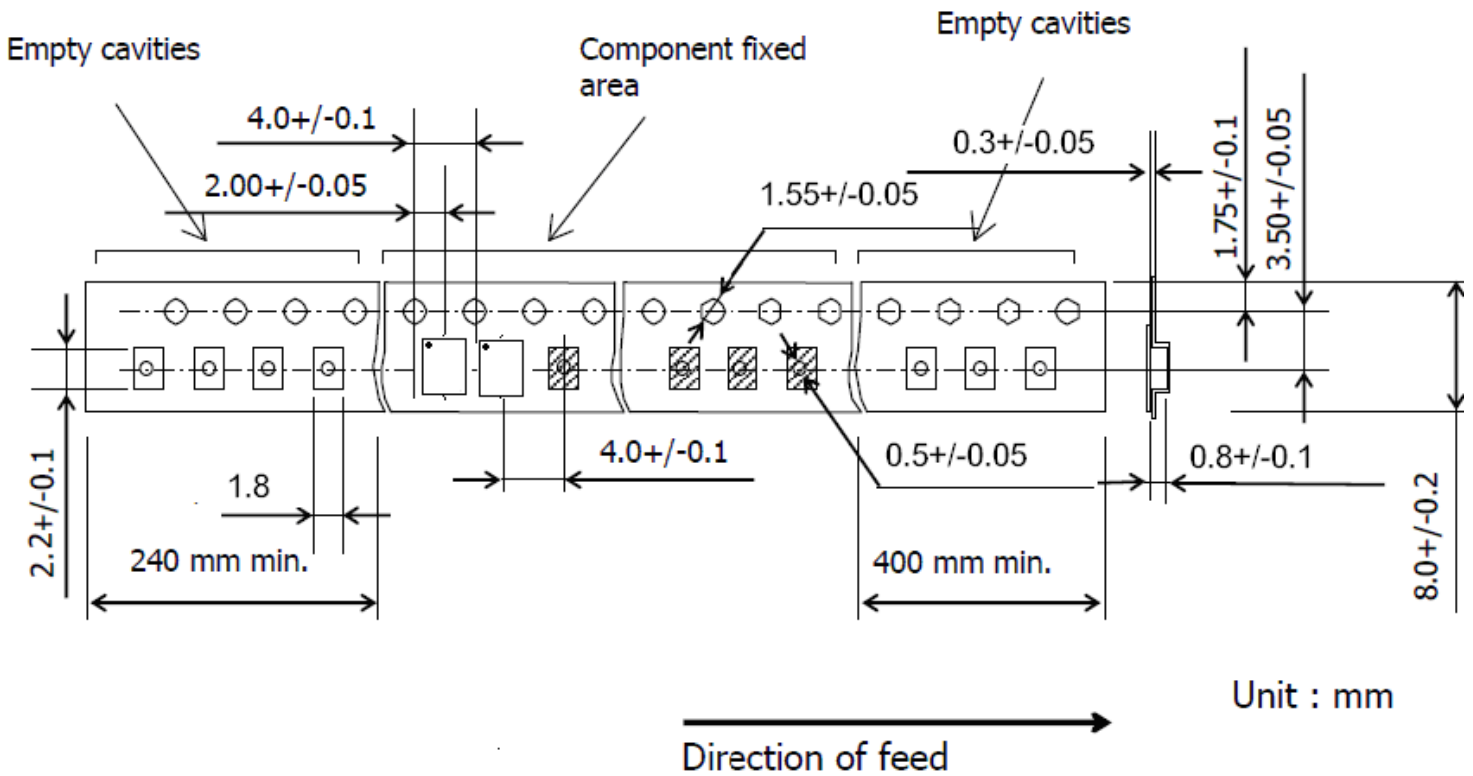

Unit : mm

RECOMMENDED REFLOW PROFILE :

1. Preheating shall be fixed at 150~180°C for 60~90 seconds.
2. Ascending time to preheating temperature 150°C shall be 30 seconds min.
3. Heating shall be fixed at 220°C for 50~80 seconds and at 245~260°C peak (min. 10sec).
4. Time : 2 times.

