

SF2648LM

**847 MHz
SAW Filter**



SM1109-5

MAXIMUM RATING:

- Operating temperature range: -30 °C to +85 °C
- Storage temperature range: -40 °C to +100 °C
- Input power : 10dBm
- Maximum DC Voltage: +/-5 V
- Moisture Sensitivity Level: Level 1 (MSL 1)
- ESD 100V(MM) 200V(HBM)

ELECTRICAL CHARACTERISTICS:

Terminating source impedance : $Z_s = 50 \Omega$

Terminating load impedance : $Z_L = 50 \Omega$

Parameters Description		Unit	Min	Typ	Max	Remarks	
Insertion Loss	832~ 862MHz	dB(*1)	-	2.0	2.5		
Amplitude ripple	832~ 862MHz	dB	-	0.9	1.6		
VSWR	Input	832~ 862MHz	-	-	2.3	2.5	
	Output	832~ 862MHz	-	-	2.3	2.5	
Attenuation:							
DC ~ 791 MHz		dB	30	55	-		
791 ~ 821 MHz		dB	40	48	-		
925 ~ 960 MHz		dB	20	50	-		
1565.42 ~ 1573.374 MHz		dB	35	47	-		
1573.374 ~ 1577.466 MHz		dB	35	47	-		
1577.466 ~ 1585.42 MHz		dB	35	46	-		
1597.5515 ~ 1605.886 MHz		dB	35	46	-		
1664 ~ 1724 MHz		dB	25	45	-		
1805 ~ 1880 MHz		dB	25	44	-		
2110 ~ 2170 MHz		dB	25	42	-		
2400 ~ 2500 MHz		dB	30	41	-		
2496 ~ 2586 MHz		dB	30	40	-		
2570 ~ 2620 MHz		dB	30	40	-		
2620 ~ 2690 MHz		dB	25	39	-		
3328 ~ 3448 MHz		dB	20	37	-		
Input impedance		Ω	50			single-ended	
Output impedance		Ω	50			single-ended	

(*1) Specification of insertion loss includes loss that comes from the test board.(0.05dB)



CAUTION: Electrostatic Sensitive Device. Observe precautions for handling.

NOTES:

1. The design, manufacturing process, and specifications of this device are subject to change.
2. US or International patents may apply.
3. RoHS compliant from the first date of manufacture.

FREQUENCY CHARACTERISTICS:

Passband

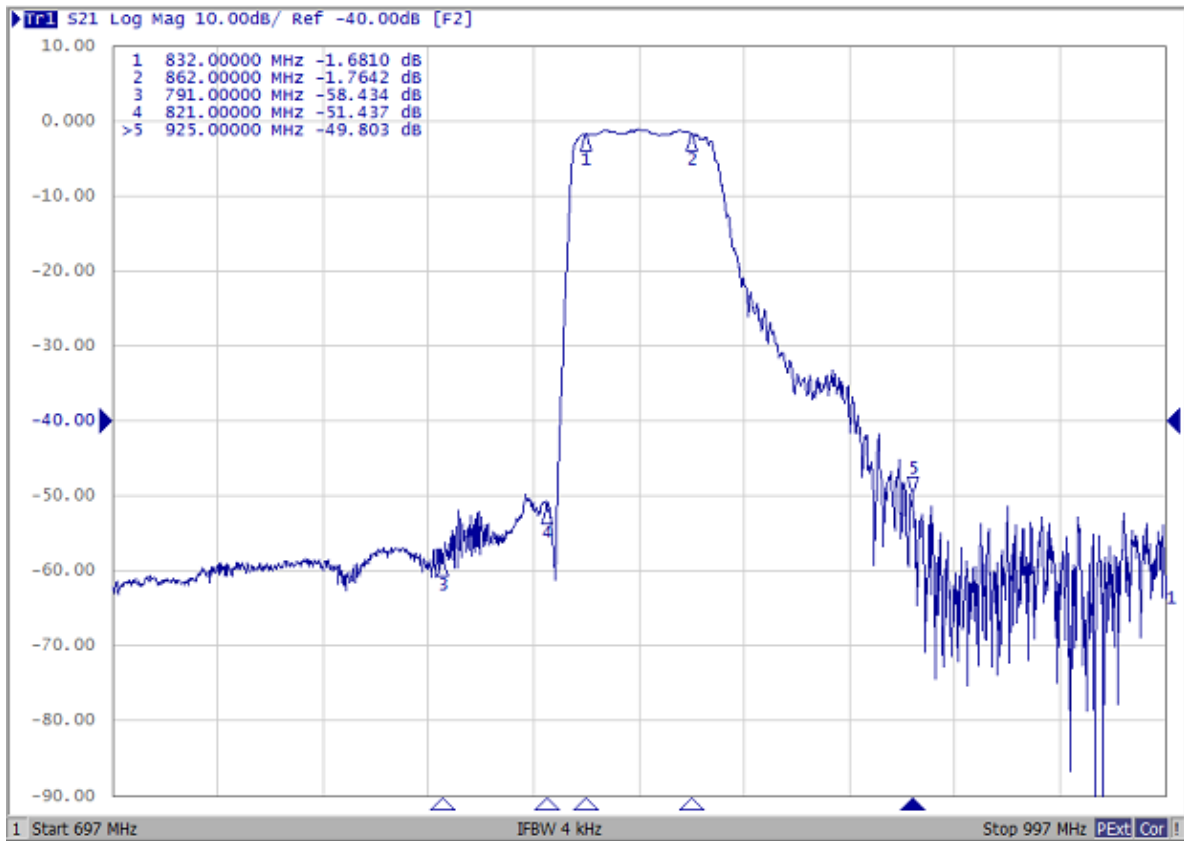

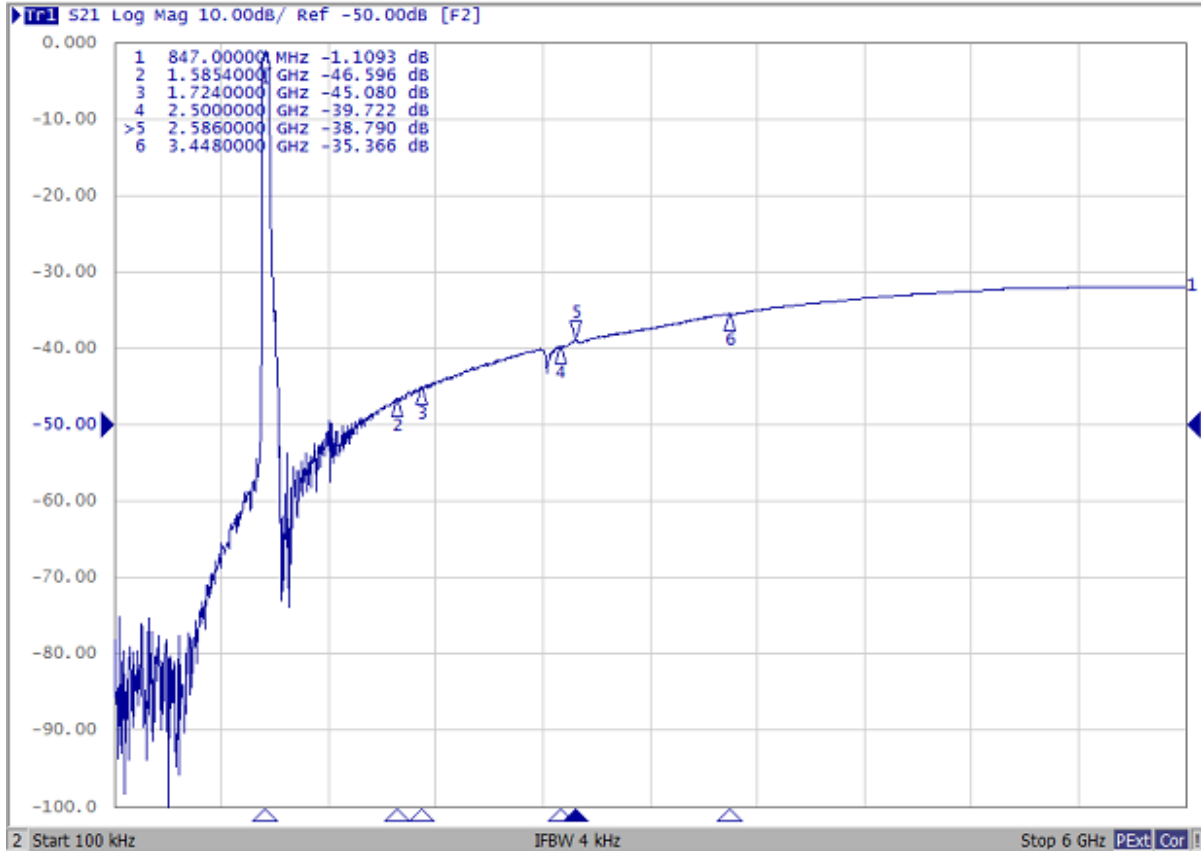
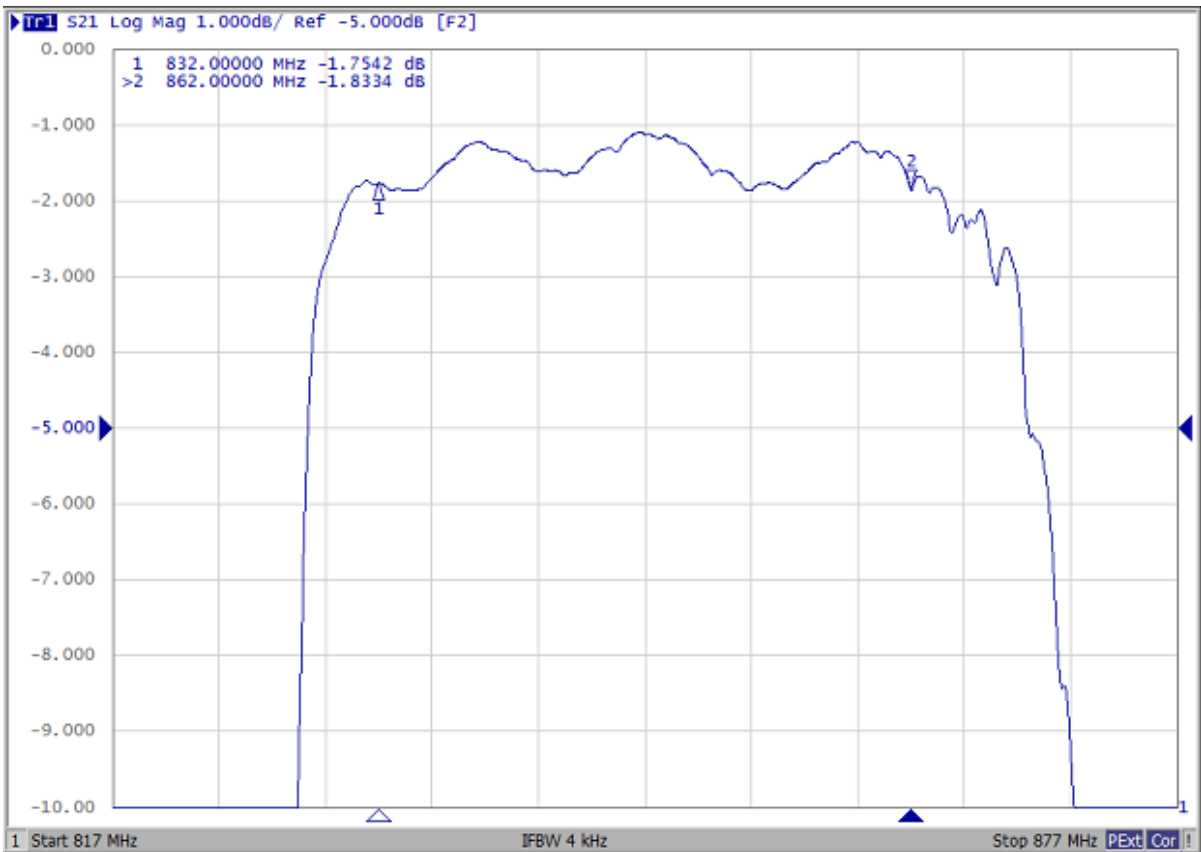

Reflection Functions :

S11 VSWR

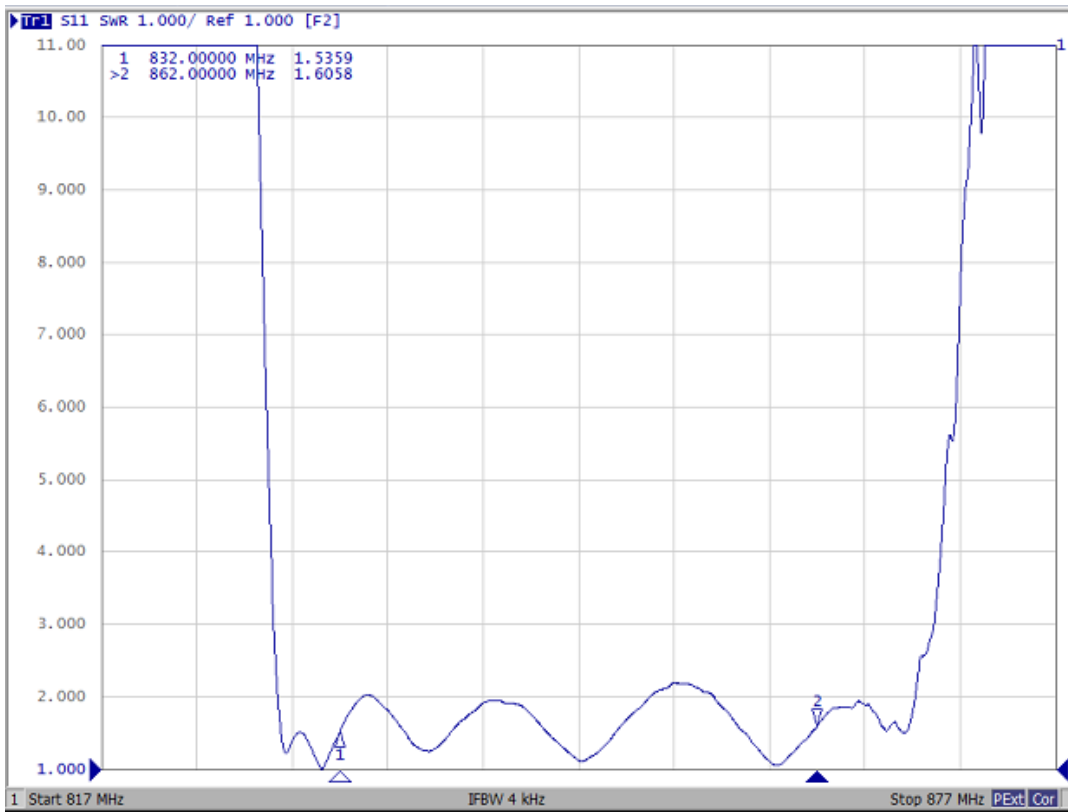

S22 VSWR

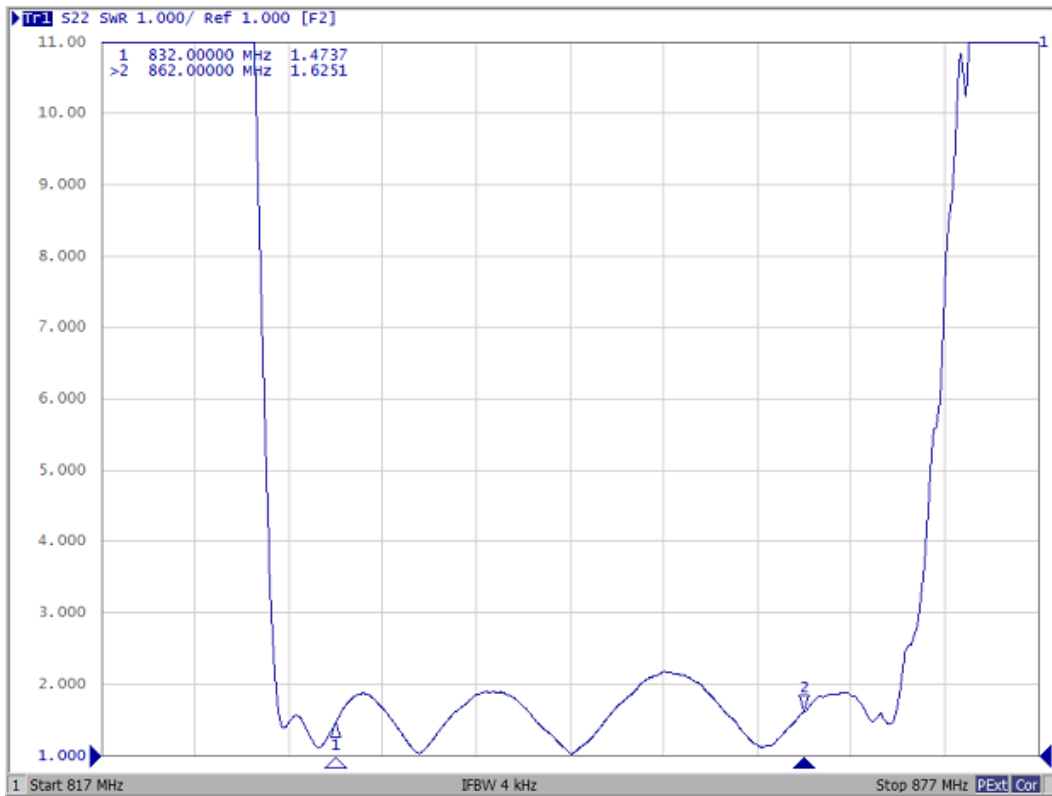

S11 Smith Chart

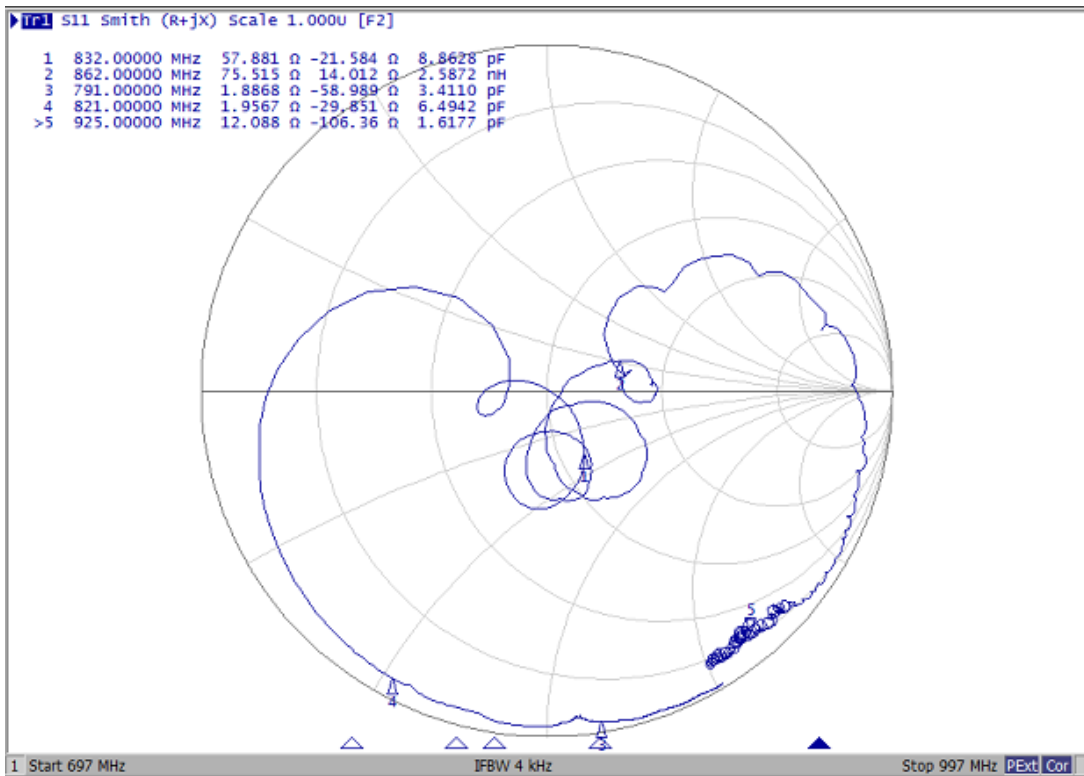

S22 Smith Chart

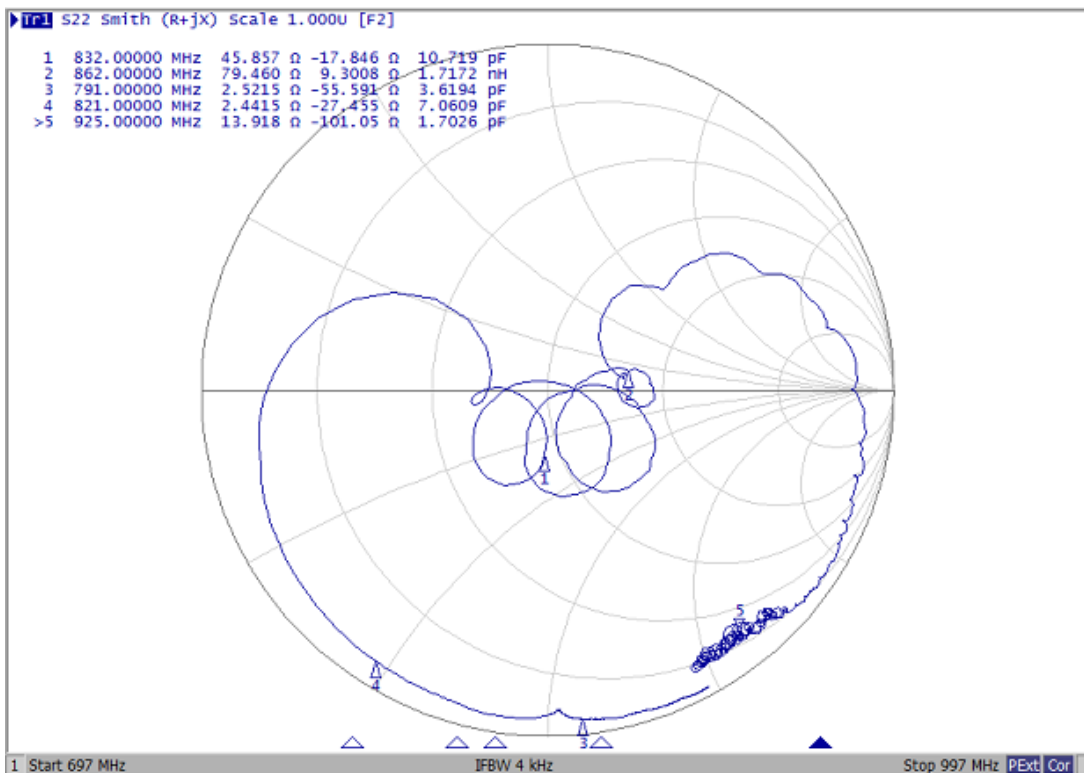

OUTLINE DRAWIN:

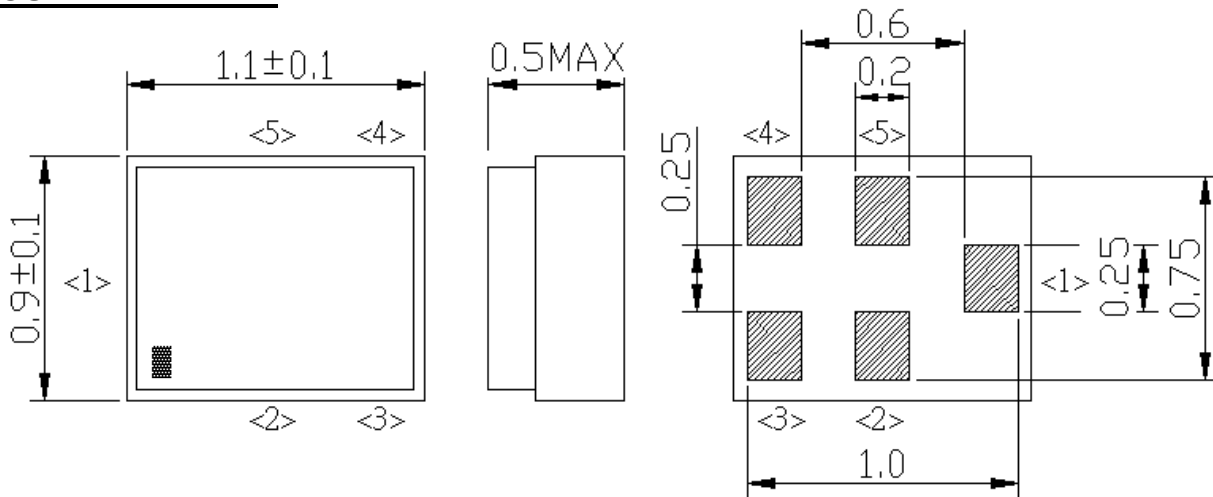

Unit: mm
Not Specified Tolerance : +/-0.1 mm

Pin Configuration

Pin No.	Symbol	Function
1	IN	Single-ended pin
2	GND	Ground
3	GND	Ground
4	OUT	Single-ended pin
5	GND	Ground

Top View (Sample Production):



Top View (Mass Production):

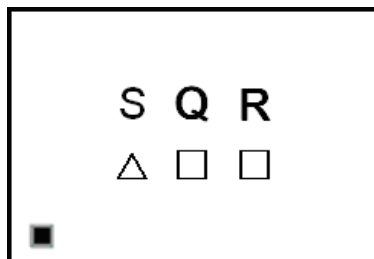

△ : Date Code

□ : Lot No. (Indicated by 0~9 or A to Z and a to z, except I, O, i, o and l)

Date Code: Follow below table. (4-year cycle)

Year	Jan.	Feb.	Mar.	Apr.	May	Jun.	Jul.	Aug.	Sep.	Oct.	Nov.	Dec.
2018	N	P	Q	R	S	T	U	V	W	X	Y	Z
2019	a	b	c	d	e	f	g	h	j	k	l	m
2020	n	p	q	r	s	t	u	v	w	x	y	z
2021	A	B	C	Đ	E	F	G	H	J	K	L	M

Evaluation Circuit

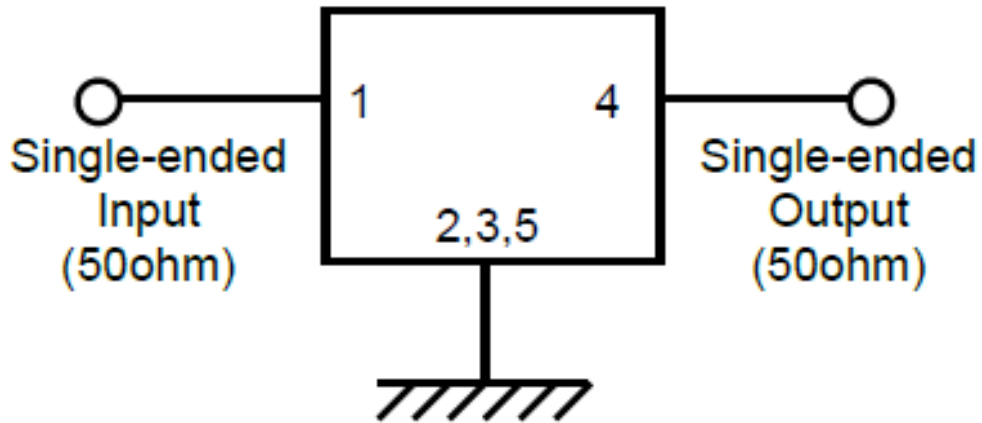

PCB Footprint :

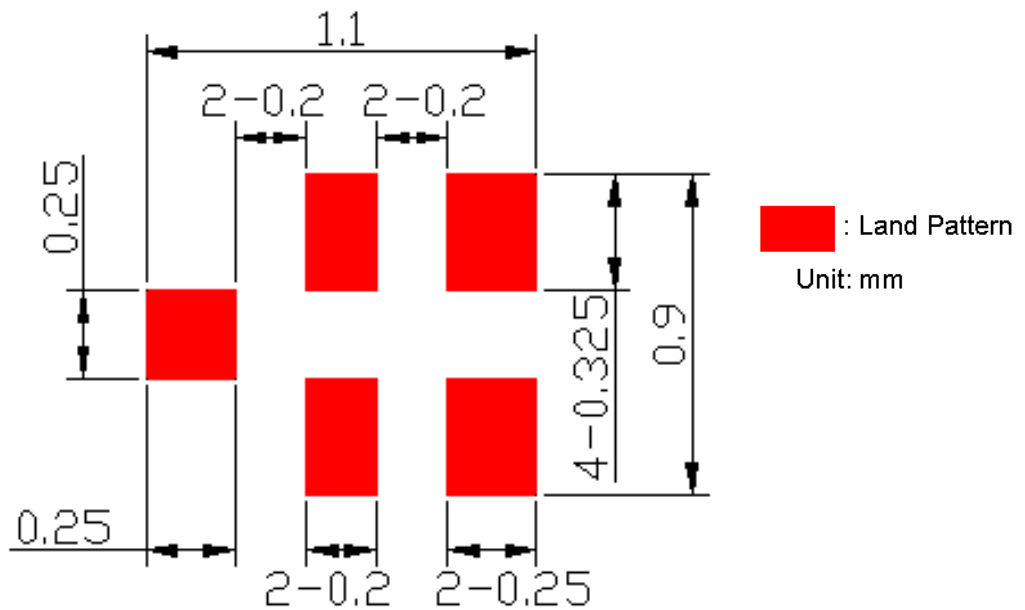

PACKING:

Reel Count: 7" = 3000

1. REEL DIMENSION

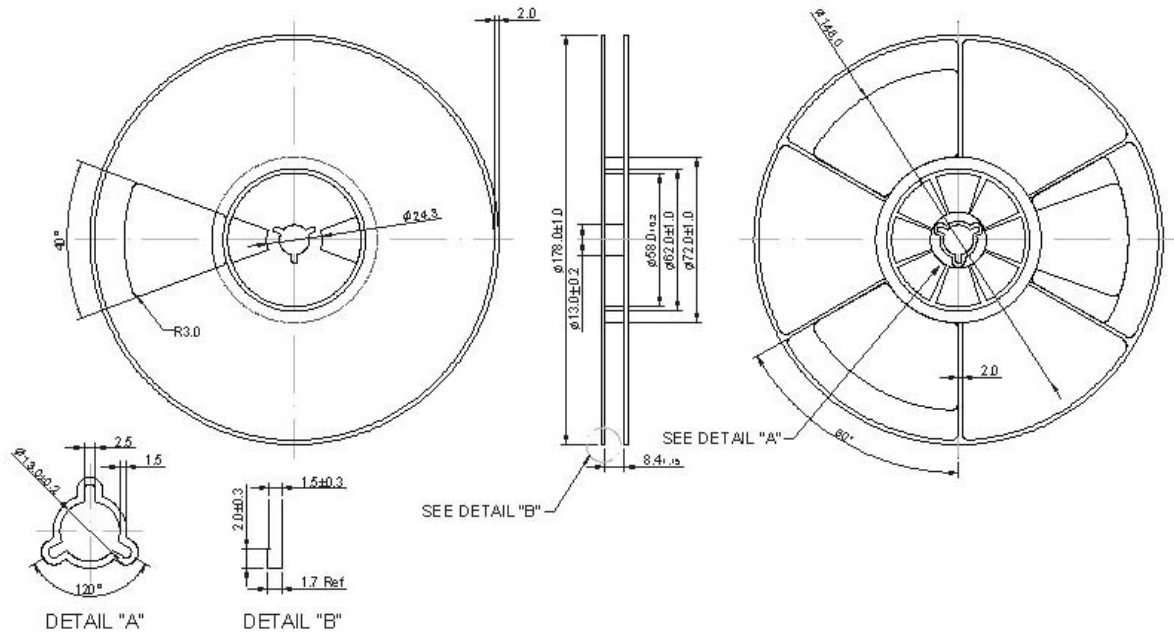

2. TAPE DIMENSION

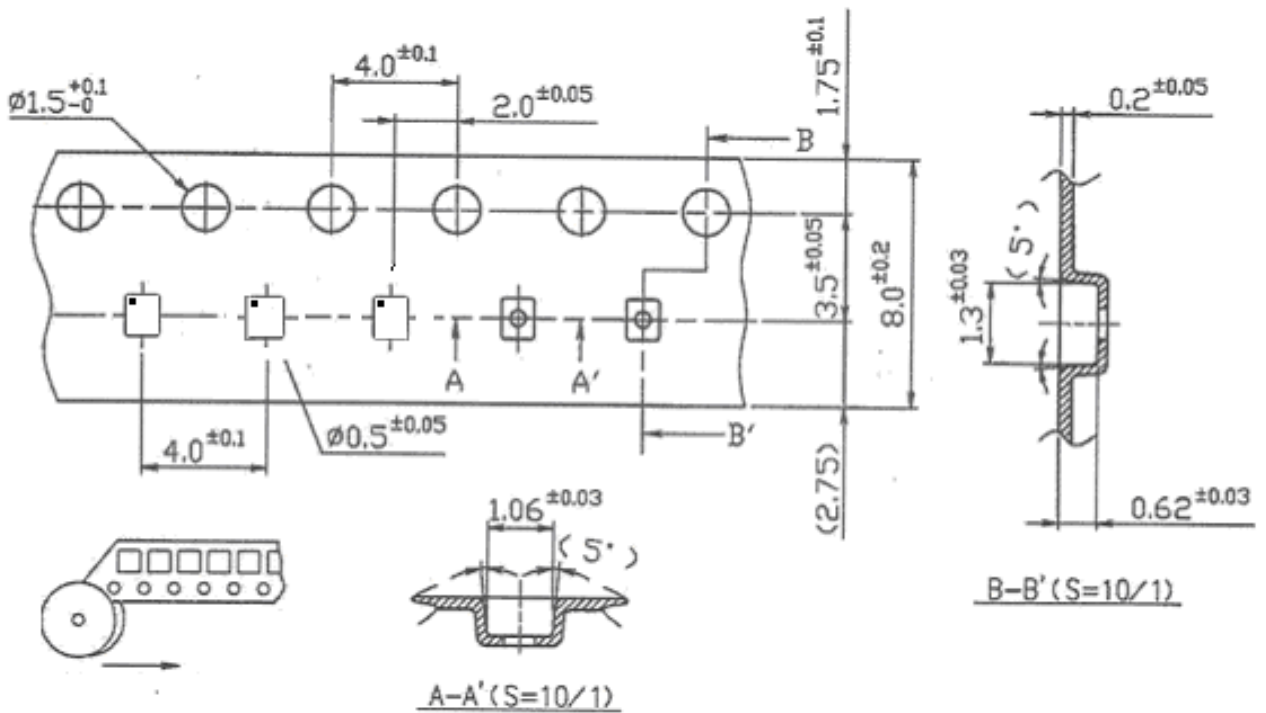

RECOMMENDED REFLOW PROFILE :

1. Preheating shall be fixed at 150~180°C for 60~90 seconds.
2. Ascending time to preheating temperature 150°C shall be 30 seconds min.
3. Heating shall be fixed at 220°C for 50~80 seconds and at 245~260°C peak (min. 10sec).
4. Time : 2 times.

