

SF2696QM

**1950/2140 MHz
SAW Duplexer**

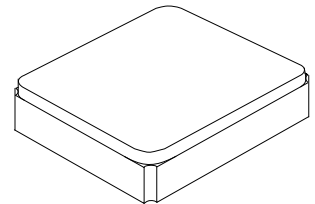

SM1612-4

Maximum Rating:

- Input Power Level: 30dBm.
- DC Voltage : 0 V
- Operating Temperature: -30°C to +85°C
- Storage Temperature: -40°C to +100°C
- Moisture Sensitivity Level: Level 1 (**MSL 1**)

Electrical Characteristics:

Tx to Ant

Item		Unit	Min	Typ	Max	Remarks
Center frequency		MHz		1950		
Insertion Loss	1920-1980 MHz	dB	-	1.6	2.0	
	1920.25-1979.75 MHz	dB	-	1.6	2.0	
Amplitude Ripple		dB	-	0.7	1.2	
VSWR	Tx		-	1.3	2.1	
	Ant		-	1.3	2.0	
Attenuation	1559-1563 MHz	dB	37	42	-	
	1565-1606 MHz	dB	37	42	-	
	1805-1865 MHz	dB	10	28	-	
	1865-1880 MHz	dB	10	28	-	
	2010-2025 MHz	dB	14	20	-	15~85°C
	2110-2170 MHz	dB	44	55	-	
	2400-2500 MHz	dB	33	37	-	
	3840-3960 MHz	dB	26	38	-	

Ant to Rx

Item		Unit	Min	Typ	Max	Remarks
Center frequency		MHz		2140		
Insertion Loss	2110-2170 MHz	dB	-	1.8	2.3	
	2110.25-2169.75 MHz	dB	-	1.8	2.3	
Amplitude Ripple		dB	-	0.7	1.2	
VSWR	Tx	2110-2170 MHz	-	1.7	2.1	
	Ant	2110-2170 MHz	-	1.8	2.3	
Attenuation	190 MHz MHz	dB	50	85	-	
	1730-1790 MHz	dB	40	54	-	
	1920-1980 MHz	dB	45	55	-	
	1980-2015 MHz	dB	19	54	-	
	2015-2075 MHz	dB	18	31	-	
	2400-2500 MHz	dB	35	43	-	
	4030-4160 MHz	dB	40	54	-	
	5960-6130 MHz	dB	33	52	-	

Item		Unit	Min	Typ	Max	Remarks
Tx to Rx	1920-1980 MHz	dB	54	57	-	
	2110-2170 MHz	dB	52	56	-	
Terminating Impedance	Tx port	Ω	50//8.2nH			
	Rx port	Ω	50			
	Ant port	Ω	50//3.0nH			
DC Impedance to ground		M Ω	100			

Schematic

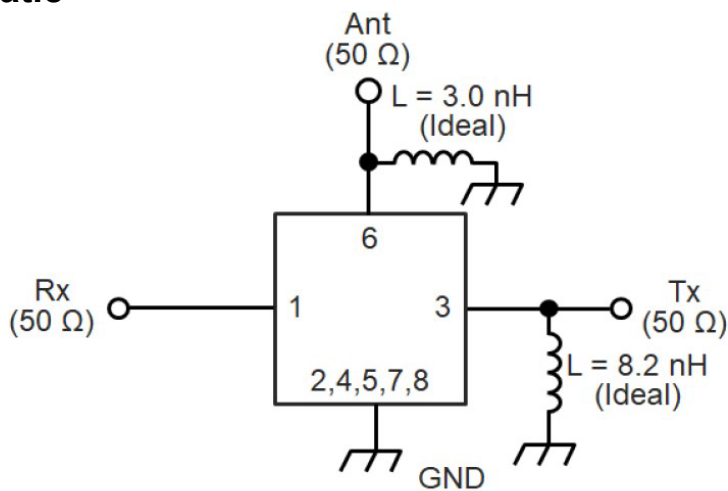

1 to 8 : Pin No.

Performance Plots

Tx to Ant

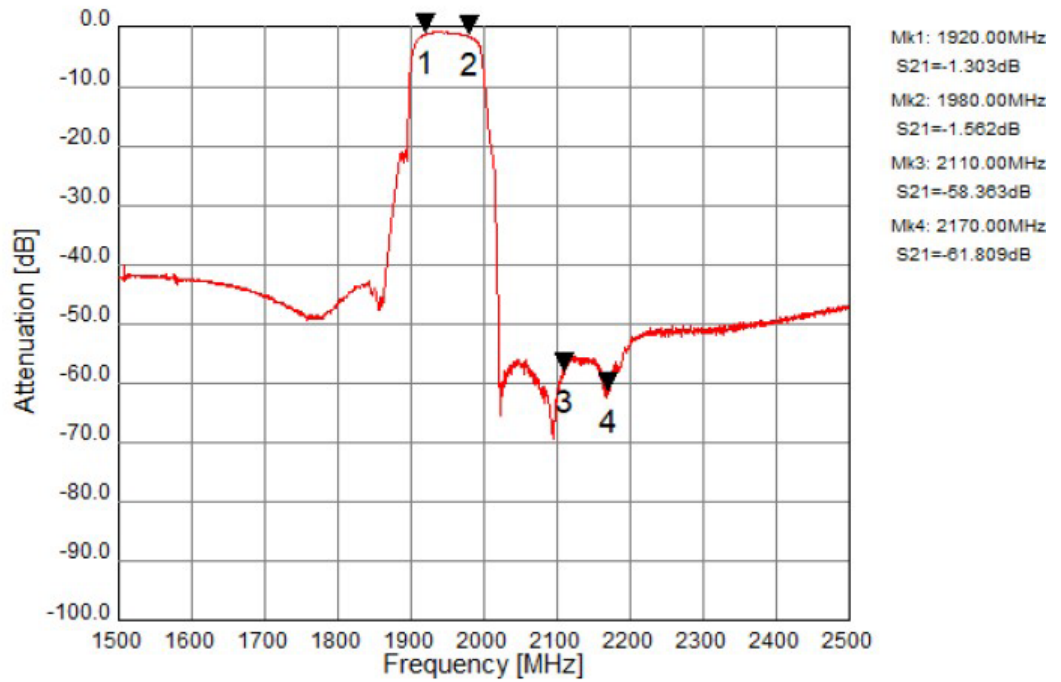

Ant to Rx

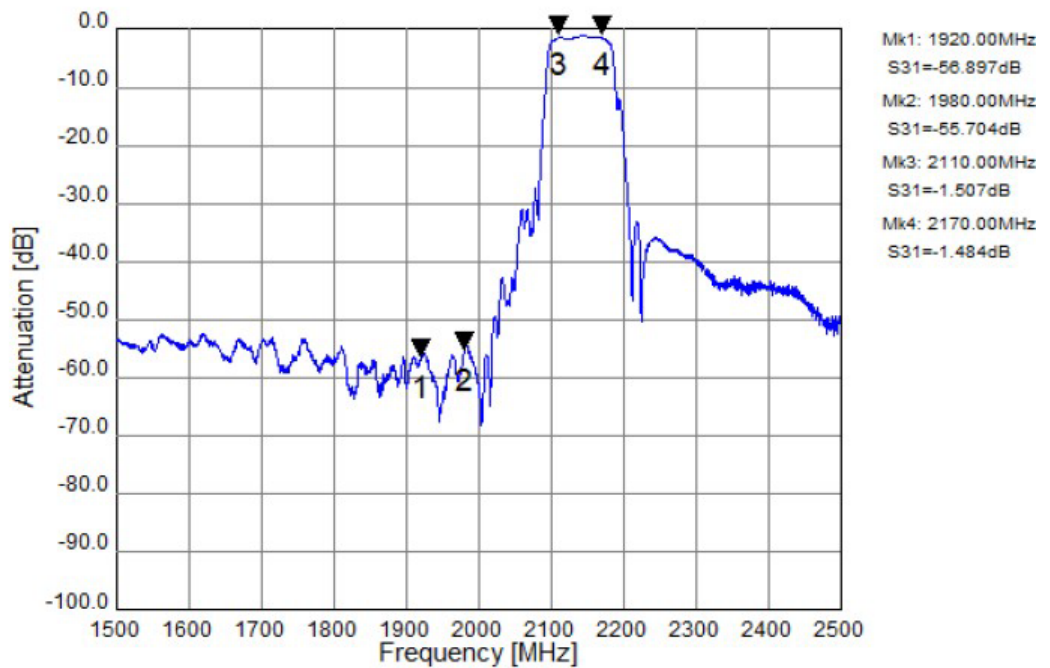

Tx to Ant, Ant to Rx

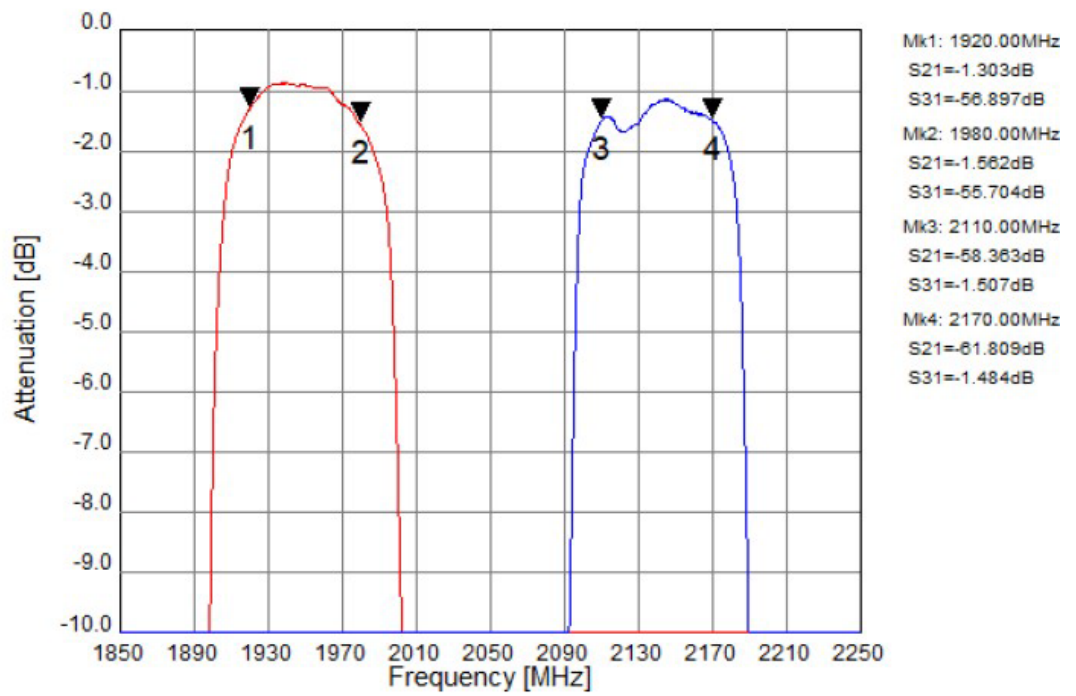

Tx to Rx Isolation

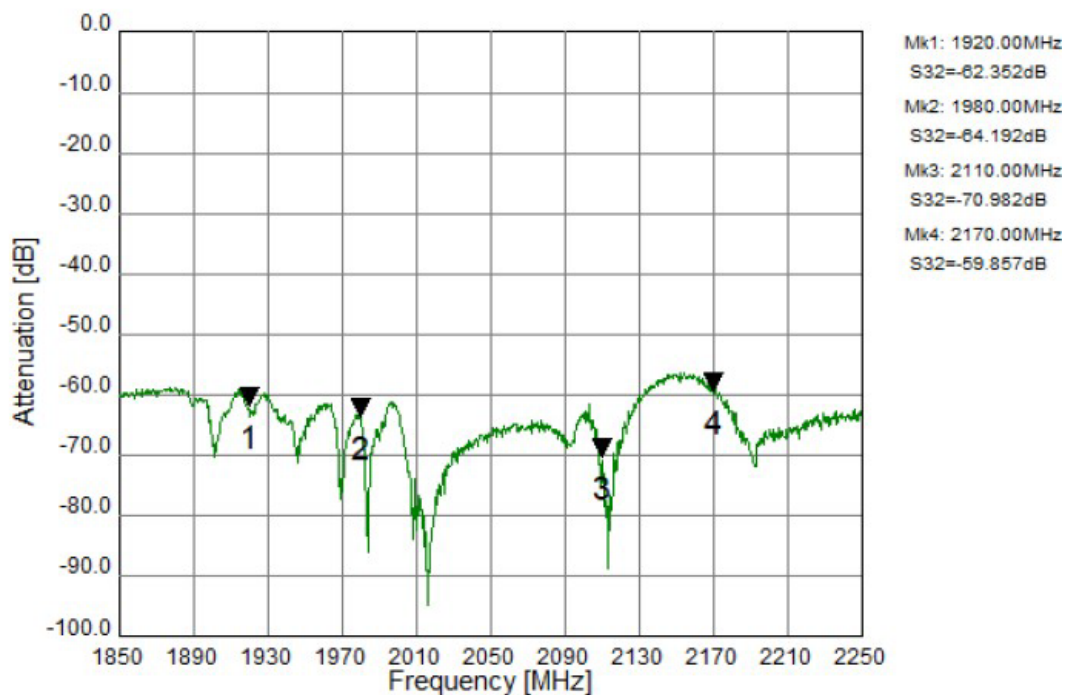

Tx Port

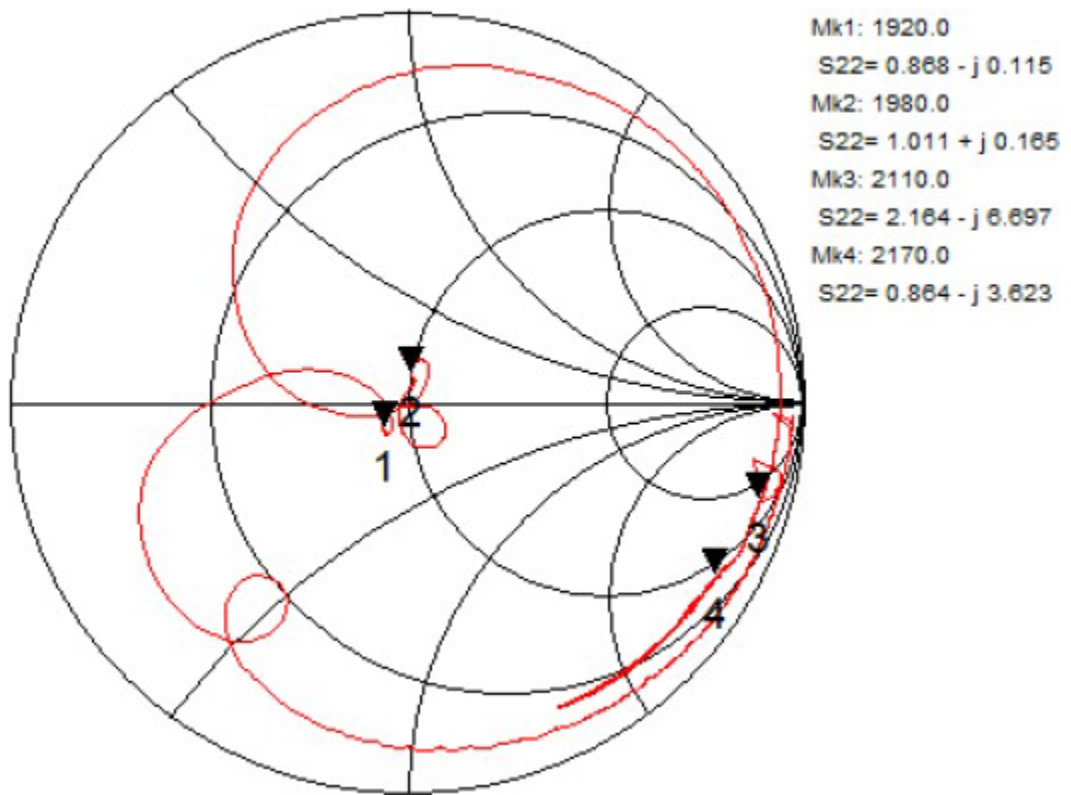
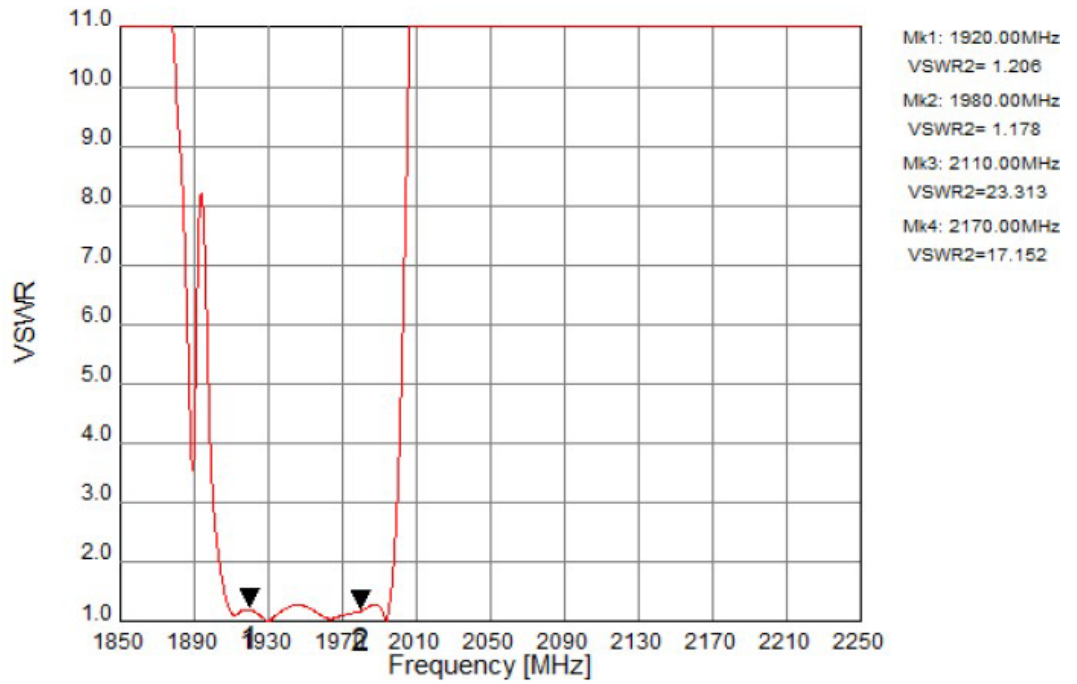

Rx Port

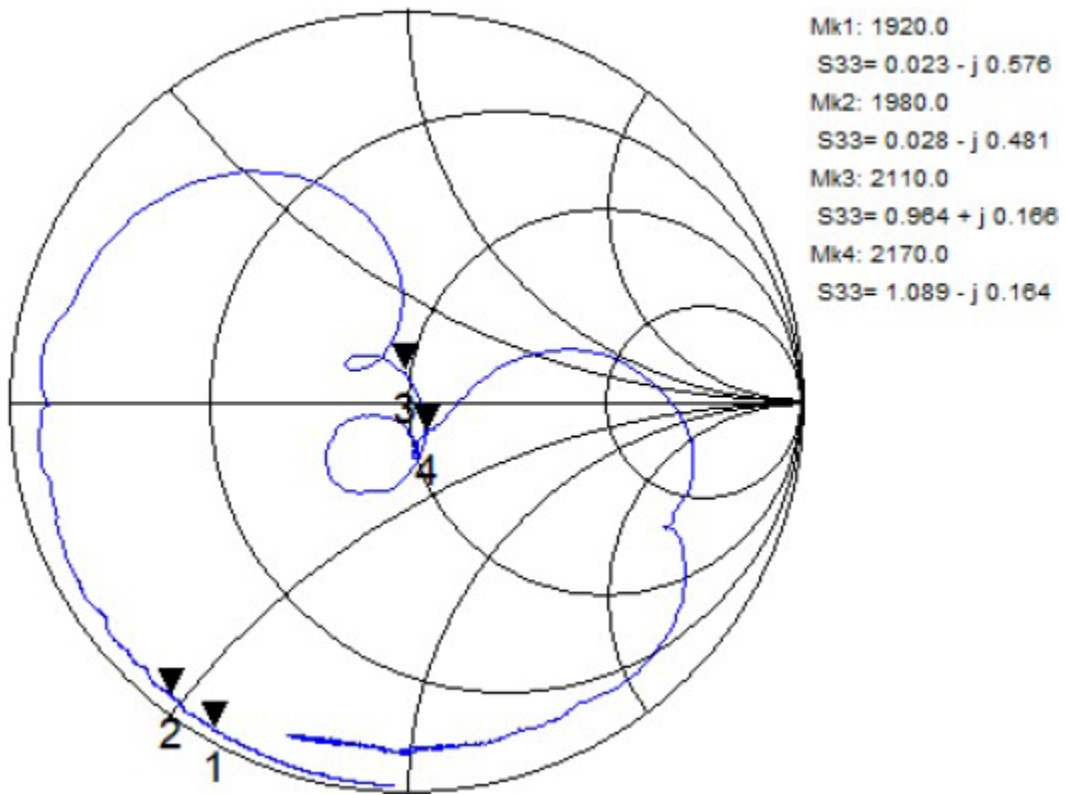
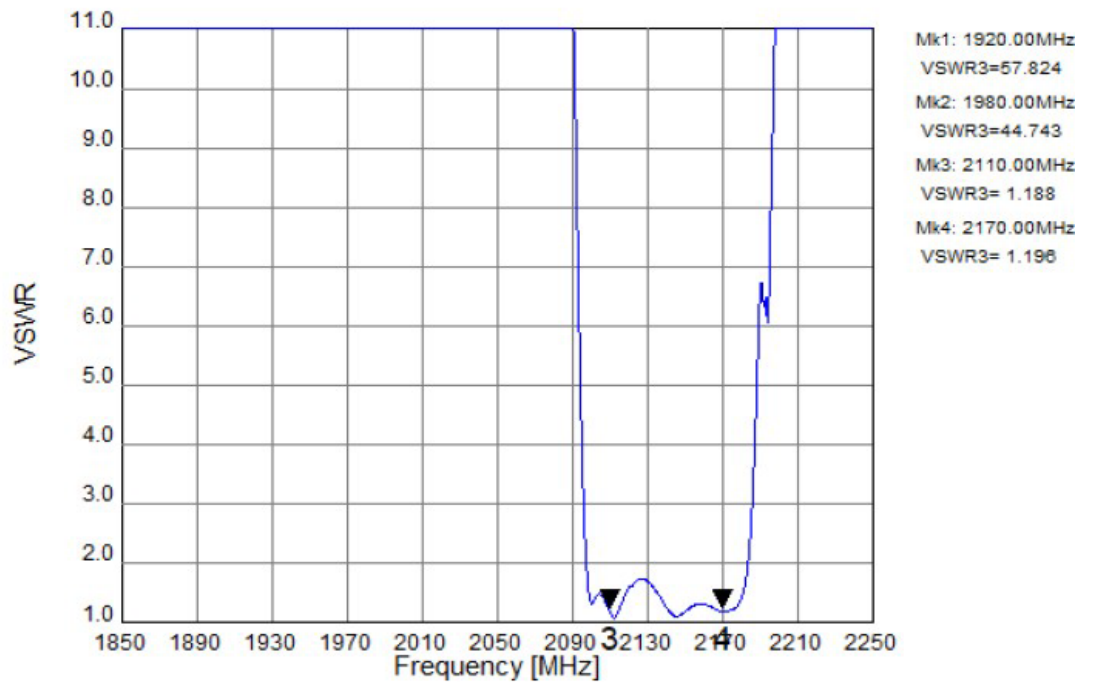

Ant Port

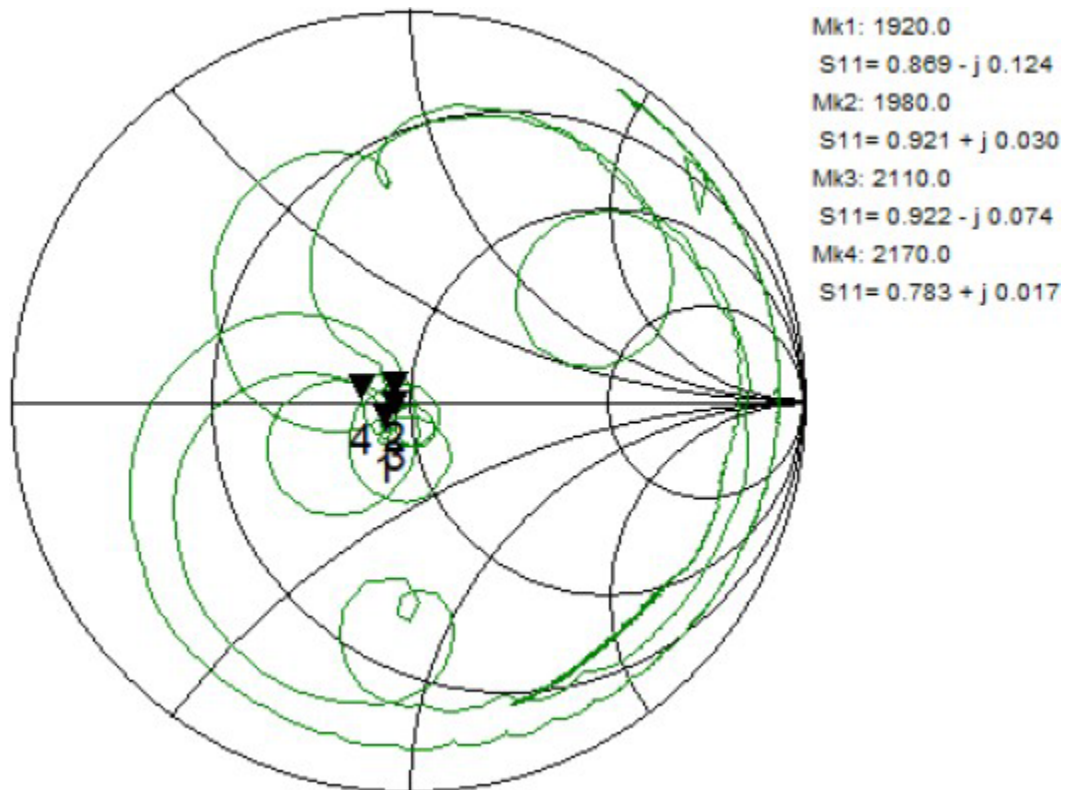
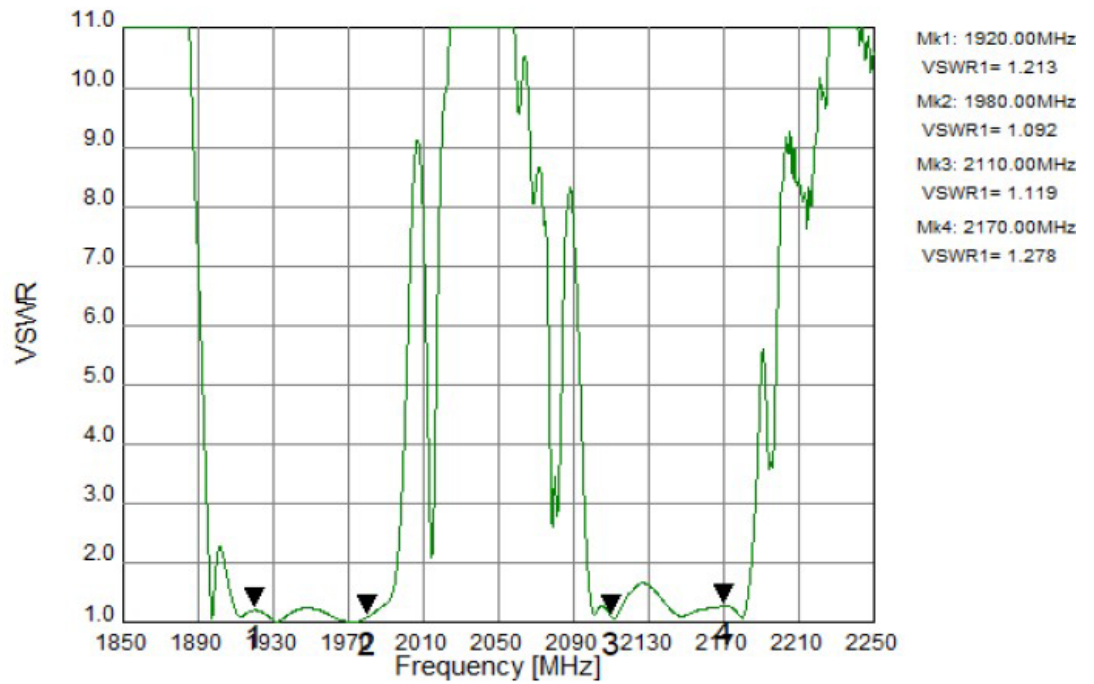

Tx to Ant (Wide Span)

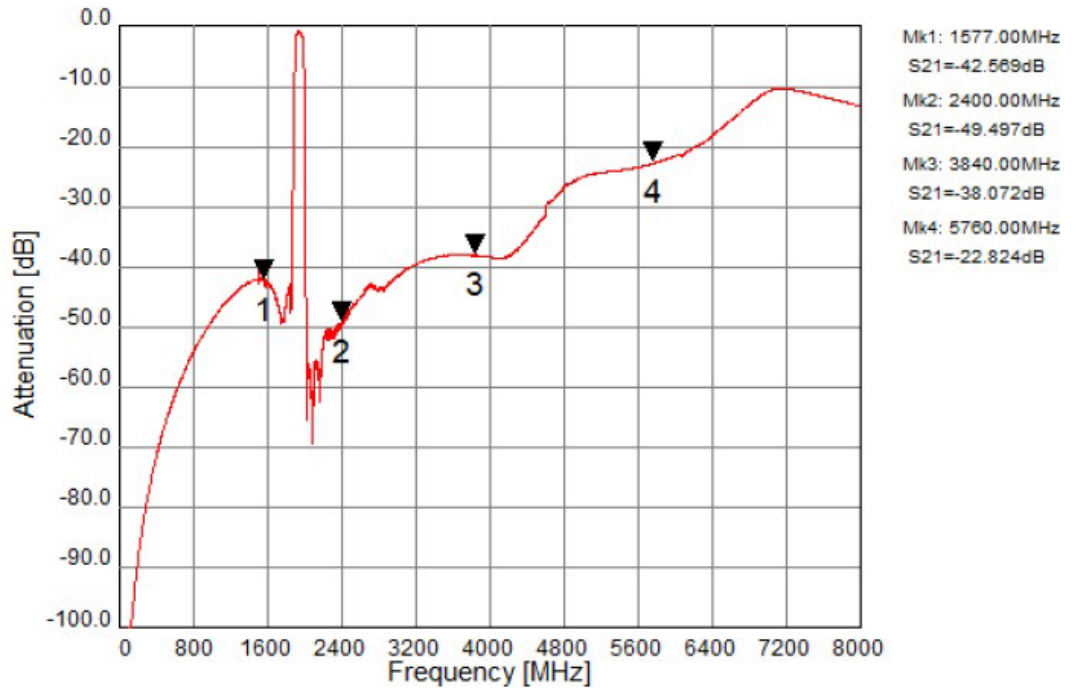

Ant to Rx (Wide Span)

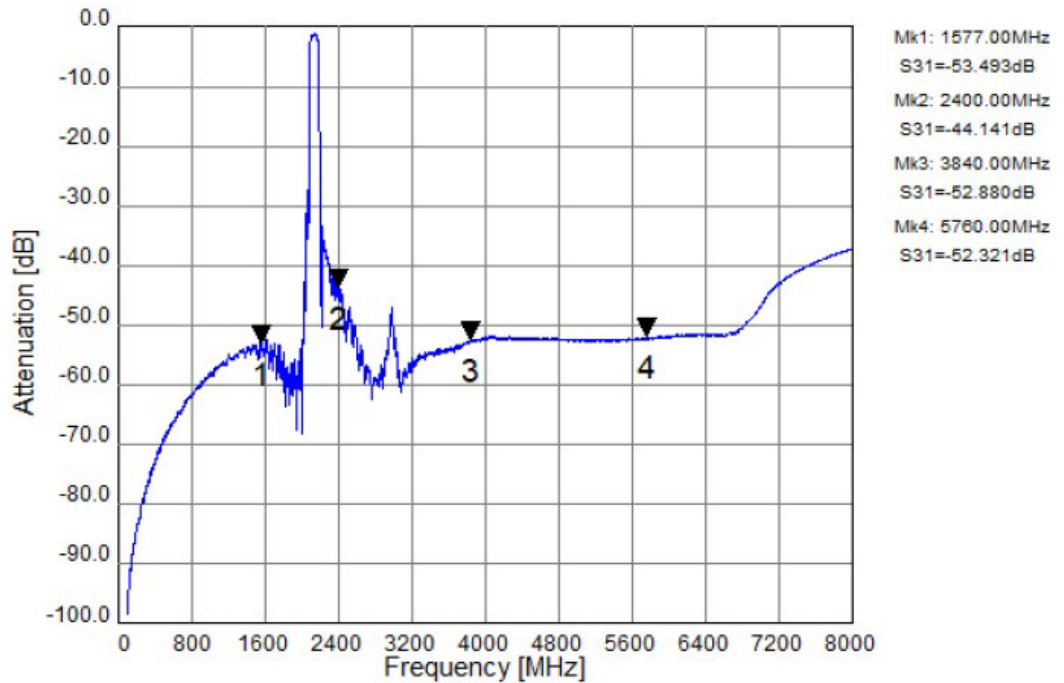

Package Drawing and Pin Description

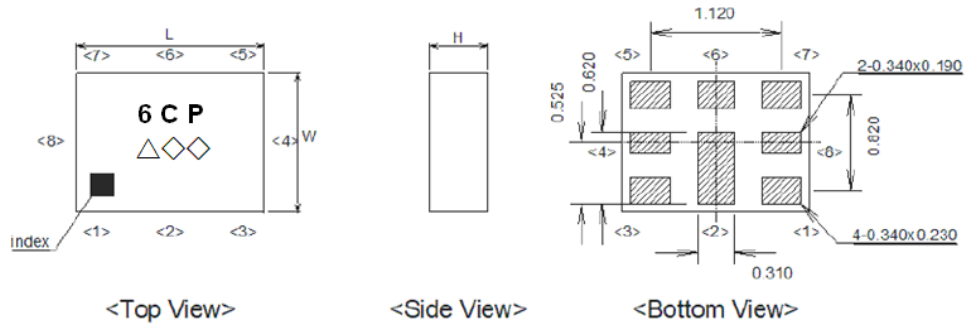

Unit : mm
1 to 8 : Pin No.

Marking name: 6CP(Part Symbol)

△: Trace Code.(2020 May → s,....., 2023 Dec → m)

◇◇: Lot Code.

Product Trace Code.Follow below table.(4-year cycle)

L = 1.6 +/- 0.1 mm

W = 1.2 +/- 0.1 mm

H = 0.44 mm Max

Year	Jan	Feb	Mar	Apr	May	Jun	Jul	Aug	Sep	Oct	Nov	Dec
2020	n	p	q	r	s	t	u	v	w	x	y	z
2021	A	B	C	D	E	F	G	H	J	K	L	M
2022	N	P	Q	R	S	T	U	V	W	X	Y	Z
2023	a	b	c	d	e	f	g	h	j	k	l	m

PCB Mounting Pattern

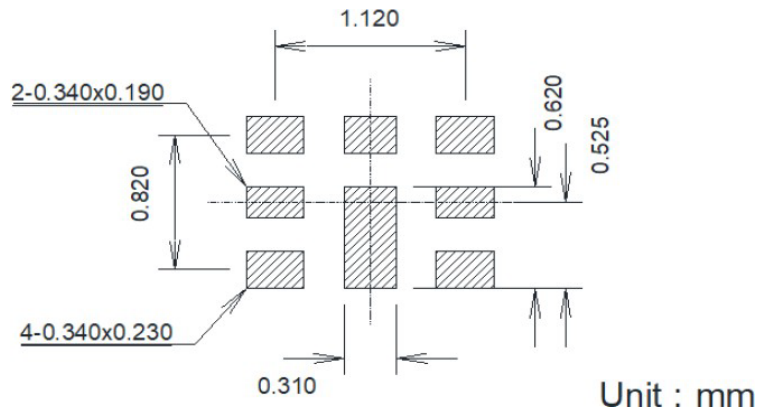

Unit : mm

Pin No.	Symbol	Function
1	Rx	Receiver
2	GND	Ground
3	Tx	Transmitter
4	GND	Ground
5	GND	Ground
6	Ant	Antenna
7	GND	Ground
8	GND	Ground

Notes:

- All units are in mm unless otherwise stated
- General Tolerance
 - Linear: X.XXX = ±0.050mm
 - X.XX = ±0.10mm
- Terminations
 - Au: 0.10 um min.
 - Pd: 0.10 um min.
 - Ni: 2-5 um
- Pin 1 indicated by 0.100 mm Chamfer

Reel Dimension

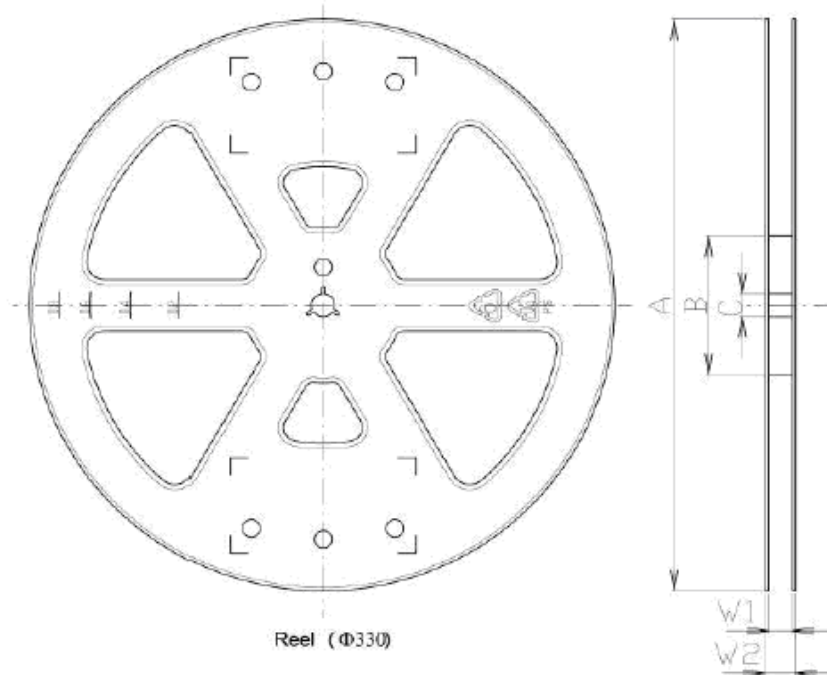

Order	Code	Quantity (pcs./reel)	A	B	C	W1	W2	Tape Pitch
Standard	Y	15,000	φ330	φ100	φ13 ±0.2	9.4 ±1.0	13.4 ±1.0	4.0 ±0.1
Option	Z	3,000	φ180	φ60	φ13 ±0.2	9 +1.0/-0.0	11.4 ±1.0	4.0 ±0.1

Unit:mm

Dimensions of Tape (Standard)

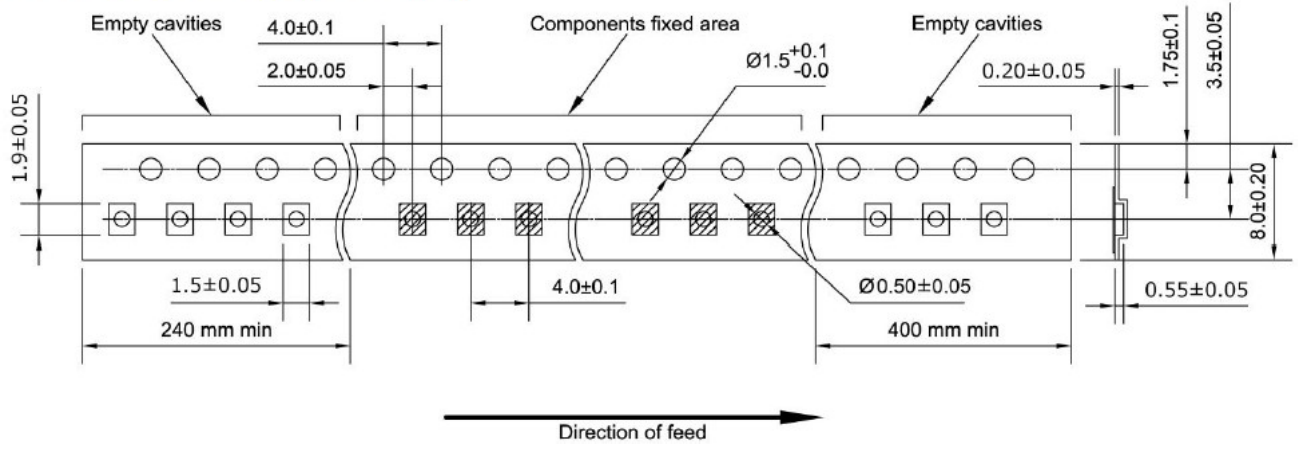

Recommended Solder Profile

1. Preheating shall be fixed at 150~180°C for 60~90 seconds.
2. Ascending time to preheating temperature 150°C shall be 30 seconds min.
3. Heating shall be fixed at 220°C for 50~80 seconds and at 260°C+0/-5°C peak (20~40sec).
4. Time: 2 times.

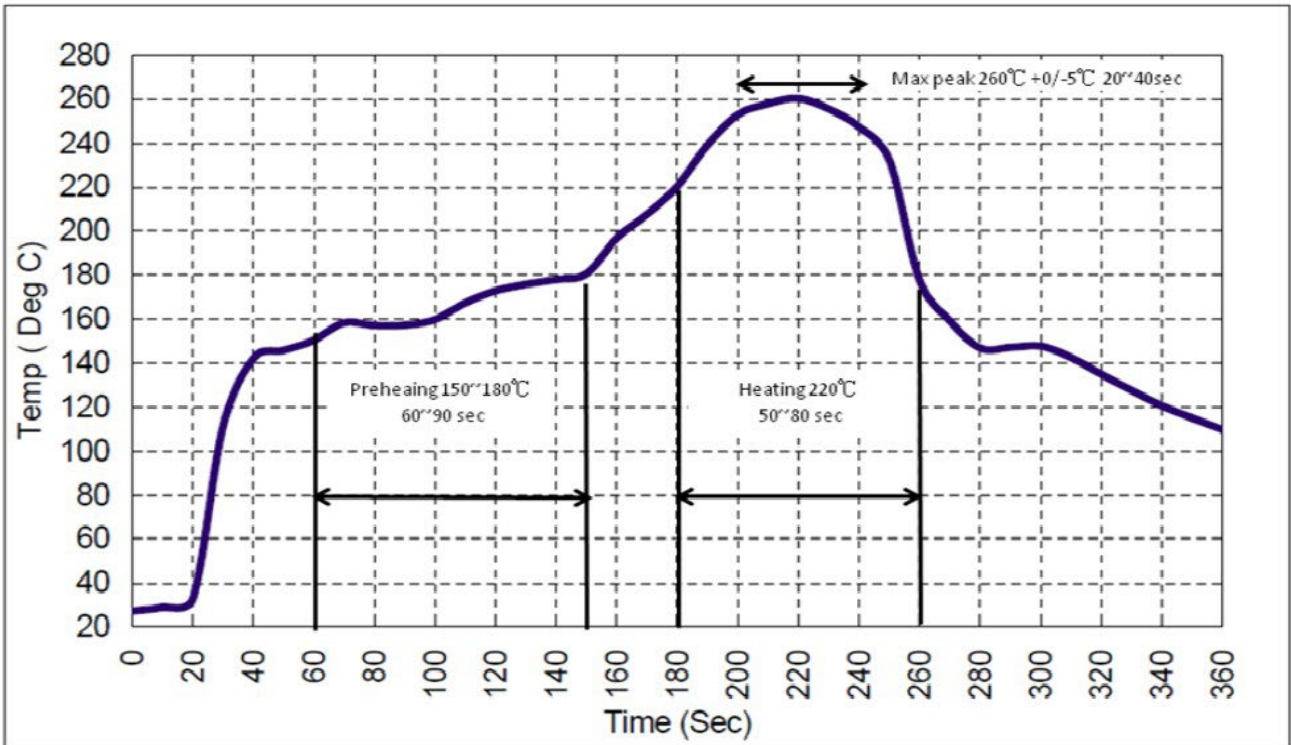

CAUTION: Electrostatic Sensitive Device. Observe precautions for handling.

NOTES:

1. The design, manufacturing process, and specifications of this device are subject to change.
2. US or International patents may apply.
3. This component was always RoHS compliant from the first date of manufacture.