

SF2716E

**1601 MHz
SAW Filter**

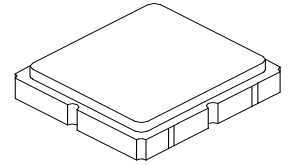

SM3030-6

MAXIMUM RATING:

- Input Power Level: 10 dBm
- DC Voltage : 3V
- Operating Temperature: -55°C to +85°C
- Storage Temperature: -55°C to +85°C
- Moisture Sensitivity Level: Level 1

ELECTRICAL CHARACTERISTICS:

Terminating source impedance (single ended) : $Z_s = 50 \Omega$

Terminating load impedance (single ended) : $Z_L = 50 \Omega$

Item	Unit	Min.	Typ.	Max.	Note
Center Frequency Fc	MHz	-	1601	-	-
Min. Insertion Loss IL	dB	-	3.4	5	-
Amplitude Ripple (1593 ~ 1609 MHz)	dB	-	1.1	1.5	-
Group Delay Ripple (1593 ~ 1609 MHz)	ns	-	9	15	-
VSWR (1593 ~ 1609 MHz)		-	1.9	2.2	-
Relative Attenuation (relative to 0 dB)					
D.C. ~ 1560 MHz	dB	35	50	-	-
1563 ~ 580 MHz	dB	11	16.5	-	-
1622 ~ 650 MHz	dB	11	20.5	-	-
1650 ~ 000 MHz	dB	35	43.5	-	-
Temperature Coefficient of Frequency	ppm/°C	-	-36	-	-

Deviation of Center and Bounder Frequencies in temperature range from -55 °C to +85 °C by TCD = -35 ppm/grad.

MEASUREMENT CIRCUIT:

HP Network analyzer

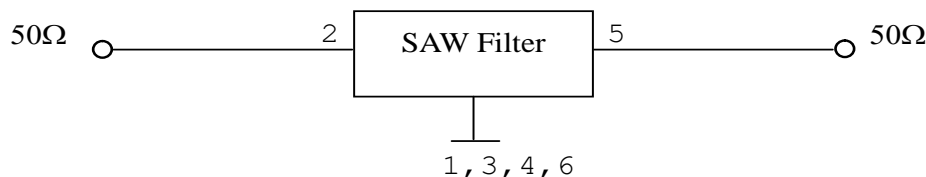



CAUTION: Electrostatic Sensitive Device. Observe precautions for handling.

NOTES:

1. The design, manufacturing process, and specifications of this device are subject to change.
2. US or International patents may apply.
3. RoHS compliant from the first date of manufacture.

OUTLINE DRAWING:

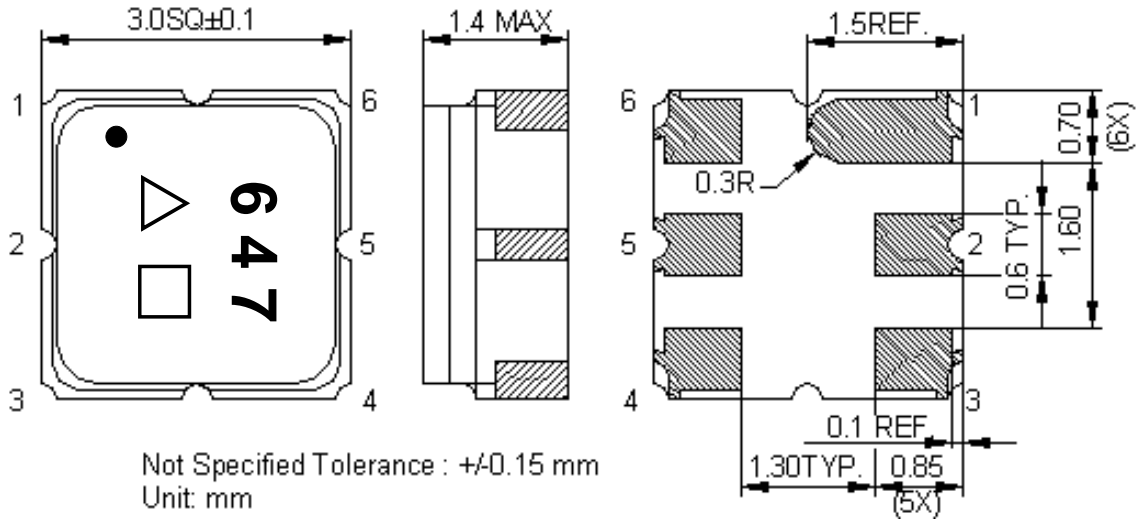

2 : Input

5 : Output

1,3,4,6 : Ground

Δ : Year Code (2019->9, 2020->0, ..., 2028->8)

\square : Date Code (W01->A, W02->B, ..., W27->a, ..., W52->z)

Date Code Table

WK01	WK02	WK03	WK04	WK05	WK06	WK07	WK08	WK09	WK10	WK11	WK12	WK13
A	B	C	D	E	F	G	H	I	J	K	L	M
WK14	WK15	WK16	WK17	WK18	WK19	WK20	WK21	WK22	WK23	WK24	WK25	WK26
N	O	P	Q	R	S	T	U	V	W	X	Y	Z
WK27	WK28	WK29	WK30	WK31	WK32	WK33	WK34	WK35	WK36	WK37	WK38	WK39
a	b	c	d	e	f	g	h	i	j	k	l	m
WK40	WK41	WK42	WK43	WK44	WK45	WK46	WK47	WK48	WK49	WK50	WK51	WK52
n	o	p	q	r	s	t	u	v	w	x	y	z

PCB FOOTPRINT:

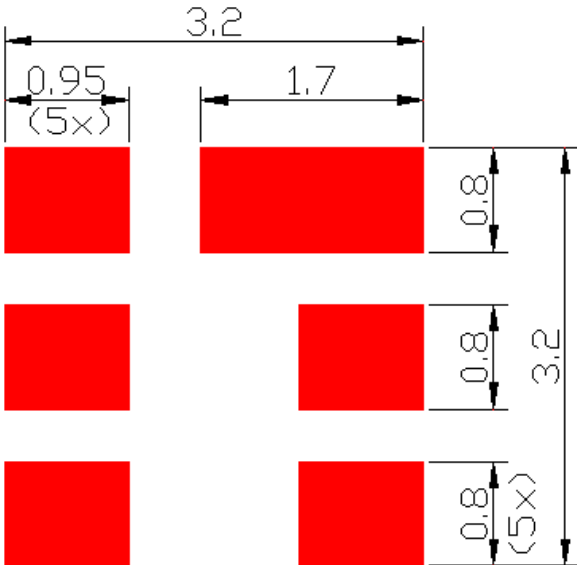

FREQUENCY CHARACTERISTICS: Transfer function

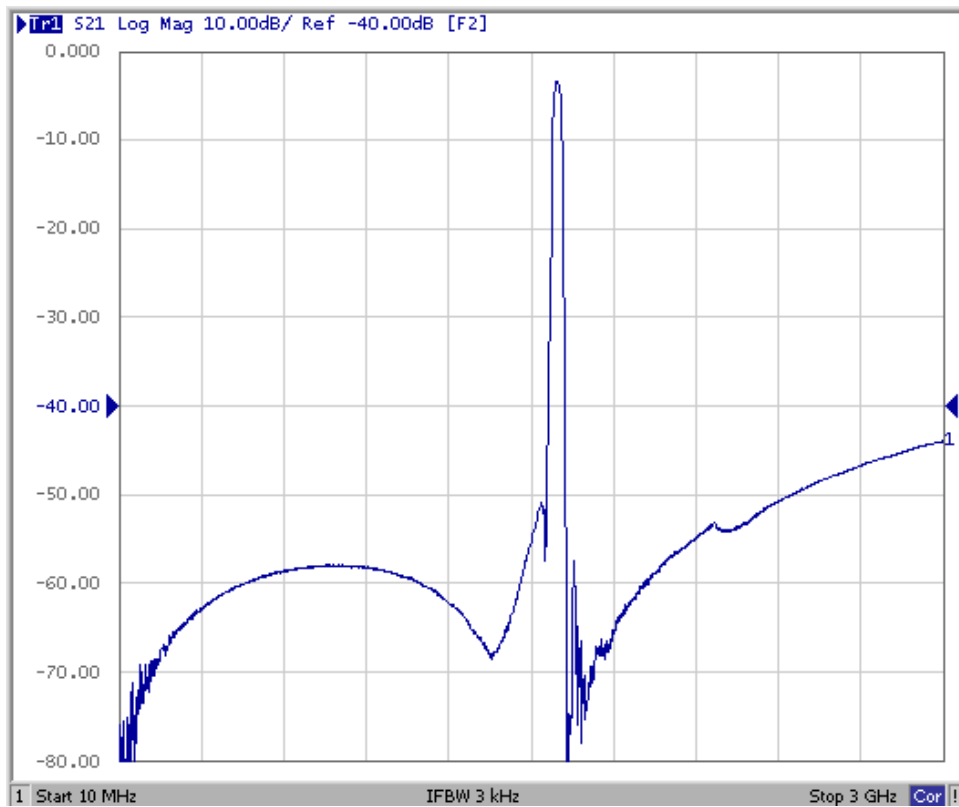
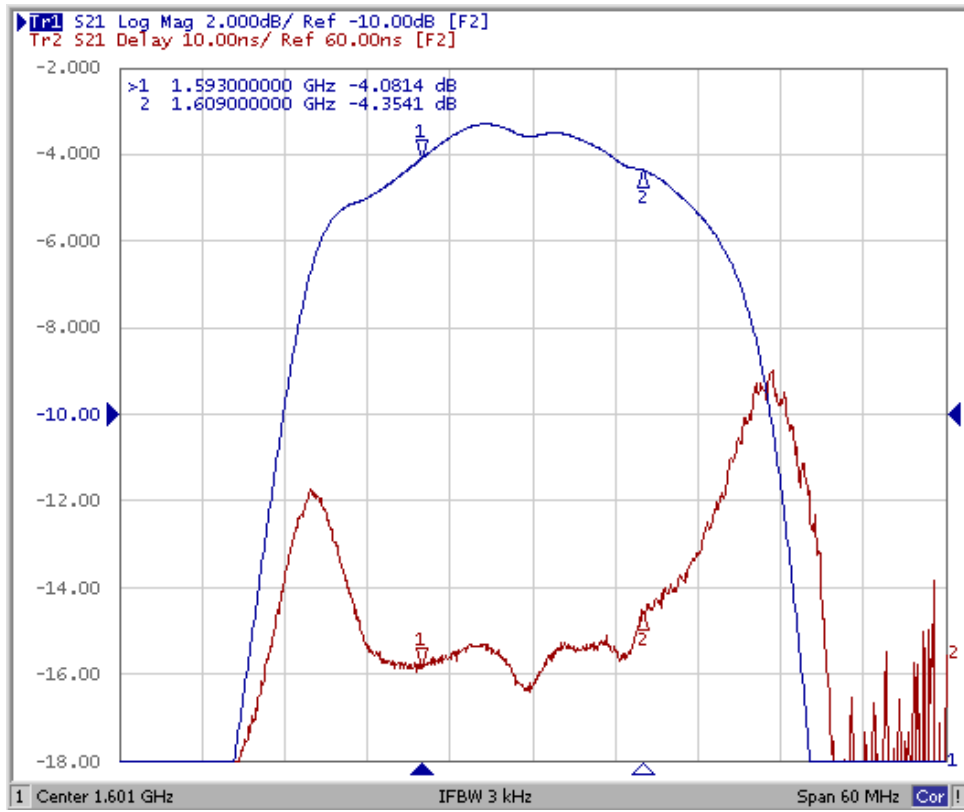

Reflections Functions :

S11 VSWR

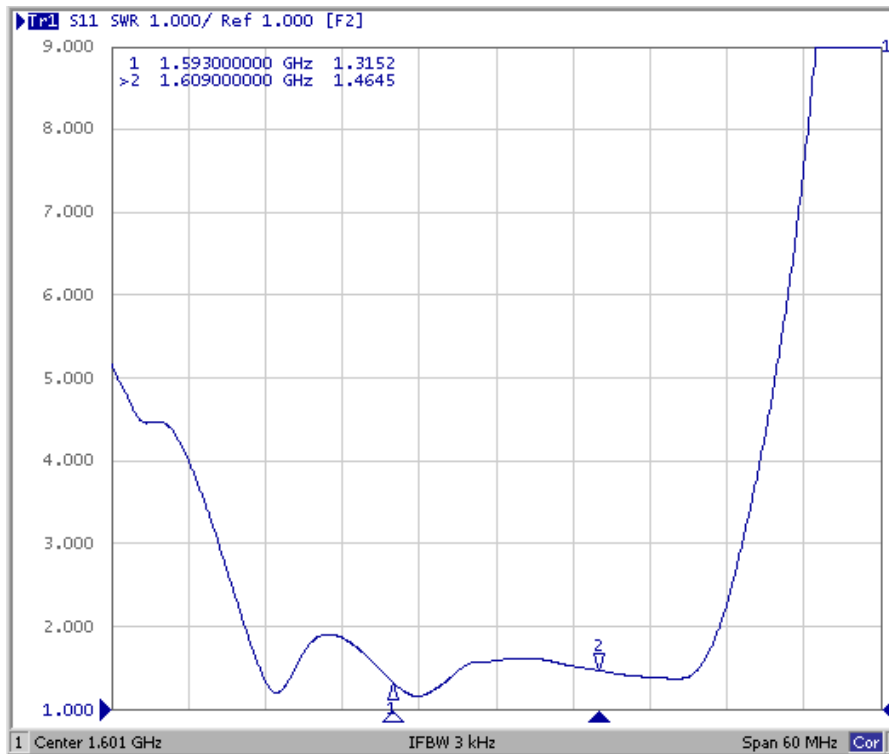

S22 VSWR

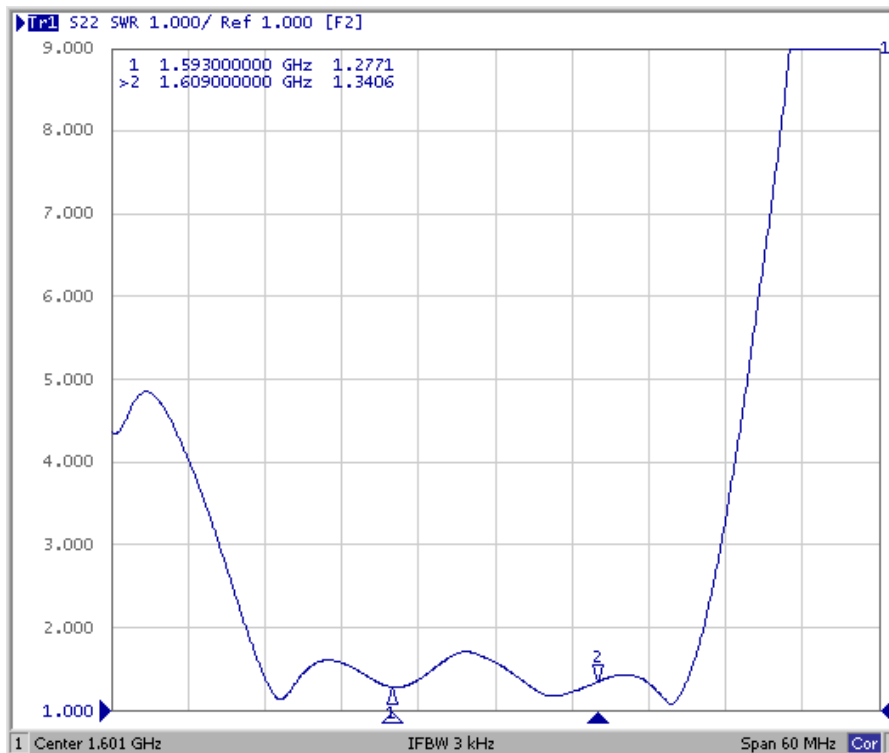

PACKING:

1. REEL DIMENSION

Reel Count: 7" = 1000

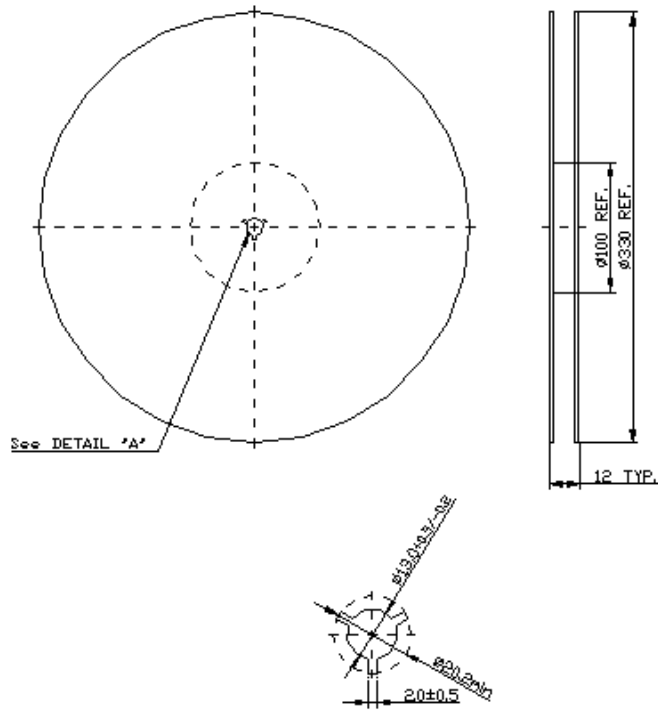

2. TAPE DIMENSION

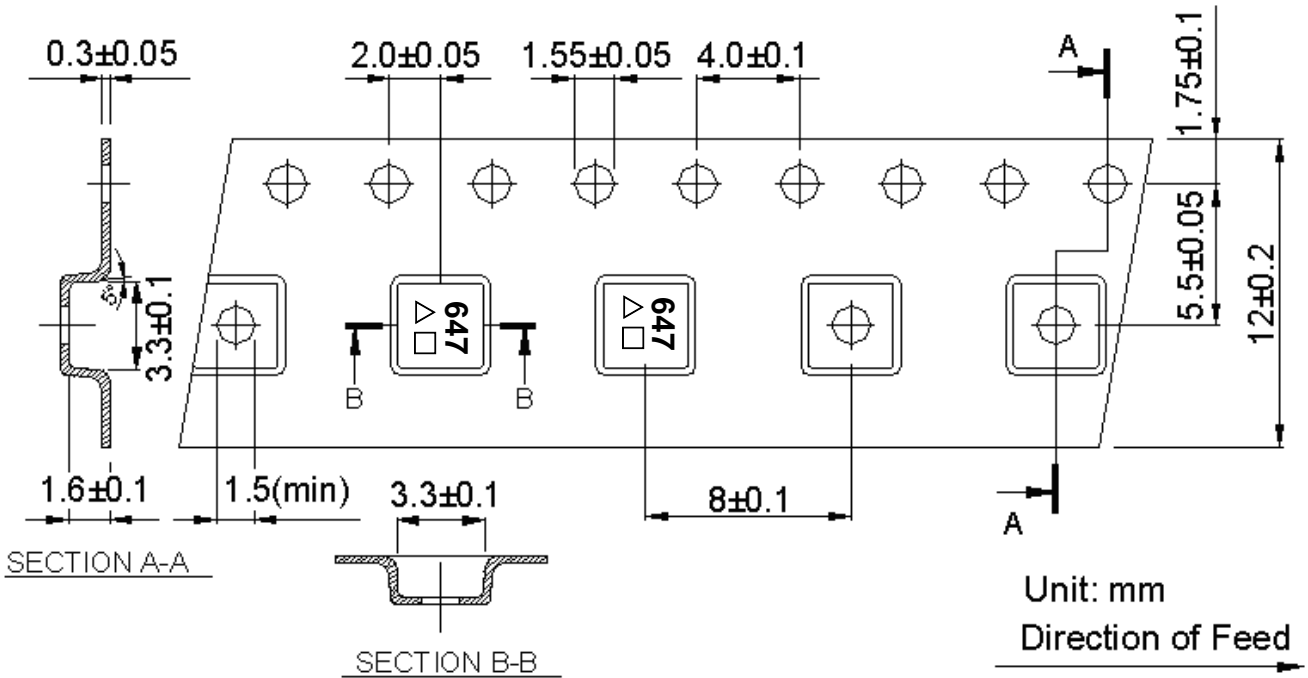

RECOMMENDED REFLOW PROFILE :

- 1. Preheating shall be fixed at 150~180°C for 60~90 seconds.
- 2. Ascending time to preheating temperature 150°C shall be 30 seconds min.
- 3. Heating shall be fixed at 220°C for 50~80 seconds and at 245~260°C peak (min. 10sec).
- 4. Time : 2 times.

