

XO6016

25.000000 MHz
XO

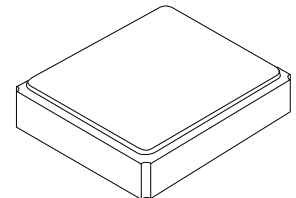

SM3225-4

Features:

- Surface Mount Seam Weld Package
- Excellent Reliability Performance
- Good Frequency Perturbation and Stability over temperature
- Moisture Sensitivity Level (MSL) : Level-1

Application:

- 1.2 V Supply Voltage CMOS Output
- Option-able stand-by function for output .

Electrical Specifications:

➤ FREQUENCY

	Parameter	Min.	Typ.	Max.	Units	Test Condition
1-1	Nominal Frequency	25.000000			MHz	
1-2	Frequency stability (Overall)	-30		+30	ppm	Frequency stability includes frequency tolerance@25°C and frequency stability vs. operating temperature range and voltage variance and first year aging.
1-3	Aging	-3		+3	ppm	Frequency drift in first year
1-4	Operating Temperature range	-40		+85	°C	The operating temperature range over which the frequency stability is measured.
1-5	Storage Temperature range	-55		+125	°C	

➤ POWER SUPPLY

	Parameter	Min.	Typ.	Max.	Units	Test Condition
2-1	Supply voltage	1.08	1.2	1.32	V	
2-2	Current			6	mA	At maximum supply voltage

➤ **OUTPUT**

	Parameter	Min.	Typ.	Max.	Units	Test Condition
3-1	Output waveform	CMOS				
3-2	Duty Cycle	45	50	55	%	
3-3	Start Time			3	mSec	
3-4	Transition Time : Rise/Fall Time			6	nSec	
3-5	Output Level	Output High (Logic "1")	1.08		V	
3-6		Output Low (Logic "0")		0.12	V	
3-7	Output Load			15	pF	
3-8	Tri-State	Output Active	0.84 or Floating		V	Pin 1 Tri-State
3-9		Output in High-Impedance state			0.36	V

Mechanical Dimensions (mm):

Base 1

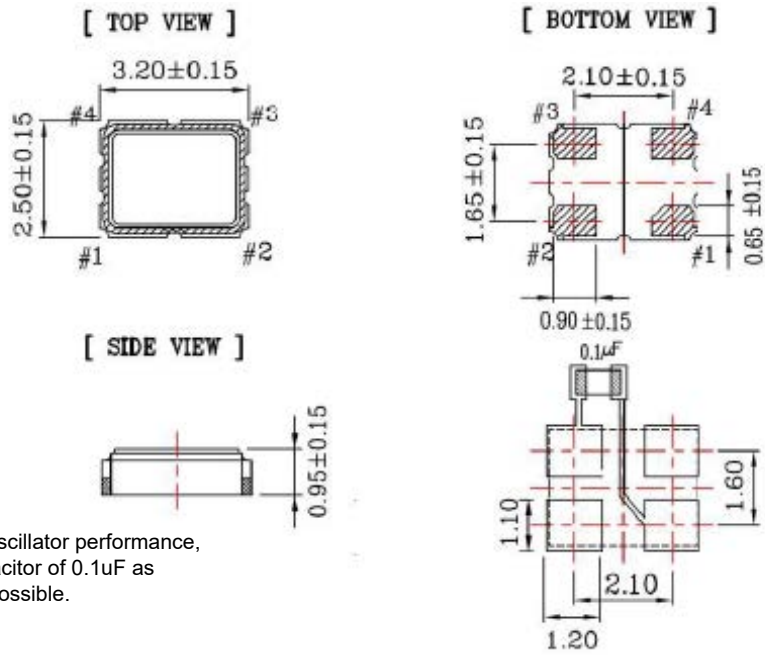

*To ensure optimal oscillator performance, place a by-pass capacitor of 0.1µF as close to the part as possible. VDD and GND pads.

Base 2

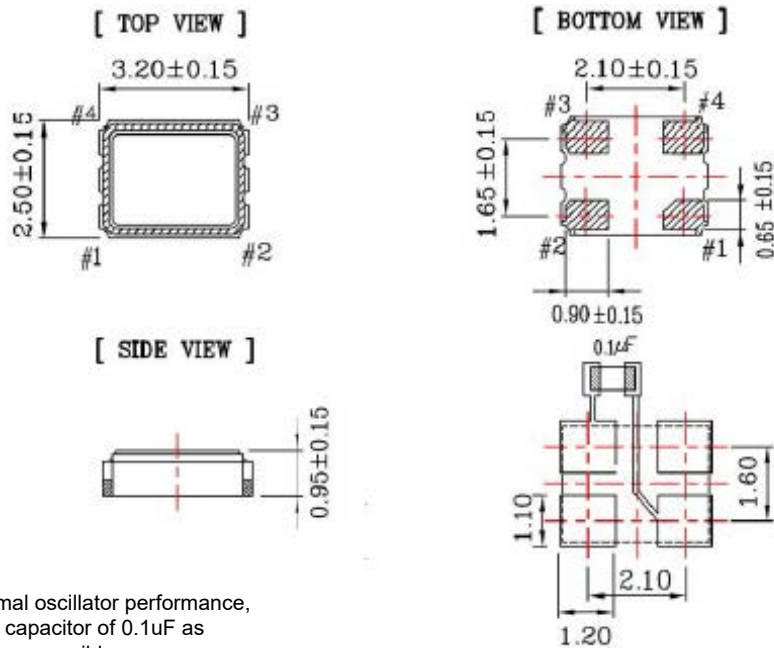

*To ensure optimal oscillator performance, place a by-pass capacitor of 0.1µF as close to the part as possible. VDD and GND pads.

PIN FUNCTIONS

Pin	Function
#1	Tri-State
#2	GND
#3	Output
#4	V _{DD}

Test Circuit:

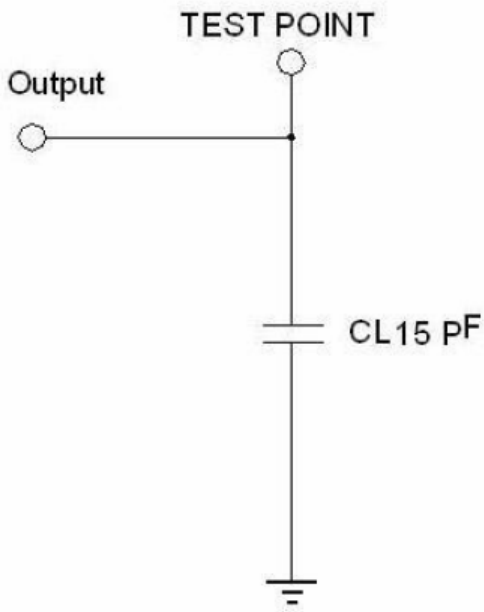

Output Waveform :

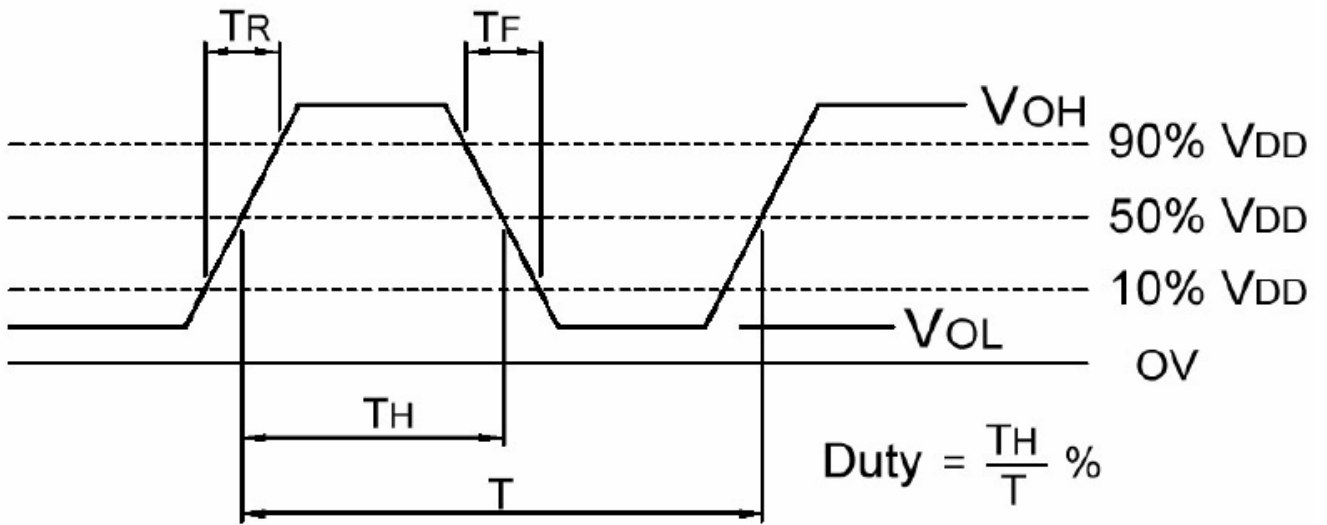

Marking:

Line 1 : Frequency (25.00)

Line 2 : ⊕WDXX (Product Code + Date Code + Internal Traceability Code (XX) : Can be 1 or 2 letters)

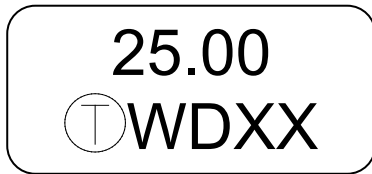

Product Code Table

Year	2017	2018	2019	20120
	2021	2022	2023	2024
	2025	2026	2023	2024
Product code	W	w	<u>W</u>	<u>w</u>

Date Code Table

WK01	WK02	WK03	WK04	WK05	WK06	WK07	WK08	WK09	WK10	WK11	WK12	WK13
A	B	C	D	E	F	G	H	I	J	K	L	M
WK14	WK15	WK16	WK17	WK18	WK19	WK20	WK21	WK22	WK23	WK24	WK25	WK26
N	O	P	Q	R	S	T	U	V	W	X	Y	Z
WK27	WK28	WK29	WK30	WK31	WK32	WK33	WK34	WK35	WK36	WK37	WK38	WK39
a	b	c	d	e	f	g	h	i	j	k	l	m
WK40	WK41	WK42	WK43	WK44	WK45	WK46	WK47	WK48	WK49	WK50	WK51	WK52
n	o	p	q	r	s	t	u	v	w	x	y	z

Reel Dimensions (mm):

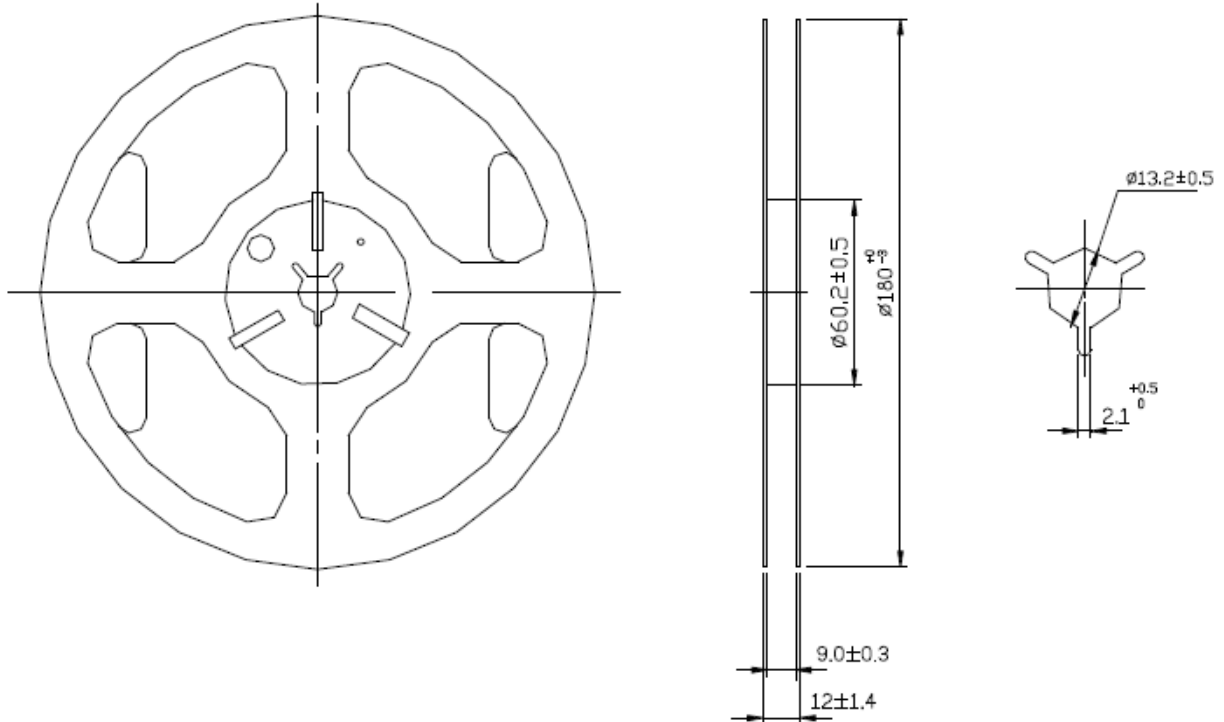

Tape Dimensions (mm):

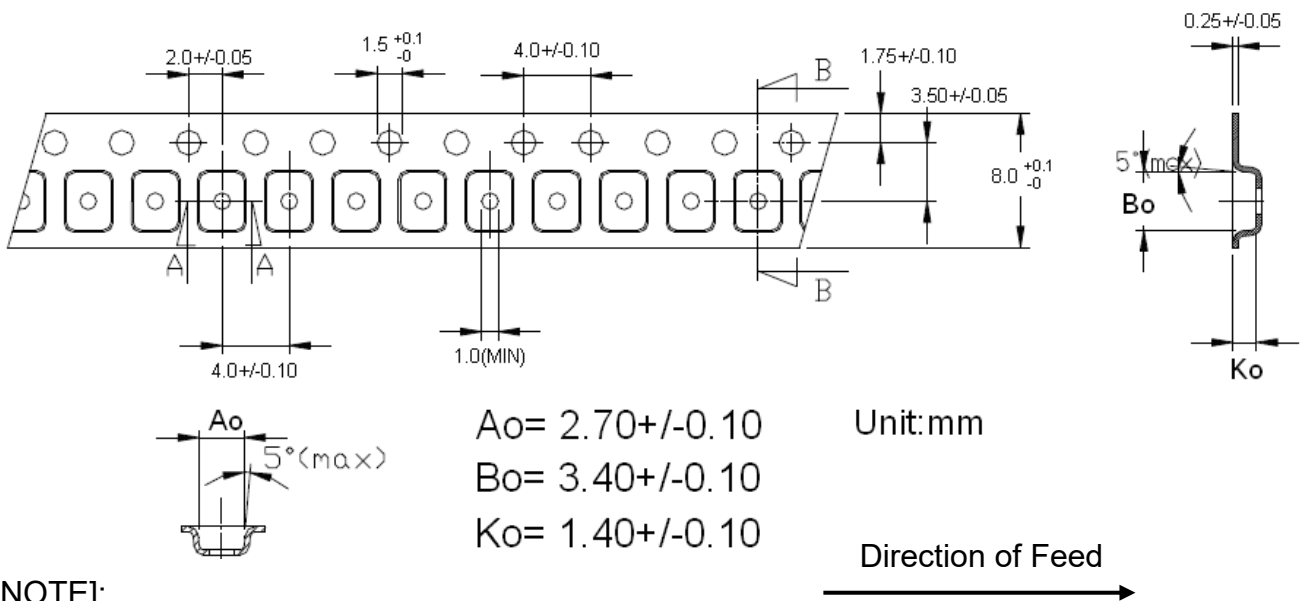

[NOTE]:

1. Unless otherwise specified tolerance on dimension ± 0.1 mm.
2. Material: conductive polystyrene with color black.
3. 10 pitch cumulative tolerance ± 0.2 mm.

Packing direction

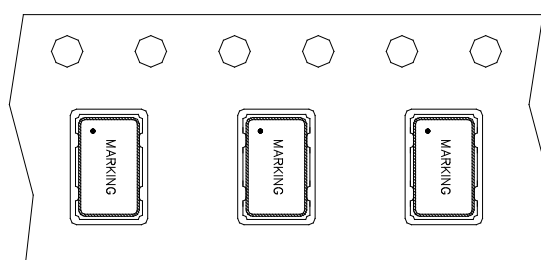

Packing Quantity/Packing:

1K pcs maximum per reel

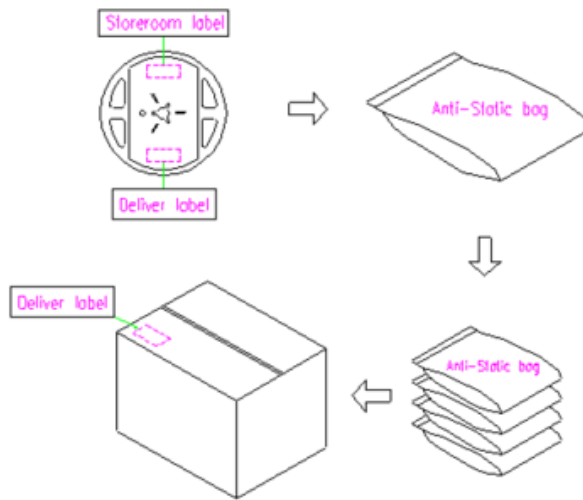

Reflow Profile:

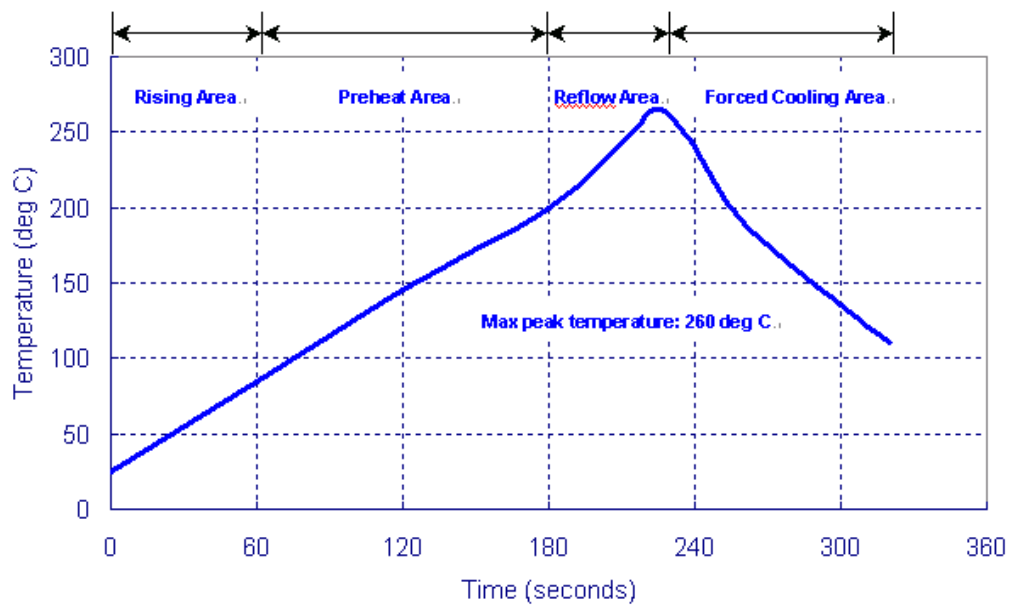

- Note: 1. Max peak temperature: 260+/-5 deg C; Time: 10+/-2 sec
- 2. Temperature: 217+/-5 deg C; Time: 90~100 sec

Reliability Specifications

Test name	Test process / method	Reference standard
Mechanical characteristics		
resistance to Soldering heat (IR reflow)	Temp./ Duration : 265°C /10sec ×2 times Total time : 4min.(IR-reflow)	EIAJED-4701 -300(301)M(II)
Vibration	Total peak amplitude : 1.5mm Vibration frequency : 10 to 2000 Hz Sweep period : 20 minute Vibration directions : 3 mutually perpendicular Duration : 2 hr / direc.	MIL-STD 202G method 204
Mechanical Shock	directions : 3 impacts per axis Acceleration : 3000g's, +20/-0 % Duration : 0.3 ms (total 18 shocks) Waveform : Half-sine	MIL-STD 202G method 213
Solderability	Solder Temperature:265±5°C Duration time: 5±0.5 seconds.	J-STD-002
Environmental characteristics		
Thermal Shock	Heat cycle conditions -40 °C (30min) ↔ 85 °C (30min) * cycle time : 10 times	MIL-STD 883G method 1010.8
Humidity test	Temperature : 85 ± 2 °C Relative humidity : 85% Duration : 96 hours	MIL-STD 202G method 103
Dry heat (Aging test)	Temperature : 125 ± 2 °C Duration : 168 hours	MIL-STD 202G method 108A
Cold resistance (Low Temp Storage)	Temperature : -40 ± 2 °C Duration : 96 hours	IEC 60068-2-1



CAUTION: Electrostatic Sensitive Device. Observe precautions for handling.

NOTES:

1. The design, manufacturing process, and specifications of this device are subject to change.
2. US or International patents may apply.
3. RoHS compliant from the first date of manufacture.