

XO9012G

32.768000 KHz
XO

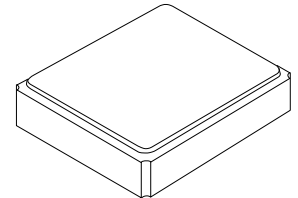

SM2520-4

Features:

- Surface Mount Seam Weld Package
- Excellent Reliability Performance
- Good Frequency Perturbation and Stability over temperature
- Moisture Sensitivity Level: 1

Application:

- 3.3 V Supply Voltage CMOS Output
- Option-able stand-by function for output .

Electrical Characteristics:

XO9012G	Specifications
Nominal Frequency, Fo	32.768000 KHz
Storage Temperature Range	-55°C to +125°C
Operating Temperature Range	-40°C to +85°C
Power Supply Voltage, Vcc	3.3 V +/- 10%
Load	15pF
“0” Level “1” Level	0.33 V max 2.97 V min
Power Supply Current, Icc	0.2 mA max
Frequency Accuracy ¹	+/-25 ppm max
Duty Cycle	40% ~ 60%
Rise Time (10% -> 90% of final RF level in Vp-p) Fall Time (90% -> 10% of final RF level in Vp-p)	30 nsec max. 30 nsec max
Enable/Disable Function	PIN 1: High or Open, PIN 3:Enable PIN 1: Low, PIN 3:Disable

#Note 1: Frequency accuracy includes 25C tolerance, operating temperature range -40 to 85 deg C, aging and voltage or load change

Mechanical Dimensions: (Unit: mm)

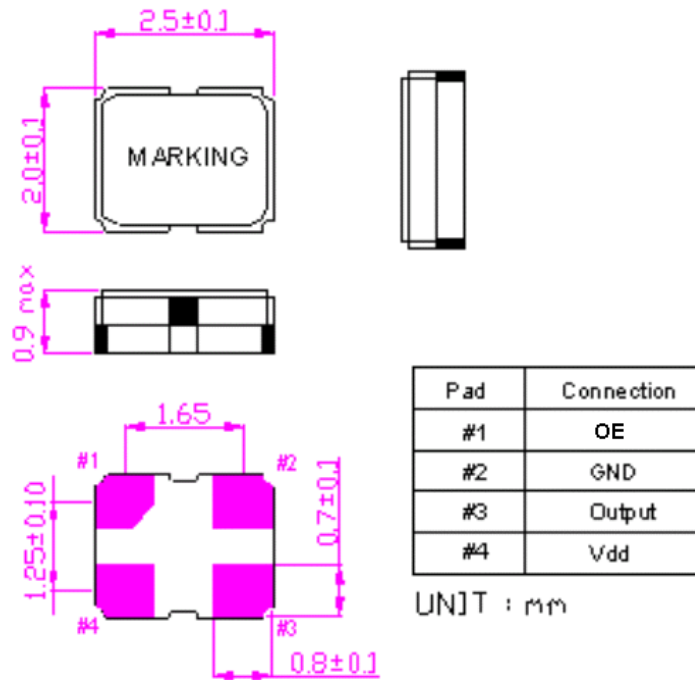

Test Circuit:

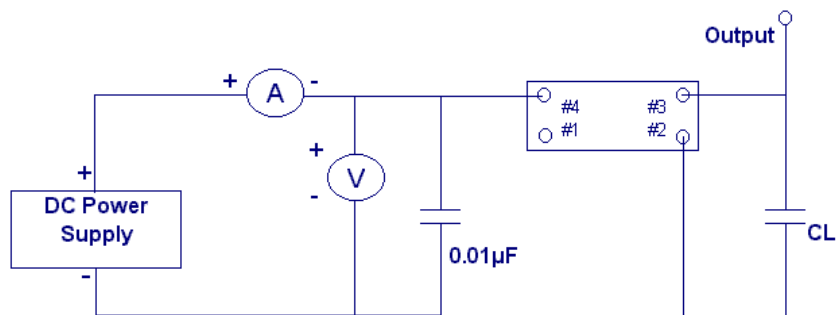

Output Waveform :

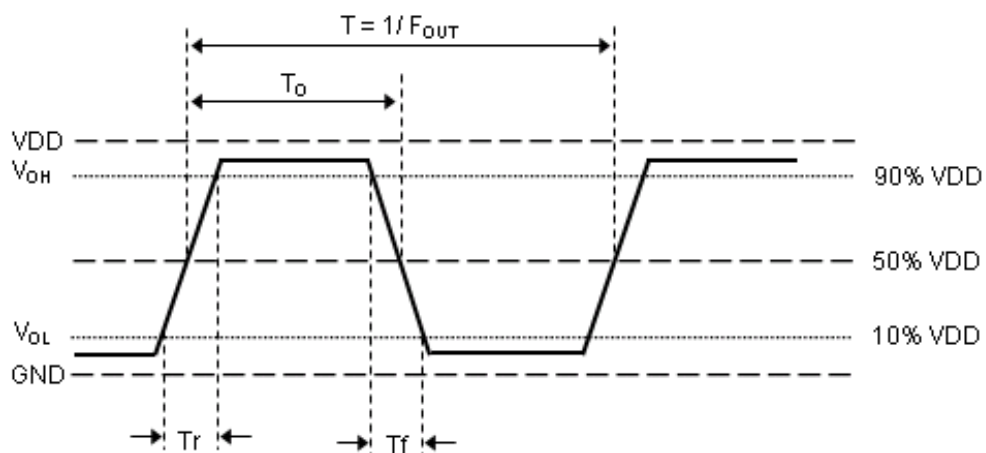

Marking:

Line 1: Frequency (32.7K)

Line 2: Date Code + Product Code (□X Internal tracking code, could be a~z and A~Z, □ : Can Track Year , (Under line With Even Year and Odd Year for Nothing)

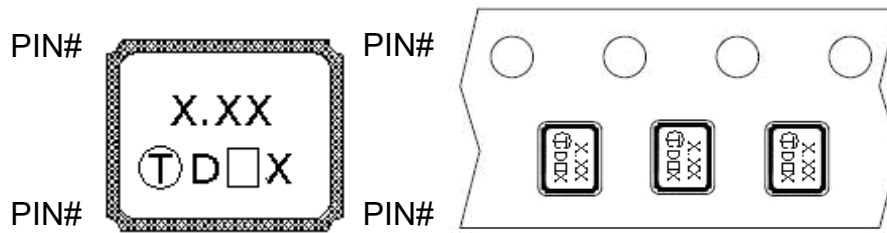

The inner vision of PIN#1, PIN#4 side is XTAL blank mounting pad.

Date Code Table

WK01	WK02	WK03	WK04	WK05	WK06	WK07	WK08	WK09	WK10	WK11	WK12	WK13
A	B	C	D	E	F	G	H	I	J	K	L	M
WK14	WK15	WK16	WK17	WK18	WK19	WK20	WK21	WK22	WK23	WK24	WK25	WK26
N	O	P	Q	R	S	T	U	V	W	X	Y	Z
WK27	WK28	WK29	WK30	WK31	WK32	WK33	WK34	WK35	WK36	WK37	WK38	WK39
a	b	c	d	e	f	g	h	i	j	k	l	m
WK40	WK41	WK42	WK43	WK44	WK45	WK46	WK47	WK48	WK49	WK50	WK51	WK52
n	o	p	q	r	s	t	u	v	w	x	y	z

Product Code Table: (Under line With Even Year and Odd Year for Nothing)

Year						Product Code
2013	2015	2017	2019	2021	2023	□
2014	2016	2018	2020	2022	2024	□

Reel Dimensions (mm):

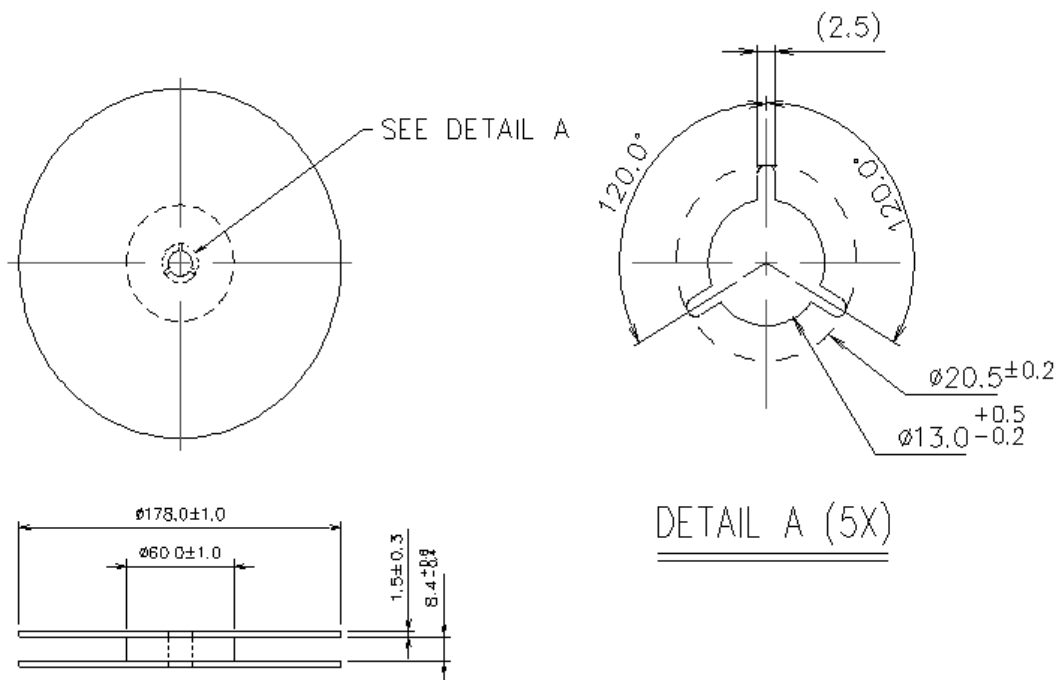

Tape Dimensions (mm):

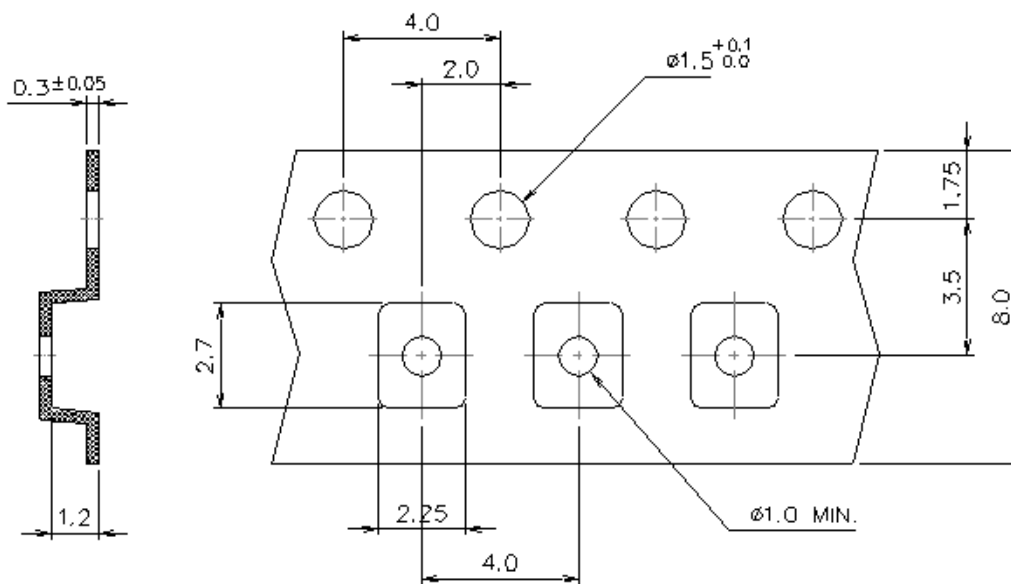

[NOTE]:

1. Unless otherwise specified tolerance on dimension ± 0.1 mm.
2. Material: conductive polystyrene with color black.
3. 10 pitch cumulative tolerance ± 0.2 mm.

Packing Quantity/Packing:

3K pcs maximum per reel

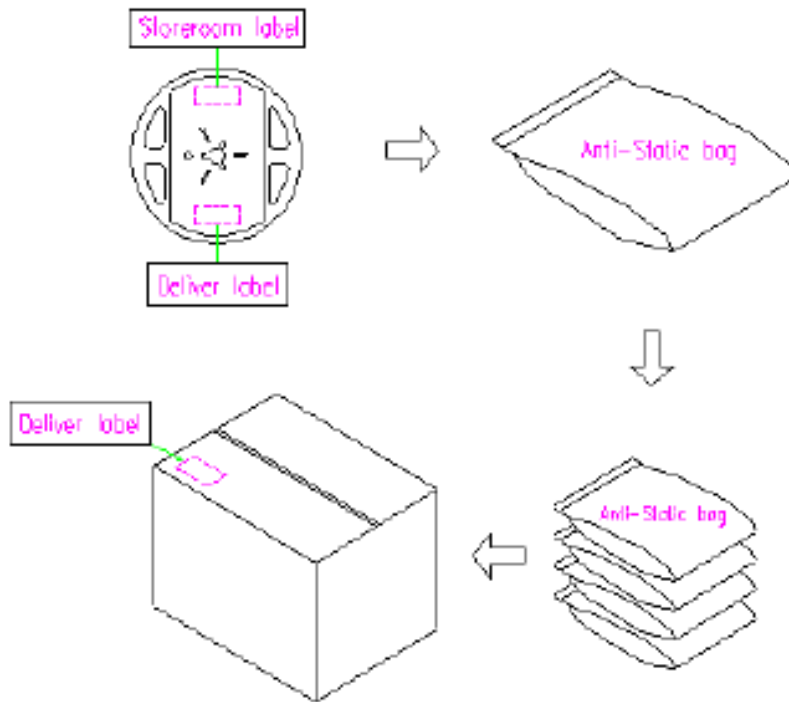

Reflow Profile:

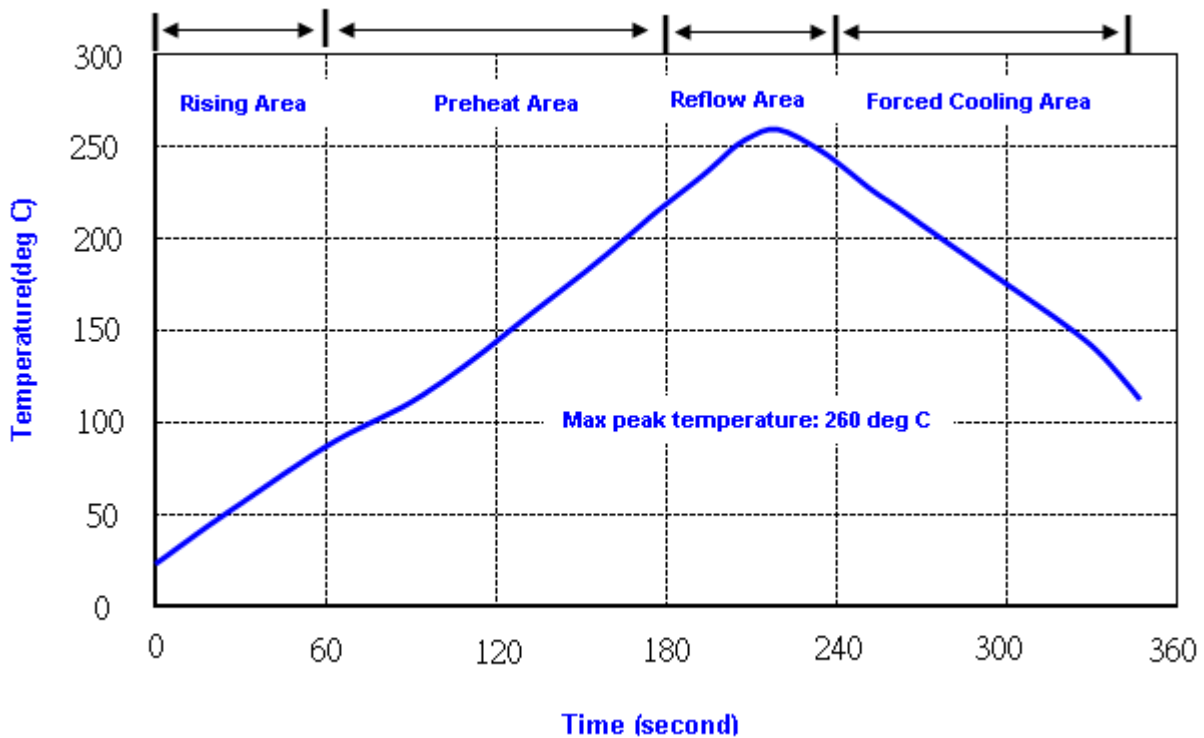

Note: 1. Max peak temperature: 260+/-5 deg C; Time: 10+/-2 sec
2. Temperature: 217+/-5 deg C; Time: 90~100 sec

Reliability Specifications

Test name	Test process / method	Reference standard
Mechanical characteristics		
resistance to Soldering heat (IR reflow)	Temp./ Duration : 265°C /10sec ×2 times Total time : 4min.(IR-reflow)	EIAJED-4701 -300(301)M(II)
Vibration	Total peak amplitude : 1.5mm Vibration frequency : 10 to 2000 Hz Sweep period : 20 minute Vibration directions : 3 mutually perpendicular Duration : 2 hr / direc.	MIL-STD 202G method 204
Mechanical Shock	directions : 3 impacts per axis Acceleration : 3000g's, +20/-0 % Duration : 0.3 ms (total 18 shocks) Waveform : Half-sine	MIL-STD 202G method 213
Solderability	Solder Temperature:265±5°C Duration time: 5±0.5 seconds.	J-STD-002
Environmental characteristics		
Thermal Shock	Heat cycle conditions -40 °C (30min) ↔ 85 °C (30min) * cycle time : 10 times	MIL-STD 883G method 1010.8
Humidity test	Temperature : 85 ± 2 °C Relative humidity : 85% Duration : 96 hours	MIL-STD 202G method 103
Dry heat (Aging test)	Temperature : 125 ± 2 °C Duration : 168 hours	MIL-STD 202G method 108A
Cold resistance (Low Temp Storage)	Temperature : -40 ± 2 °C Duration : 96 hours	IEC 60068-2-1



CAUTION: Electrostatic Sensitive Device. Observe precautions for handling.

1. The design, manufacturing process, and specifications of this device are subject to change.
2. US or International patents may apply.
3. RoHS compliant from the first date of manufacture.